



Bobcat®

Operation & Maintenance Manual



E26

Compact Excavator

S/N B4S911001 & Above



OPERATOR SAFETY WARNING



WARNING

Operator must have instructions before operating the machine. Untrained operators can cause injury or death.

W-2001-0502



Safety Alert Symbol: This symbol with a warning statement, means: "Warning, be alert! Your safety is involved!" Carefully read the message that follows.

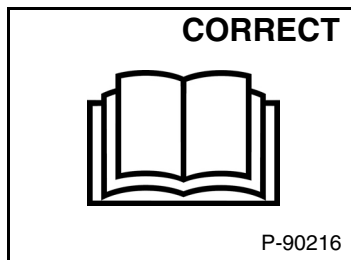

! Never operate without instructions.

! Read machine signs, and Operation & Maintenance Manual, and Operator's Handbook.

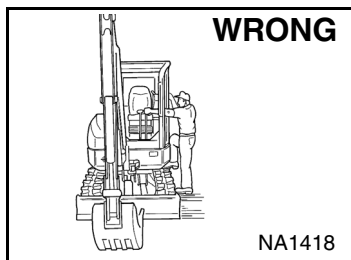

! Do not grasp control handles when entering cab / canopy.

! Be sure controls are in neutral before starting.

! Sound horn and check behind machine before starting.

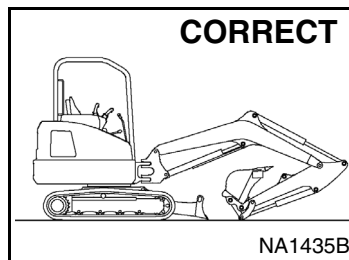

! Never operate without approved cab / canopy.

! Never modify equipment.

! Never use attachments not approved by Bobcat Company.

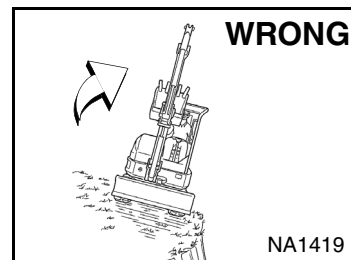

! Avoid steep areas or banks that could break away.

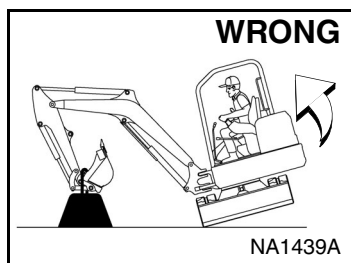

! Use caution to avoid tipping - do not swing heavy load over side of track.

! Operate on flat, level ground.

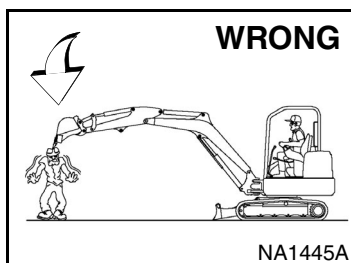

! Keep bystanders out of maximum reach area.

! Do not travel or turn with bucket extended.

! Never carry riders.

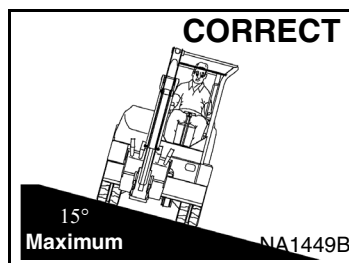

! Never exceed a 15° slope to the side.

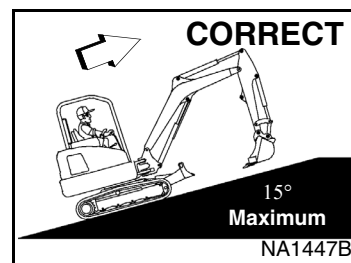

! Never travel up a slope that exceeds 15°.

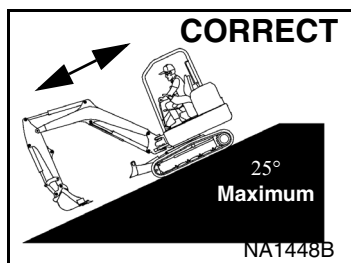

! Never exceed 25° when going down or backing up a slope.

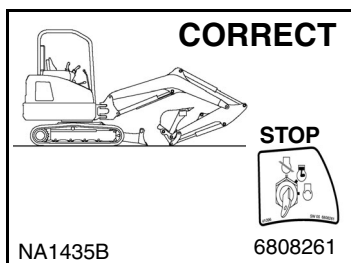

! To leave excavator, lower the work equipment and the blade to the ground.

! Stop the engine.

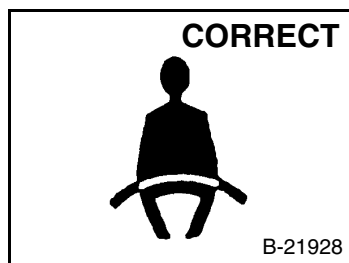

! Fasten seat belt securely.

! Operate controls only from operator's seat.

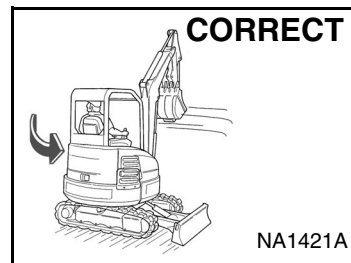

! Look in the direction of rotation and make sure no bystanders are in the work area.

SAFETY EQUIPMENT

The Bobcat® excavator must be equipped with safety items necessary for each job. Ask your Bobcat dealer for information on the availability and safe use of attachments and accessories.

1. SEAT BELT: Check belt fasteners and check for damaged webbing or buckle.
2. OPERATOR CAB / CANOPY (ROPS and TOPS): Check condition and mounting hardware.
3. OPERATOR'S HANDBOOK: Must be in the cab / canopy.
4. LEFT HAND CONSOLE: When raised must deactivate the travel and hydraulic functions.
5. SAFETY SIGNS (DECALS): Replace if damaged.
6. GRAB HANDLES: Replace if damaged.
7. INTEGRATED SLEW LOCK BRAKE.
8. SAFETY TREAD.: Replace if damaged.

OSW66-0117

CONTENTS

CONTENTS	1
FOREWORD	2
SAFETY AND TRAINING RESOURCES	8
OPERATING INSTRUCTIONS	21
PREVENTIVE MAINTENANCE	104
SYSTEM SETUP AND ANALYSIS	152
SPECIFICATIONS	169
WARRANTY	179
ALPHABETICAL INDEX	181

REFERENCE INFORMATION

Write the correct information for YOUR Bobcat excavator in the spaces below. Always use these numbers when referring to your Bobcat excavator.

Excavator Serial
Number

Engine Serial Number

NOTES:

YOUR BOBCAT DEALER:

ADDRESS:

PHONE:

Bobcat Company
250 E. Beaton Drive
West Fargo, ND 58078
UNITED STATES OF AMERICA

FOREWORD

This Operation & Maintenance Manual was written to give the owner / operator instructions on the safe operation and maintenance of the Bobcat excavator. READ AND UNDERSTAND THIS OPERATION & MAINTENANCE MANUAL BEFORE OPERATING YOUR BOBCAT EXCAVATOR. If you have any questions, see your Bobcat dealer. This manual may illustrate options and accessories not installed on your excavator.

BOBCAT COMPANY IS ISO 9001 CERTIFIED	3
REGULAR MAINTENANCE ITEMS	3
SERIAL NUMBER LOCATION	4
Excavator Serial Number	4
Engine Serial Number	4
DELIVERY REPORT	4
EXCAVATOR IDENTIFICATION	5
FEATURES, ACCESSORIES, AND ATTACHMENTS	6
Standard Items	6
Options And Accessories	6
Attachments	6
Buckets Available	6
Falling-Object Protective Structure (FOPS) (Canopy Model)	7
Falling-Object Protective Structure (FOPS) (Cab Model)	7
Front Guard Kit	7
Front Guard Kit Inspection And Maintenance	7

BOBCAT COMPANY IS ISO 9001 CERTIFIED











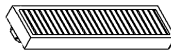

ISO 9001 is an international standard that specifies requirements for a quality management system that controls the processes and procedures which we use to design, develop, manufacture, and distribute Bobcat products.

British Standards Institute (BSI) is the Certified Registrar Bobcat Company chose to assess the company’s compliance with the ISO 9001 at Bobcat’s manufacturing facilities in Gwinner, North Dakota (U.S.A.), Pontchâteau (France), and the Bobcat corporate offices (Gwinner, Bismarck, and West Fargo) in North Dakota. TÜV Rheinland is the Certified Registrar Bobcat Company chose to assess the company’s compliance with the ISO 9001 at Bobcat’s manufacturing facility in Dobris (Czech Republic). Only certified assessors, like BSI and TÜV Rheinland, can grant registrations.

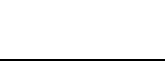
ISO 9001 means that as a company we say what we do and do what we say. In other words, we have established procedures and policies, and we provide evidence that the procedures and policies are followed.

REGULAR MAINTENANCE ITEMS

 <p>ENGINE OIL FILTER 6657635</p>	 <p>HVAC AIR FILTER (IF EQUIPPED) Fresh Air 7176099 Recirculation 7222791</p>
 <p>FUEL FILTER 6667352</p>	 <p>BATTERY 7304126</p>
  <p>AIR FILTER, Outer 6673752</p> <p>AIR FILTER, Inner 6673753</p>	  <p>PRIMARY HYDRAULIC FILTER 6661248 CASE DRAIN HYDRAULIC FILTER 7009365</p>
 <p>HYDRAULIC FILL / BREATHER CAP 7024201</p>	 <p>RADIATOR CAP 7348260</p>
 <p>ANTI-FREEZE (See Coolant Types on Page 127.)</p> <p>6987793 - PG Premixed 6987804 - EG Premixed</p>	 <p>FLUID, Hydraulic / Hydrostatic</p> <p>6903117 - (2.5 U.S. gal) 6903118 - (5 U.S. gal) 6903119 - (55 U.S. gal)</p>
<p>ENGINE OIL</p> <p>7023080 SAE 15W-40 – qt 7023076 SAE 10W-30 – qt 6989147 Synthetic SAE 5W-40 – qt</p> <p>7023082 SAE 15W-40 – 2.5 U.S. gal 7023078 SAE 10W-30 – 2.5 U.S. gal</p>	<p>GEAR LUBE 6903121 - HD 80W-90 (12 qt)</p> <p>ENGINE OIL</p> <p>7023081 SAE 15W-40 – U.S. gal 7023077 SAE 10W-30 – U.S. gal 6989148 Synthetic SAE 5W-40 – U.S. gal</p>

NOTE: Always verify Part Numbers with your Bobcat dealer.

SERIAL NUMBER LOCATION

Always use the serial number of the excavator when requesting service information or when ordering parts. Earlier or later models (identification made by serial number) may use different parts, or it may be necessary to use a different procedure in doing a specific service operation

Excavator Serial Number

Figure 1

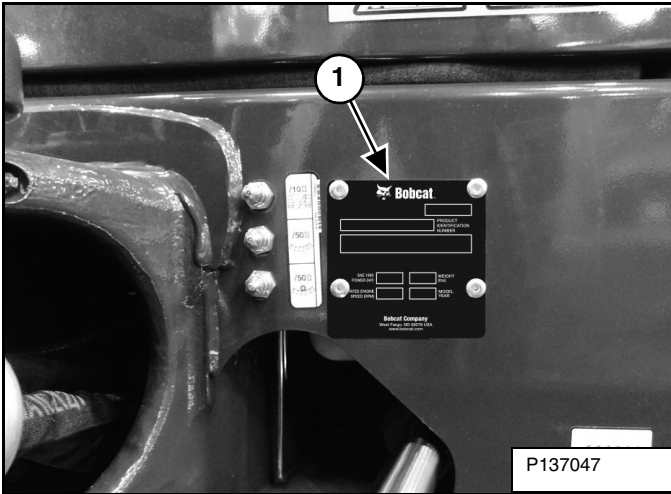

The excavator serial number plate (Item 1) [Figure 1] is located on the frame of the machine in the location shown.

Engine Serial Number

Figure 2

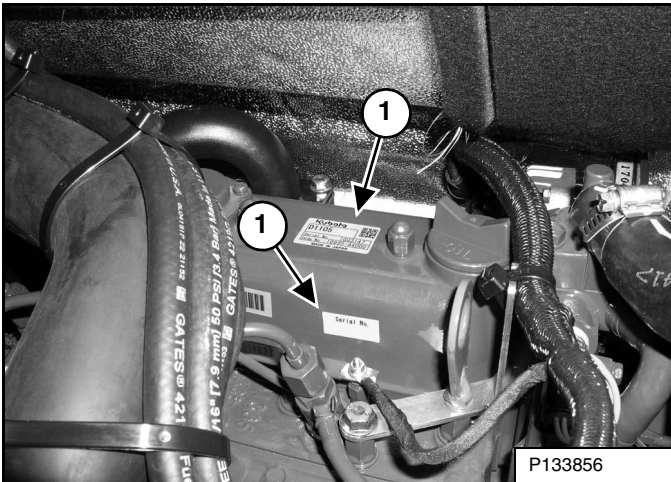

The engine serial number is located on the top cover (two locations) (Item 1) [Figure 2].

DELIVERY REPORT

Figure 3

The delivery report [Figure 3] contains a list of items that must be explained or shown to the owner or operator by the dealer when the Bobcat excavator is delivered.

The delivery report must be reviewed and signed by the owner or operator and the dealer.

EXCAVATOR IDENTIFICATION

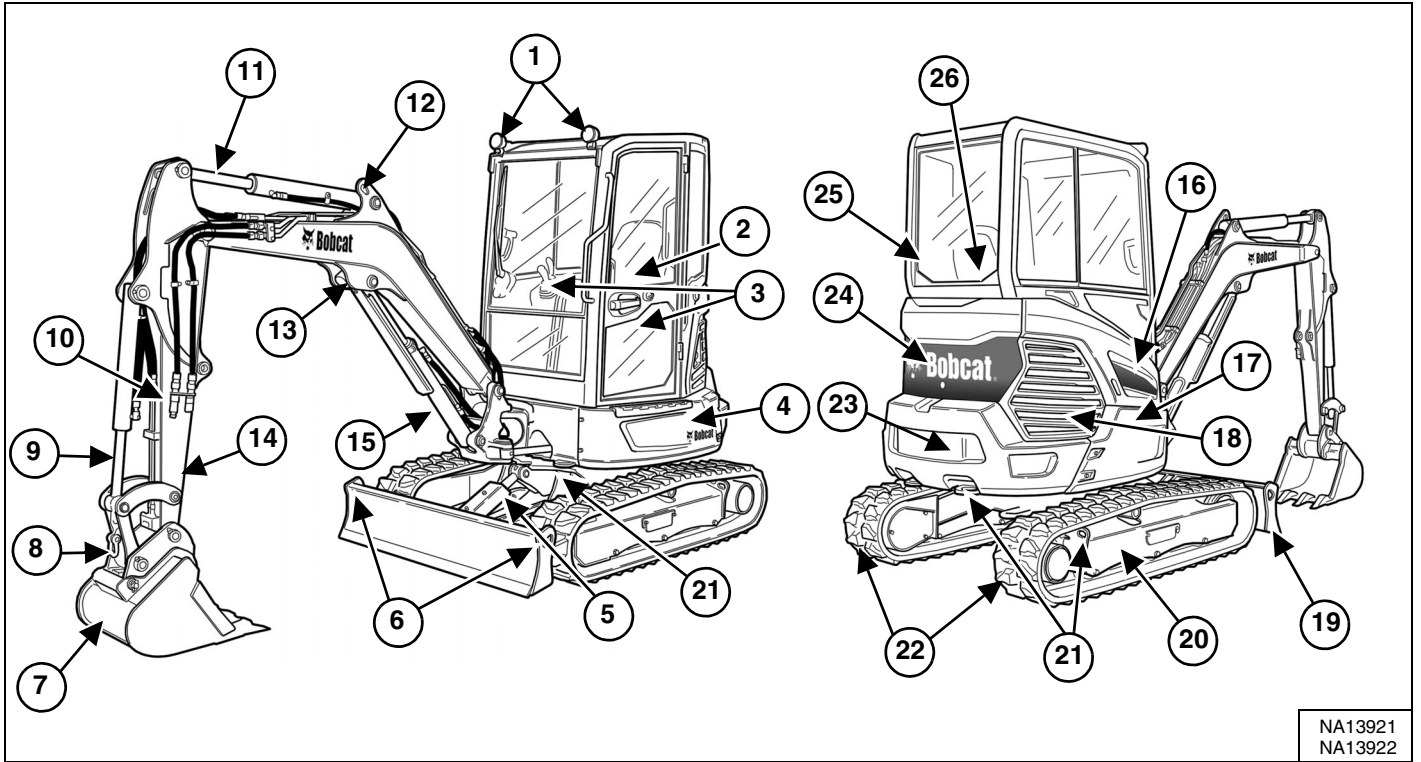

NA13921
NA13922

ITEM	DESCRIPTION	ITEM	DESCRIPTION
1	LIGHTS (IF EQUIPPED)	16	RIGHT SIDE COVER
2	OPERATOR'S SEAT WITH SEAT BELT	17	RIGHT SIDE PANEL
3	JOYSTICKS	18	REAR SIDE COVER
4	UPPERSTRUCTURE	19	BLADE
5	BLADE CYLINDER	20	TRACK FRAME
6	TIE-DOWNS / LIFT POINTS	21	TIE-DOWNS (BOTH SIDES)
7	BUCKET [1]	22	TRACKS [3]
8	ATTACHMENT QUICK COUPLER (IF EQUIPPED) [2]	23	COUNTERWEIGHT
9	BUCKET CYLINDER	24	TAILGATE
10	AUXILIARY HYDRAULIC COUPLERS (IF EQUIPPED)	25	CANOPY / CAB (ROPS / TOPS / FOPS) [4]
11	ARM CYLINDER	26	OPERATOR'S HANDBOOK
12	LIFT POINT		
13	BOOM		
14	ARM		
15	BOOM CYLINDER		

[1] BUCKET - Several different buckets and other attachments are available from the Bobcat excavator.

[2] ATTACHMENT COUPLER - Optional attachment couplers are available.

[3] TRACKS - Optional tracks are available.

[4] ROPS, TOPS - (Roll-Over Protective Structure / Tip-Over Protective Structure) per ISO 12117-2 and ISO 12117. FOPS (Falling Object Protective Structure / Top Guard) per ISO 10262 - Level 1.

FEATURES, ACCESSORIES, AND ATTACHMENTS

Standard Items

Model E26 Bobcat excavators are equipped with the following standard items:

- 1550 mm (61.0) Dozer Blade
- Canopy with ROPS / TOPS / FOPS Approval
- 300 mm (11.8 in) Rubber Tracks
- Standard Instrument Panel
- Two-Speed Travel
- Long Arm
- Auto Shift Drive Motors
- Engine Speed Control Dial With Auto Idle Feature
- Hydraulic and Travel Control Lockouts
- Boom Mounted Work Light
- Engine and Hydraulic System Monitor with Shut Down
- Horn
- Hydraulic Joystick Controls
- Auxiliary Hydraulics and Quick Couplers
- Basic Seat
- Retractable Seat Belt
- Advanced Diagnostics
- Counterweight
- Fuel Filter with Sediment Bowl
- X-Change™

Options And Accessories

Below is a list of some equipment available from your Bobcat excavator dealer as Dealer and/or Factory Installed Accessories and Factory Installed Options. See your Bobcat dealer for other available options, accessories and attachments.

- Enclosed Cab With Heater and A/C
- Travel Motion Alarm
- Deluxe Instrument Panel with Keyless Start
- Primary and Secondary Auxiliary Hydraulics
- Canopy / Cab Mounted Lights
- Front Guard Kit (upper and lower guards)
- Load Holding Valve - Boom
- Load Holding Valve - Arm
- Rotating Beacon Light
- Strobe Light
- Side Mirror
- Radio (FM / AM / DAB / Phone Ready)
- Auxiliary Hydraulic Lines Mounted On Arm*
- Vinyl or Cloth Suspension Seat
- Block Heater
- Muffler Purifier

****This option may influence the availability of other attachments. See your Bobcat dealer for information about approved attachments for auxiliary hydraulic lines mounted on the arm.***

Attachments

These and other attachments are approved for use on this model Bobcat excavator. Do not use unapproved attachments. Attachments not manufactured by Bobcat may not be approved.

The versatile Bobcat excavator quickly turns into a multi-job machine with a variety of attachments.

See your Bobcat dealer for information about approved attachments and attachment Operation & Maintenance Manuals.

- Auger
- Breaker
- Grading Blade
- Hydra-Tilt™ swing accessory
- Hydraulic Clamp
- Packer Wheel
- Power-Tilt® swing accessory
- Ripper
- Three-Tine Grapple

Buckets Available

Increase the versatility of your Bobcat Excavator with a variety of bucket sizes.

Many bucket styles, widths and different capacities are available for a variety of different applications. They include Trenching, Digging, Grading, to name a few. See your Bobcat dealer for the correct bucket for your Bobcat excavator and application.

Specifications subject to change without notice and standard items may vary.

FEATURES, ACCESSORIES AND ATTACHMENTS (CONT'D)

Falling-Object Protective Structure (FOPS) (Canopy Model)

Figure 4

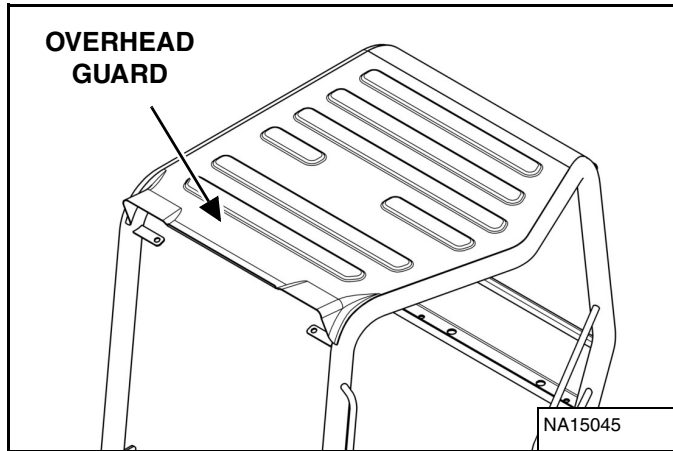

The excavator canopy is qualified as a Falling Object Protective Structure (FOPS) that meets the top guard requirements in ISO 10262 - Level 1 [Figure 4].

Falling-Object Protective Structure (FOPS) (Cab Model)

Figure 5

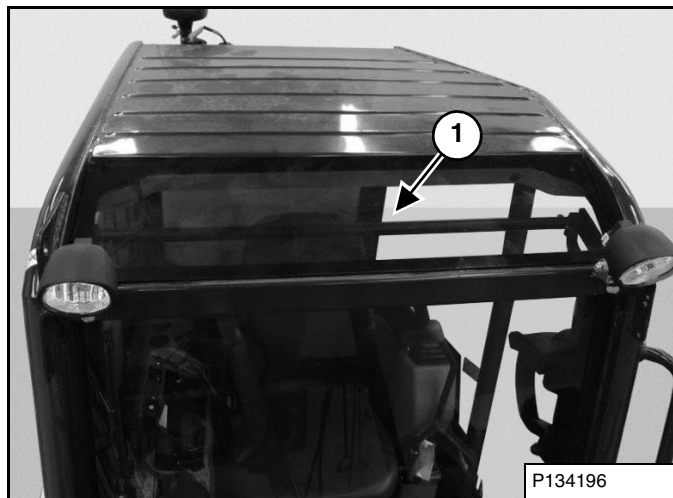

The top window (Item 1) [Figure 5] on cab models is a Falling Object Protective Structure (FOPS) that meets the top guard requirements in ISO 10262.

Front Guard Kit

Figure 6

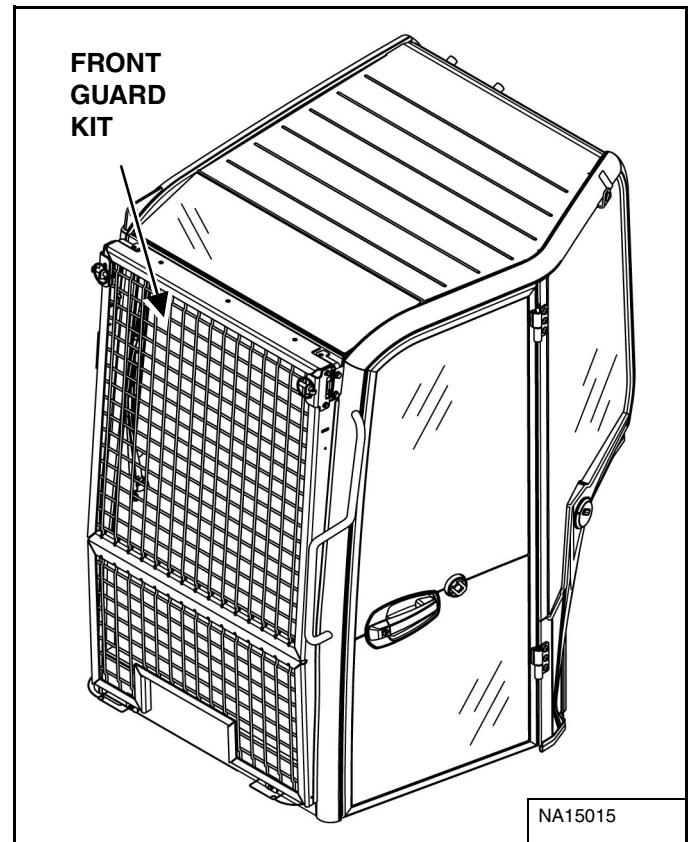

Available for applications that require protection from objects entering the front of the excavator.

The excavator must have the Front Guard Kit [Figure 6] installed to meet the front guard requirements in FOGS ISO 10262 - Level 1.

Kit includes an upper and lower screen guard.

See your Bobcat Dealer for more information.

Front Guard Kit Inspection And Maintenance

The Front Guard Kit must be regularly inspected and maintained. Inspect the screen for damage. Replace parts as necessary.

SAFETY AND TRAINING RESOURCES

SAFETY INSTRUCTIONS	9
Before Operation	9
Safe Operation Is The Operator's Responsibility	10
Safe Operation Needs A Qualified Operator	10
Avoid Silica Dust	11
FIRE PREVENTION	11
Maintenance	11
Operation	11
Electrical	11
Hydraulic System	12
Fueling	12
Starting	12
Spark Arrester Exhaust System	12
Welding And Grinding	12
Fire Extinguishers	12
PUBLICATIONS AND TRAINING RESOURCES	13
MACHINE SIGNS (DECALS)	14
Pictorial Only Safety Signs	16

SAFETY INSTRUCTIONS

Before Operation

Carefully follow the operating and maintenance instructions in this manual.

The Bobcat excavator is highly maneuverable and compact. It is rugged and useful under a wide variety of conditions. This presents an operator with hazards associated with off highway, rough terrain applications, common with Bobcat excavator usage.

The Bobcat excavator has an internal combustion engine with resultant heat and exhaust. All exhaust gases can kill or cause illness so use the excavator with adequate ventilation.

The dealer explains the capabilities and restrictions of the Bobcat excavator and attachment for each application. The dealer demonstrates the safe operation according to Bobcat instructional materials, which are also available to operators. The dealer can also identify unsafe modifications or use of unapproved attachments. The attachments and buckets are designed for a Rated Lift Capacity. They are designed for secure fastening to the Bobcat excavator. The user must check with the dealer, or Bobcat literature, to determine safe loads of materials of specified densities for the machine - attachment combination.

The following publications and training materials provide information on the safe use and maintenance of the Bobcat machine and attachments:

- The Delivery Report is used to assure that complete instructions have been given to the new owner and that the machine and attachment is in safe operating condition.
- The Operation & Maintenance Manual delivered with the machine or attachment gives operating information as well as routine maintenance and service procedures. It is a part of the machine and can be stored in a container provided on the machine. Replacement Operation & Maintenance Manuals can be ordered from your Bobcat dealer.
- Machine signs (decals) instruct on the safe operation and care of your Bobcat machine or attachment. The signs and their locations are shown in the Operation & Maintenance Manual. Replacement signs are available from your Bobcat dealer.

- An Operator's Handbook is fastened to the operator cab of the excavator. It's brief instructions are convenient to the operator. The handbook is available from your dealer in an English edition or one of many other languages. See your Bobcat dealer for more information on translated versions.
- The AEM Safety Manual delivered with the machine gives general safety information.
- The Compact Excavator Operating Training Course is available through your Bobcat dealer. This course is intended to provide rules and practices of correct operation of the Bobcat excavator. The course is available in English and Spanish versions.
- Service Safety Training Courses are available from your Bobcat dealer. They provide information for safe and correct service procedures.
- See the PUBLICATIONS AND TRAINING RESOURCES Page in this manual or your Bobcat dealer for Service and Parts Manuals, printed materials, videos, or training courses available. Also check the Bobcat websites **Bobcat.com/training** or **Bobcat.com**.

The dealer and owner / operator review the recommended uses of the product when delivered. If the owner / operator will be using the machine for a different application(s) he or she must ask the dealer for recommendations on the new use.



Call Before You Dig
Dial 811 (USA Only)
1-888-258-0808 (USA & Canada)

When you call, you will be directed to a location in your state / province, or city for information about buried lines (telephone, cable TV, water, sewer, gas, etc.).

SAFETY INSTRUCTIONS (CONT'D)

Safe Operation Is The Operator's Responsibility



Operator must have instructions before operating the machine. Untrained operators can cause injury or death.

W-2001-0502



This notice identifies procedures which must be followed to avoid damage to the machine.

I-2019-0284



The signal word **DANGER** on the machine and in the manuals indicates a hazardous situation which, if not avoided, will result in death or serious injury.

D-1002-1107



The signal word **WARNING** on the machine and in the manuals indicates a potentially hazardous situation which, if not avoided, could result in death or serious injury.

W-2044-1107

The Bobcat excavator and attachment must be in good operating condition before use.

Check all of the items on the Bobcat Service Schedule Decal under the 8 – 10 hour column or as shown in the Operation & Maintenance Manual.

Safe Operation Needs A Qualified Operator

For an operator to be qualified, he or she must not use drugs or alcoholic drinks which impair alertness or coordination while working. An operator who is taking prescription drugs must get medical advice to determine if he or she can safely operate a machine.

A Qualified Operator Must Do The Following:

Understand the Written Instructions, Rules and Regulations

- The written instructions from Bobcat Company include the Delivery Report, Operation & Maintenance Manual, Operator's Handbook, Safety Manual and machine signs (decals).
- Check the rules and regulations at your location. The rules may include an employer's work safety requirements. Regulations may apply to local driving requirements or use of a Slow Moving Vehicle (SMV) emblem. Regulations may identify a hazard such as a utility line.

Have Training with Actual Operation

- Operator training must consist of a demonstration and verbal instruction. This training is given by your Bobcat dealer before the product is delivered.
- The new operator must start in an area without bystanders and use all the controls until he or she can operate the machine and attachment safely under all conditions of the work area. Always fasten seat belt before operating.
- Operator Training Courses are available from your Bobcat dealer in English and Spanish. They provide information for safe and efficient equipment operation. Safety videos are also available.
- Service Safety Training Courses are available from your Bobcat dealer. They provide information for safe and correct service procedures.

Know the Work Conditions

- Know the weight of the materials being handled. Avoid exceeding the Rated Lift Capacity of the machine. Material which is very dense will be heavier than the same volume of less dense material. Reduce the size of load if handling dense material.
- The operator must know any prohibited uses or work areas, for example, he or she needs to know about excessive slopes.
- Know the location of any underground lines. Call local utilities or the TOLL-FREE phone number found in the *Before Operation* section of this manual.
- Wear tight fitting clothing. Always wear safety glasses when doing maintenance or service. Safety glasses, respiratory equipment, hearing protection or Special Applications Kits are required for some work. See your Bobcat dealer about Bobcat safety equipment for your model.

SI EXC-1016

SAFETY INSTRUCTIONS (CONT'D)

Avoid Silica Dust

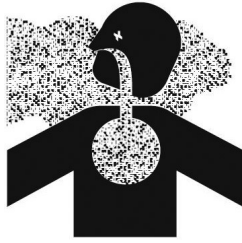

Cutting or drilling concrete containing sand or rock containing quartz may result in exposure to silica dust. Do not exceed Permissible Exposure Limits (PEL) to silica dust as determined by OSHA or other job site Rules and Regulations. Use a respirator, water spray or other means to control dust. Silica dust can cause lung disease and is known to the state of California to cause cancer.

FIRE PREVENTION



Maintenance

The machine and some attachments have components that are at high temperatures under normal operating conditions. The primary source of high temperatures is the engine and exhaust system. The electrical system, if damaged or incorrectly maintained, can be a source of arcs or sparks.

Flammable debris (leaves, straw, etc.) must be removed regularly. If flammable debris is allowed to accumulate, it can cause a fire hazard. Clean often to avoid this accumulation. Flammable debris in the engine compartment is a potential fire hazard.

The operator's area, engine compartment and engine cooling system must be inspected every day and cleaned if necessary to prevent fire hazards and overheating.

All fuels, most lubricants and some coolant mixtures are flammable. Flammable fluids that are leaking or spilled onto hot surfaces or onto electrical components can cause a fire.

Operation

Do not use the machine where exhaust, arcs, sparks or hot components can contact flammable material, explosive dust or gases.

Electrical



Check all electrical wiring and connections for damage. Keep the battery terminals clean and tight. Repair or replace any damaged part or wires that are loose or frayed.

Battery gas can explode and cause serious injury. Use the procedure in the Operation & Maintenance Manual for connecting the battery and for jump starting. Do not jump start or charge a frozen or damaged battery. Keep any open flames or sparks away from batteries. Do not smoke in battery charging area.

SI EXC-1016

FIRE PREVENTION (CONT'D)

Hydraulic System

Check hydraulic tubes, hoses, and fittings for damage and leakage. Never use open flame or bare skin to check for leaks. Hydraulic tubes and hoses must be properly routed and have adequate support and secure clamps. Tighten or replace any parts that show leakage.

Always clean fluid spills. Do not use gasoline or diesel fuel for cleaning parts. Use commercial nonflammable solvents.

Fueling



Stop the engine and let it cool before adding fuel. No smoking! Do not refuel a machine near open flames or sparks. Fill the fuel tank outdoors.

Ultra Low Sulfur Diesel (ULSD) poses a greater static ignition hazard than earlier diesel formulations with higher Sulfur content. Avoid death or serious injury from fire or explosion. Consult with your fuel or fuel system supplier to ensure the delivery system is in compliance with fueling standards for proper grounding and bonding practices.

Starting

Do not use ether or starting fluids on any engine that has glow plugs or air intake heater. These starting aids can cause explosion and injure you or bystanders.

Use the procedure in the Operation & Maintenance Manual for connecting the battery and for jump starting.

Spark Arrester Exhaust System

The spark arrester exhaust system is designed to control the emission of hot particles from the engine and exhaust system, but the muffler and the exhaust gases are still hot.

Check the spark arrester exhaust system regularly to make sure it is maintained and working properly. Use the procedure in the Operation & Maintenance Manual for cleaning the spark arrester muffler (if equipped).

Welding And Grinding

Always clean the machine and attachment, disconnect the battery, and disconnect the wiring from the Bobcat controllers before welding. Cover rubber hoses, battery, and all other flammable parts. Keep a fire extinguisher near the machine when welding.

Have good ventilation when grinding or welding painted parts. Wear dust mask when grinding painted parts. Toxic dust or gas can be produced.

Dust generated from repairing nonmetallic parts such as hoods, fenders or covers can be flammable or explosive. Repair such components in a well ventilated area away from open flames or sparks.

Fire Extinguishers

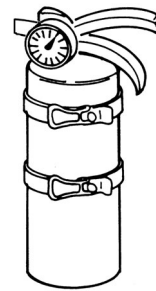

Know where fire extinguishers and first aid kits are located and how to use them. Inspect the fire extinguisher and service the fire extinguisher regularly. Obey the recommendations on the instructions plate.

PUBLICATIONS AND TRAINING RESOURCES

The following publications are also available for your Bobcat excavator. You can order them from your Bobcat dealer.

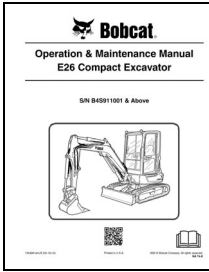

OPERATION & MAINTENANCE MANUAL

7354961

Complete instructions on the correct operation and the routine maintenance of your Bobcat excavator.



SAFETY MANUAL

6901951 (English and Spanish)

Gives basic safety procedures and warnings for your Bobcat excavator.

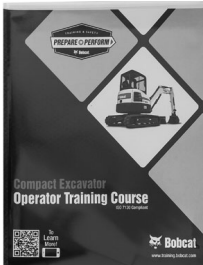

COMPACT EXCAVATOR OPERATOR TRAINING COURSE

7249283 (English)
7249286 (Spanish)

Introduces operator to step-by-step basics of excavator operation.

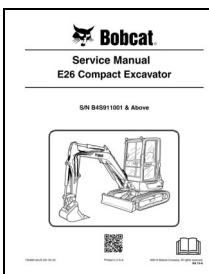

SERVICE MANUAL

7354962

Complete maintenance instructions for your Bobcat excavator.

For the latest information on Bobcat products and the Bobcat Company, visit our Web site at Bobcat.com/training or Bobcat.com.

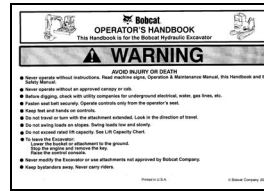

OPERATOR'S HANDBOOK

7311306

Gives basic operation instructions and safety warnings.



OPERATOR SAFETY DVD

6904762 (English and Spanish)

DVD gives basic safety instructions for many Bobcat products including excavators.



EXCAVATOR SERVICE SAFETY TRAINING COURSE

6900916

Introduces service technicians to step-by-step basics of proper and safe excavator maintenance and servicing procedures.



EXCAVATOR SAFETY VIDEO

(Mobile device with quick response code application required)

Scan the code above to watch the excavator safety video or view at Bobcat.com/training.

MACHINE SIGNS (DECALS)

Follow the instructions on all the Machine Signs (Decals) that are on the excavator. Replace any damaged machine signs and be sure they are in the correct locations. Machine signs are available from your Bobcat excavator dealer.

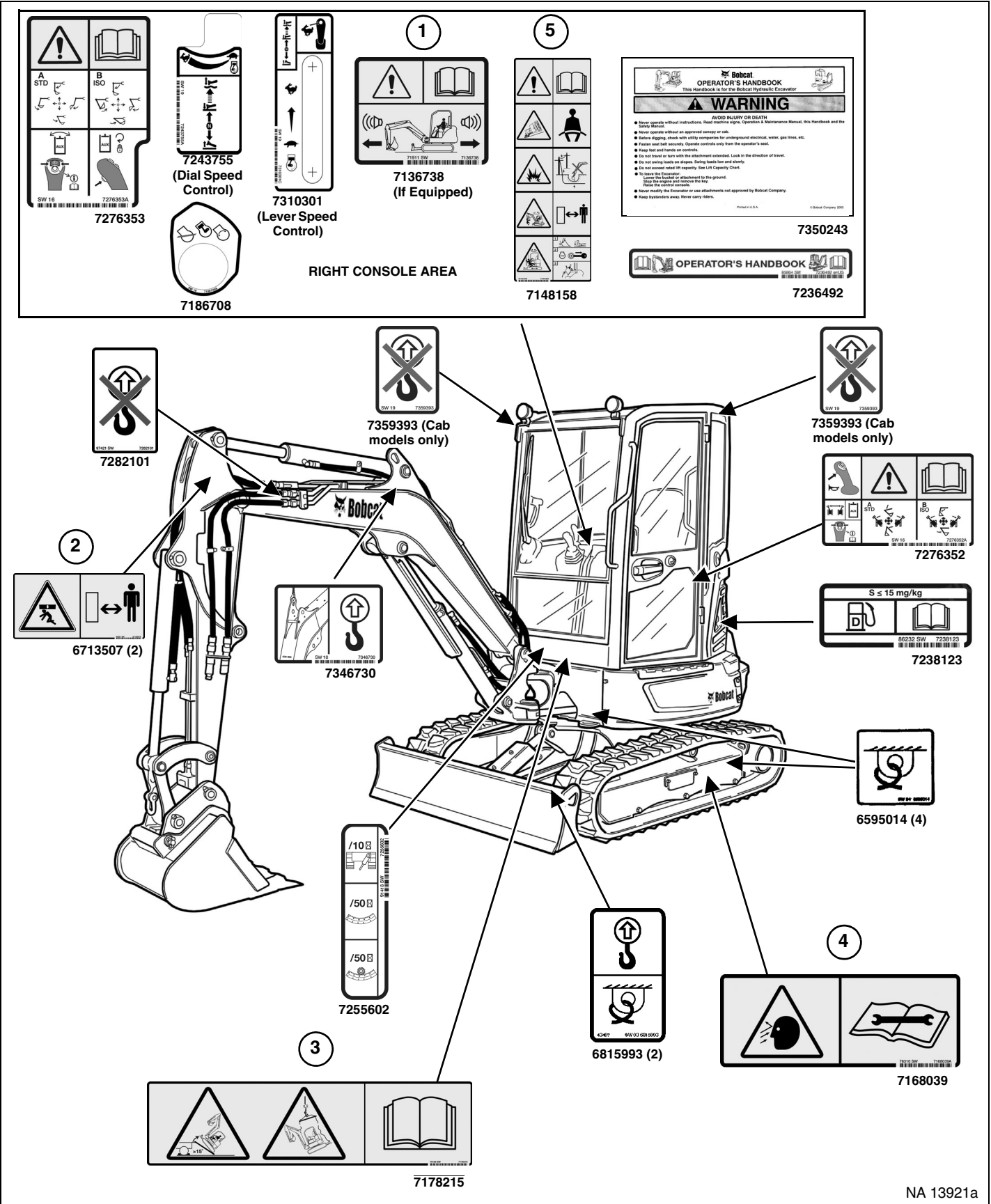

NA 13921a

MACHINE SIGNS (DECALS) (CONT'D)

Pictorial Only Safety Signs

Safety signs are used to alert the equipment operator or maintenance person to hazards that may be encountered in the use and maintenance of the equipment. The location and description of the safety signs are detailed in this section. Please become familiarized with all safety signs installed on the excavator.

Vertical Configuration

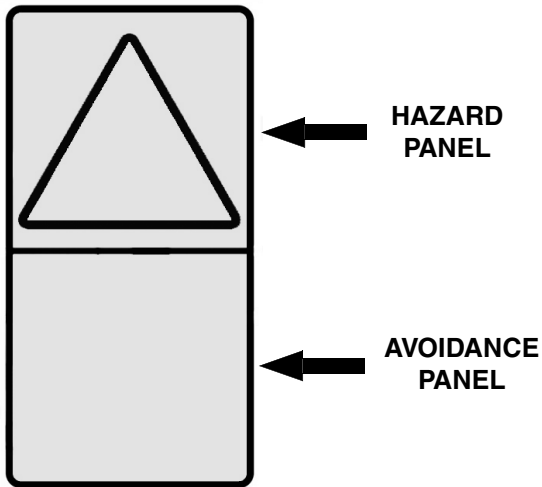

Horizontal Configuration

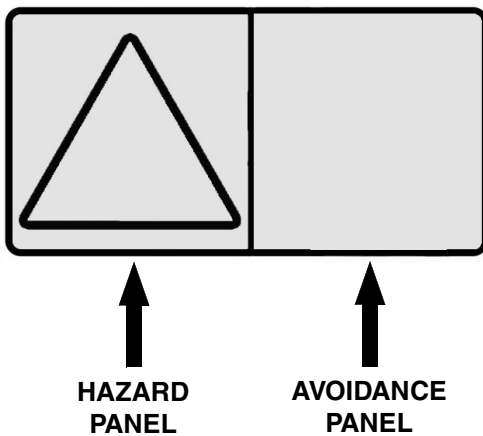

The format consists of the hazard panel(s) and the avoidance panel(s):

Hazard panels depict a potential hazard enclosed in a safety alert triangle.

Avoidance panels depict actions required to avoid the hazards.

A safety sign may contain more than one hazard panel and more than one avoidance panel.

NOTE: See the numbered MACHINE SIGNS (DECALS) on Page 14 and Machine Signs (Decals) (Cont'd) on Page 15 for the machine location of each corresponding numbered pictorial only decals as shown below.

1. Motion Alarm (7136738)

This safety sign is located on the ceiling of canopy models and on the right window of cab models.

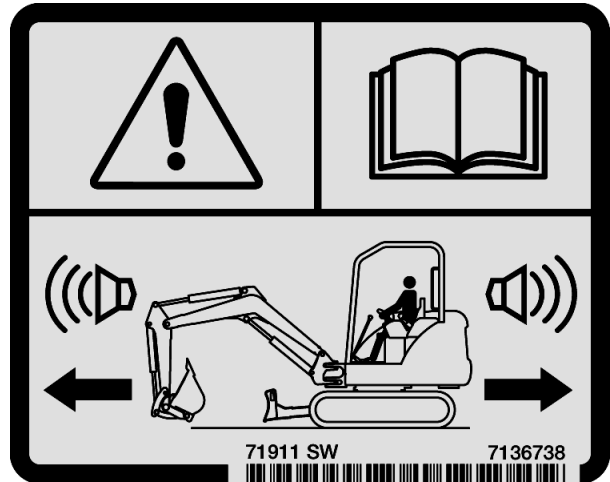

**This machine is equipped with a motion alarm.
ALARM MUST SOUND!
when operating forward or backward.**

Failure to maintain a clear view in the direction of travel could result in serious injury or death.

The operator is responsible for the safe operation of this machine.

W-2786-0309

MACHINE SIGNS (DECALS) (CONT'D)

Pictorial Only Safety Signs (Cont'd)

2. Crush Hazard (6713507)

This safety sign is located on both sides of the boom.

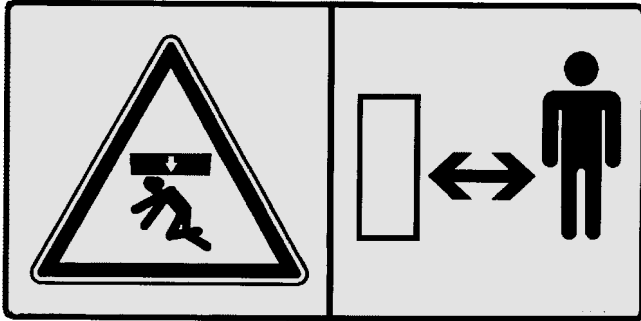

Keep away from the operating machine to avoid serious injury or death.

W-2520-0106

3. Transporting And Lifting (7178215)

This safety sign is located on the front of the cab.

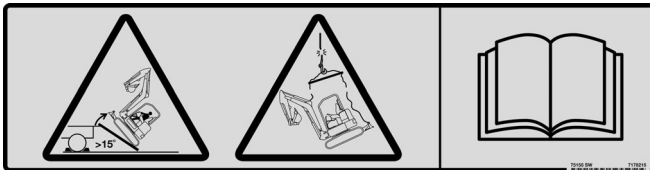

Improper loading, transporting and lifting procedures can cause serious injury or death. Read and understand the Operation & Maintenance Manual prior to transporting or lifting the machine.

W-2517-0110

4. Thrown Or Flying Objects (7168039)

This safety sign is located on the outside of both tracks.

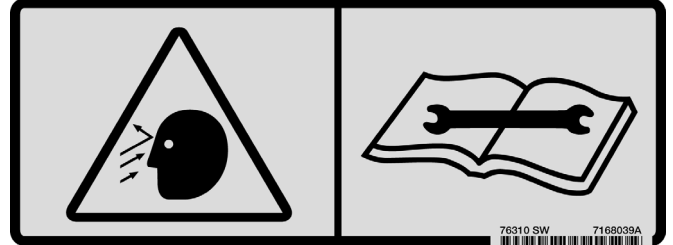

High pressure grease can cause serious injury. Do not loosen grease fitting. Do not loosen bleed fitting more than 1 - 1/2 turns.

Read and understand the Operation & Maintenance Manual for more information.

W-2516-0110

MACHINE SIGNS (DECALS) (CONT'D)

Pictorial Only Safety Signs (Cont'd)

5. General Hazard (7148158)

This safety sign is located inside the operator's area on the right side near the floor.



Failure to obey warning signs and instructions can cause serious injury or death. Never use excavator without instructions. Read and understand the Operation & Maintenance Manual and Handbook.

Keep away from dropoffs, steep areas or banks that could break away.

Explosion or electrocution can occur if machine contacts utility lines or pipes. Check for overhead or underground lines before operating.

Keep bystanders away. No riders. Check location of blade for direction of travel before moving steering controls.

Failure to operate machine from the operator's position can cause serious injury or death.

To Leave Excavator:

1. Lower attachment and blade to ground.
2. Stop engine and remove the key (if equipped).
3. Raise control console.

W-2518-0110

6. Lift Capacity (7359300, 7359301)

This safety sign is located on the ceiling of canopy models and on the right window of cab models.

A		B		kg (lb) @ max. Ø		B		kg (lb) @ max. Ø	
2000 mm [79 in]	3000 mm [118 in]	4000 mm [157 in]	2000 mm [79 in]	3000 mm [118 in]	4000 mm [157 in]	2000 mm [79 in]	3000 mm [118 in]	4000 mm [157 in]	kg (lb) @ max. Ø
3000 mm [118 in]									565 kg (1246 lb) @ 3630 mm (143 in)
2000 mm [79 in]	570 kg [1257 lb]	602 kg [1327 lb]	609 kg (1343 lb) @ 4070 mm (160 in)	570 kg [1257 lb]	374 kg [825 lb]	359 kg (789 lb) @ 4070 mm (160 in)	500 kg [1102 lb]	322 kg [710 lb]	306 kg (675 lb) @ 4070 mm (160 in)
1000 mm [39 in]	154 kg [339 lb]	173 kg [381 lb]	162 kg (359 lb) @ 4270 mm (168 in)	173 kg [381 lb]	369 kg [814 lb]	335 kg (739 lb) @ 4270 mm (168 in)	482 kg [1063 lb]	312 kg [688 lb]	281 kg (619 lb) @ 4270 mm (168 in)
Ground	1939 kg [4275 lb]	1870 kg [4139 lb]	750 kg [1653 lb]	709 kg (1563 lb) @ 4150 mm (163 in)	1058 kg [2322 lb]	854 kg [1871 lb]	367 kg [809 lb]	349 kg (769 lb) @ 4150 mm (163 in)	812 kg [1790 lb]
1000 mm [-39 in]	1194 kg [2639 lb]	1090 kg [2403 lb]	791 kg (1744 lb) @ 3600 mm (142 in)	1166 kg [2571 lb]	579 kg [1276 lb]	428 kg (944 lb) @ 3600 mm (142 in)	884 kg [1949 lb]	482 kg [1063 lb]	358 kg (789 lb) @ 3600 mm (142 in)
2000 mm [-79 in]	1202 kg [2650 lb]		625 kg (1381 lb) @ 3550 mm (140 in)	1202 kg [2650 lb]		625 kg (1381 lb) @ 3550 mm (140 in)	1002 kg [2209 lb]		638 kg (1407 lb) @ 3550 mm (140 in)



Overload can tip the excavator and cause serious injury or death.

- Do not lift or hold any load that exceeds these ratings at their specific load radii and height.
- Total rated load is shown. The weight of all lifting devices must be deducted to determine the net load that can be lifted.

Read and understand the Operation & Maintenance Manual for more information.

W-2519-0110

MACHINE SIGNS (DECALS) (CONT'D)

Pictorial Only Safety Signs (Cont'd)

7. Hot Surfaces and Rotating Fan (7347596)

This safety sign is located inside the engine compartment.



Rotating fan blade can cause serious injury or death. Keep away from fan and moving parts. Do not operate with guard removed.

Hot surfaces can cause injury. Do not touch. Allow to cool before servicing.

W-2521-0106

8. Hot Surfaces (7185935)

This safety sign is located under the right cover.

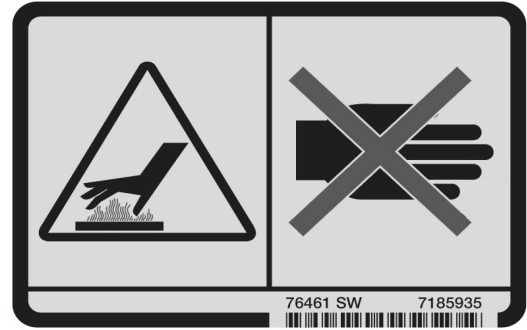

BURN HAZARD

Failure to follow instructions can cause serious burns.

Stop the engine and allow it to cool before removing the radiator cap or adding coolant.

W-2070-0824

9. Stay Away (7169009)

This safety sign is located on the rear of the upperstructure below the tailgate.

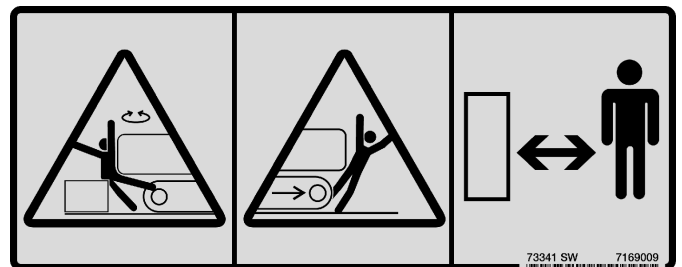

CRUSHING HAZARD

Contact with machine can cause property damage, serious injury or death.

- Keep out of swing area or travel path.
- Always look in the direction of travel.
- Make sure swing area is clear of bystanders and objects.

W-2775-0824

MACHINE SIGNS (DECALS) (CONT'D)

Pictorial Only Safety Signs (Cont'd)

10. Thrown or Flying Objects (7169291)

This safety sign is located on the gas springs under the rear cover and inside the right cover.



IMPACT HAZARD

Opening cylinder can release rod and cause serious injury or death.

- Contents under high pressure.
- Do not open.
- See Service Manual for additional information.

W-2523-1024

11. High Pressure, Battery, Rotating Fan, Exhaust Gases and Service Schedule (7380535)

This safety sign is located inside the right cover. (See SERVICE SCHEDULE on Page 108.)

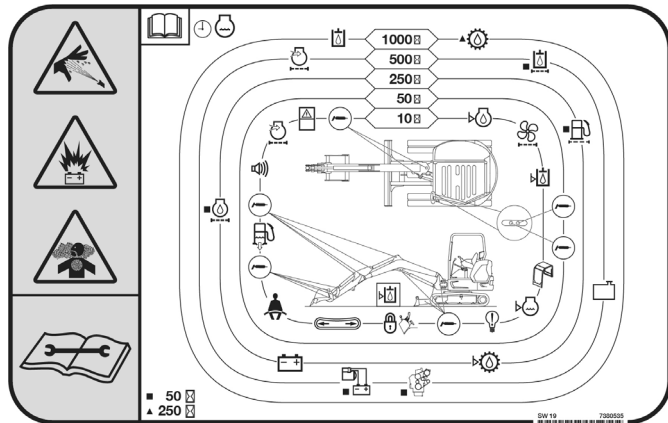

Leaking fluids under pressure can enter the skin and cause serious injury or death. Immediate medical attention is required. Wear goggles. Use cardboard to check for leaks.

Battery makes flammable and explosive gas. Keep arcs, sparks, flames and lighted tobacco away. Keep away from electrical contacts

Rotating fan can cause serious injury. Keep away from fan and moving parts. Do not operate with guard removed.

All exhaust gases can kill. Always ventilate.

Read and understand the Operation & Maintenance Manual for more information.

W-2522-0110

OPERATING INSTRUCTIONS

INTENDED USE	24
INSTRUMENTS AND CONSOLES	25
Cab Interior Light (If Equipped)	25
Left Console	25
Right Console	26
Instrument Panel - Standard (Earlier Models)	27
Instrument Panel — Standard (Later Models)	29
Instrument Panel - Deluxe	32
Radio Option	33
Radio (Bluetooth / DAB+) Option	35
Radio Identification	35
Navigating Audio Menu	35
Navigating System Menu (FM / AM / DAB+ Phone Ready)	36
Pairing A Bluetooth Device	36
Accessing Bluetooth Mode	36
Operating DAB+ Digital Radio	37
Incoming / Outgoing Calls	37
ISO / STD Selector Valve	38
Raising And Lowering The Console	38
Two-Speed Travel	39
Auto Shift Drive Motors	39
Auto Idle Feature	40
OPERATOR CANOPY (ROPS / TOPS / FOPS)	41
Description	41
OPERATOR CAB (ROPS / TOPS / FOPS)	41
Description	41
Cab Door	42
Front Window	43
Front Wiper	44
Window Washer Reservoir	44
Right Side Windows	45
Heating, Ventilation, And Air Conditioning Ducting	46
EMERGENCY EXIT	46
Right Side Rear Window	46
Front Window	46
MOTION ALARM SYSTEM	47
Operation	47
TRAVEL CONTROLS	48
Forward And Reverse Travel	48
Turning	48

HYDRAULIC CONTROLS	50
Description	50
ISO Control Pattern	50
STANDARD Control Pattern	51
Quick Couplers	52
Selectable And Continuous Auxiliary Hydraulic Flow Description	53
Activating Primary Auxiliary Hydraulics With Standard Instrument Panel	53
Activating Primary Auxiliary Hydraulics With Deluxe Instrument Panel (Software Version 88.09 Or Below)	54
Activating Primary Auxiliary Hydraulics With Deluxe Instrument Panel (Software Version 88.10 Or Above)	54
Operating Attachments With Primary Auxiliary Hydraulics	55
Releasing Hydraulic Pressure In Excavator With Standard Instrument Panel	56
Releasing Hydraulic Pressure In Excavator With Deluxe Instrument Panel	56
Releasing Hydraulic Pressure In Attachments	57
Secondary Auxiliary Hydraulics Location	57
Operating Attachments With Secondary Auxiliary Hydraulics (Software Version 88.09 Or Below)	58
Operating Attachments With Secondary Auxiliary Hydraulics (Software Version 88.10 Or Above)	59
Releasing Secondary Auxiliary Hydraulic Pressure In Excavator	60
Releasing Secondary Auxiliary Hydraulic Pressure In Attachment	60
OVERLOAD WARNING DEVICE	61
Description	61
Operation	61
BLADE CONTROL LEVER	61
Raising And Lowering Blade	61
ENGINE SPEED CONTROL	62
Setting Engine Speed (RPM)	62
BOOM SWING	62
Operation	62
BOOM LOAD HOLDING VALVE	63
Description	63
Lowering The Boom With Accumulator Pressure	63
Lowering The Boom With NO Accumulator Pressure	63
ARM LOAD HOLDING VALVE	65
Description	65
Lowering The Arm With Accumulator Pressure	65
Lowering The Arm With NO Accumulator Pressure	65
DAILY INSPECTION	67
Daily Inspection And Maintenance	67

PRE-STARTING PROCEDURE	69
Operation & Maintenance Manual And Operator's Handbook Locations	69
Entering The Excavator	69
Seat Adjustment	70
Seat Belt	70
STARTING THE ENGINE	71
Standard Instrument Panel - Key Start	71
Standard Instrument Panel - Keyless Start	72
Deluxe Instrument Panel - Keyless Start	73
Lowering The Control Console	74
Warming The Hydraulic System	74
Cold Temperature Starting	74
MONITORING THE DISPLAY PANELS	75
Instrument Panel	75
Warning And Shutdown	75
STOPPING THE ENGINE AND LEAVING THE EXCAVATOR	76
Procedure	76
ATTACHMENTS	77
Installing And Removing The Attachment (Pin-On X-Change)	77
Installing And Removing The Attachment (Hydraulic Pin Grabber Quick Coupler)	83
OPERATING PROCEDURE	88
Inspect The Work Area	88
Basic Operating Instructions	88
Lowering The Work Equipment (Engine STOPPED)	88
Object Handling With The Lifting Device	89
Lift Capacity	91
Using The Clamp	93
Driving The Excavator	94
Operating On Slopes	95
Operating In Water	97
Avoiding Track Damage	98
TOWING THE EXCAVATOR	99
Procedure	99
LIFTING THE EXCAVATOR	100
Procedure	100
TRANSPORTING THE EXCAVATOR ON A TRAILER	101
Loading And Unloading	101
Fastening	102

INTENDED USE

This machine is classified as an Excavator as defined in ISO 6165. This machine has tracks and commonly a mounted bucket for the principle intended functions of excavating, loading and backfilling loose materials such as earth, gravel, or crushed rock.

Additional Bobcat approved attachments allow this machine to perform other tasks described in the attachment Operation & Maintenance Manuals.

Examples of intended use include:

Excavating

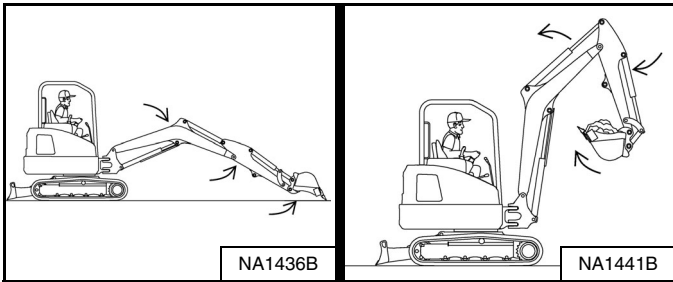

Boom Swing

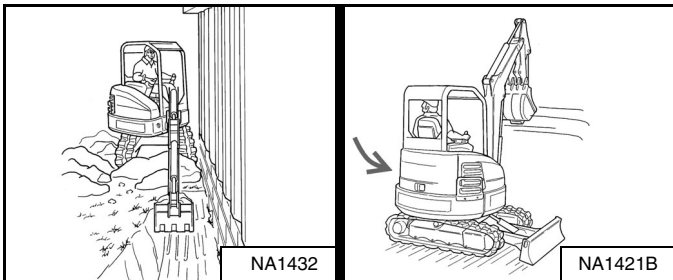

Loading Material

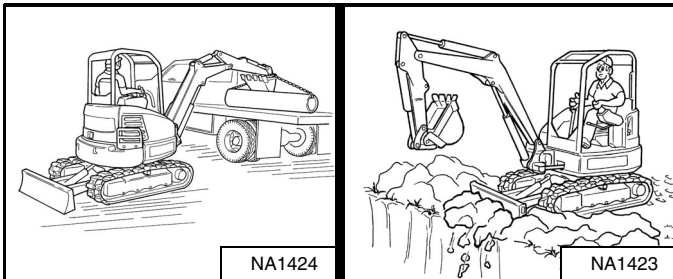

Backfilling

! WARNING

AVOID INJURY OR DEATH

Do not exceed rated lift capacity. Excessive load can cause tipping or loss of control.

W-2374-0500

! WARNING

AVOID INJURY OR DEATH

Check area to be excavated for overhead or underground electrical power lines. Keep a safe distance from electrical power lines.

LINE VOLTAGE	MINIMUM APPROACH DISTANCE
50 kV	At least 3 m (10 ft)
230 kV	At least 5 m (17 ft)
740 kV	At least 10 m (33 ft)

W-2757-0910

! WARNING

IMPACT HAZARD

Grease fitting can come off with great force causing serious injury or death.

Keep bystanders away. Stand on side of boom or lift arm(s) opposite lube fitting when applying or removing tension from digging chain. Use correct fitting to prevent pressure from blowing it off.

W-2119-0824

IMPORTANT

Avoid impacting objects with the blade. Damage to blade and undercarriage components may occur.

I-2256-0507

INSTRUMENTS AND CONSOLES

Cab Interior Light (If Equipped)

Figure 7

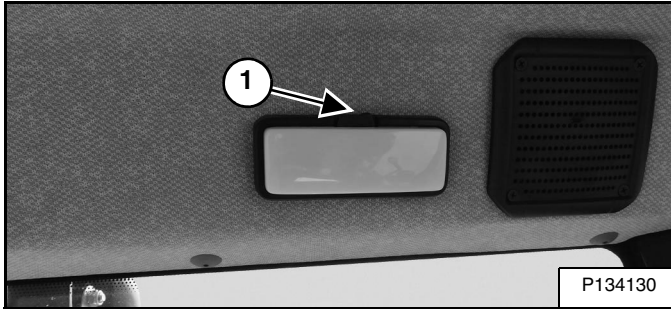

Press the rocker switch on top of the light (Item 1) [Figure 7] to turn the light ON and OFF.

Left Console

Figure 8

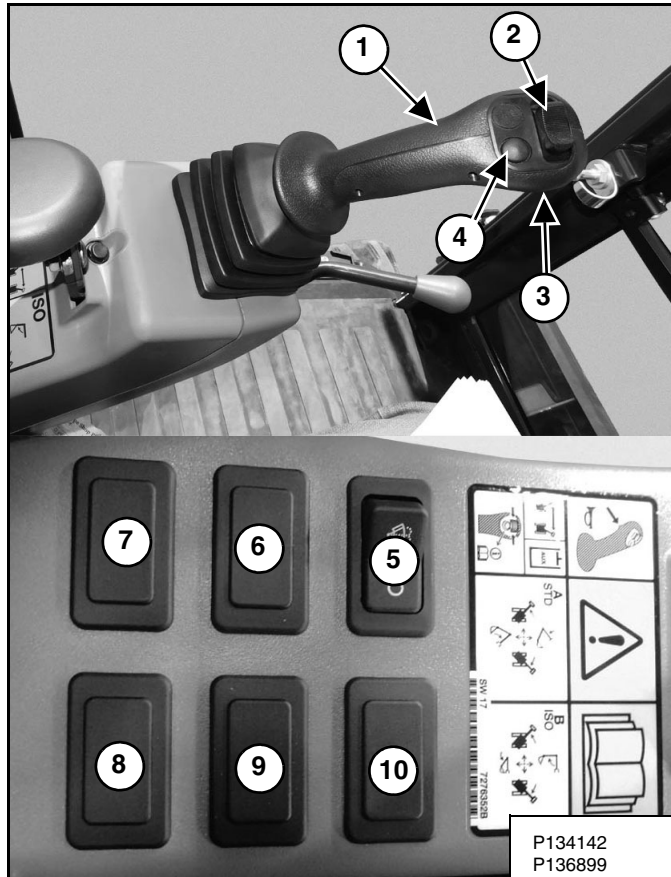

Left Console [Figure 8]

REF. NO	DESCRIPTION	FUNCTION / OPERATION
1	Left Joystick	(See HYDRAULIC CONTROLS on Page 50.)
2	Boom Swing / Secondary Auxiliary Hydraulic Switch	(See BOOM SWING on Page 62.)(See HYDRAULIC CONTROLS on Page 50.)
3	Horn	Press the switch on the bottom of the left joystick to sound the horn.
4	Left Joystick Button	Push the button to toggle between boom swing and optional auxiliary hydraulics (if equipped).
5	Wiper / Washer Switch (if equipped)	Press the switch to the left to turn wiper ON. Press and hold switch to the left to activate window washer. Press the switch to the right to turn wiper OFF.
6	Not used for this model	
7	Beacon / Strobe Light (if equipped)	Press switch to the left to turn ON the Beacon / Strobe light. Press the switch to the right to turn OFF.
8	Not used for this model	
9	Overload Warning Device Switch (if equipped)	Press the switch to the left to activate the Overload Warning Device. Press the switch to the right to deactivate the system. (See OVERLOAD WARNING DEVICE on Page 61.)
10	Not used for this model	

INSTRUMENTS AND CONSOLES (CONT'D)

Right Console

Figure 9

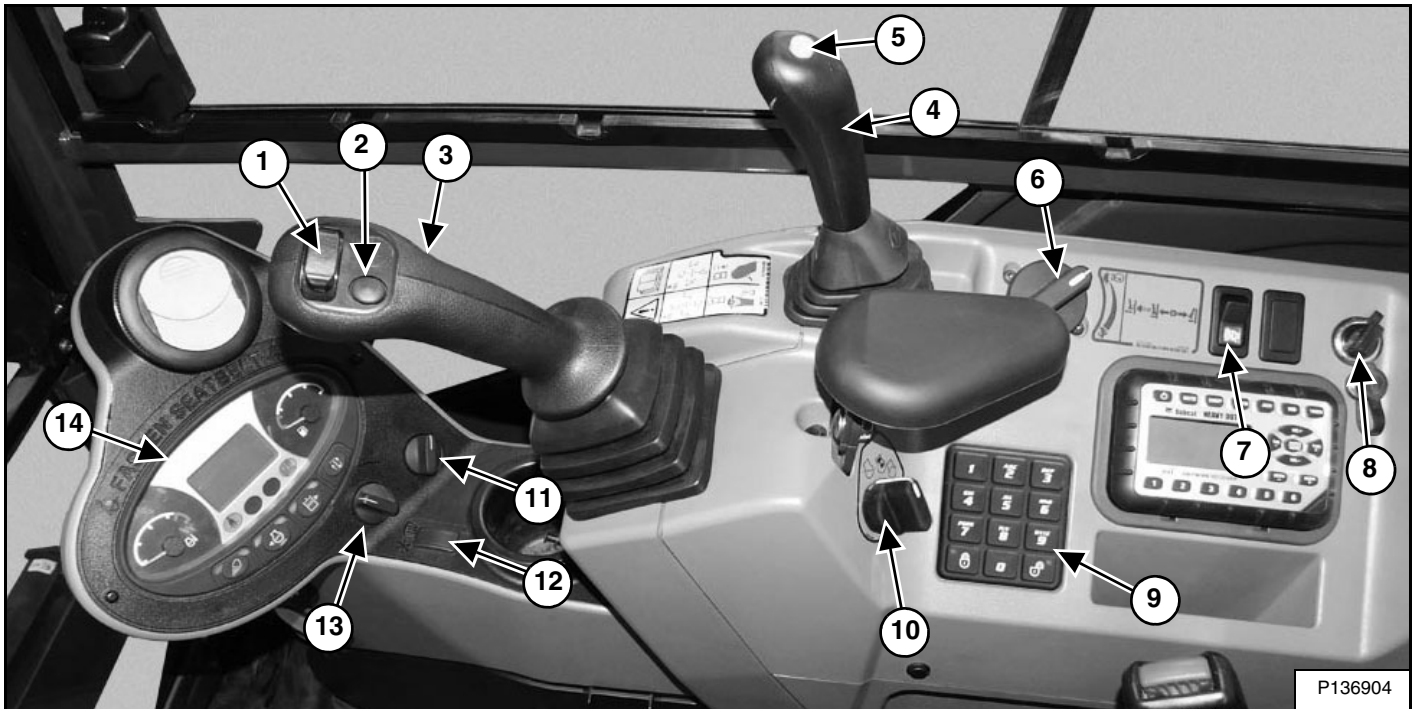

REF	DESCRIPTION	FUNCTION / OPERATION
1	Auxiliary Hydraulic Switch (if equipped)	(See HYDRAULIC CONTROLS on Page 50.)
2	Right Joystick Button	Not used on this model.
3	Right Joystick	(See HYDRAULIC CONTROLS on Page 50.)
4	Blade Control Lever	Controls raising and lowering the blade. Push all the way forward to put blade in float position. (See BLADE CONTROL LEVER on Page 61.)
5	Two-Speed Button	Engages and disengages High Range Travel Speed. (See Two-Speed Travel on Page 39.)
6	Engine Speed Control Dial	Controls rpm of the engine. (See ENGINE SPEED CONTROL on Page 62.)
7	Motion Alarm Cancel Switch	Temporarily disables the motion alarm. (See MOTION ALARM SYSTEM on Page 47.)
8	Auxiliary Power Outlet	12 volt receptacle for accessories.
9	Keypad (if equipped)	Enter the password to start the engine (See Standard Instrument Panel - Keyless Start on Page 72.) (See Deluxe Instrument Panel - Keyless Start on Page 73.)
10	Key Switch or Keyless Start Switch	Always perform the PRE-STARTING PROCEDURE (See PRE-STARTING PROCEDURE on Page 69.) before starting the engine. (See STARTING THE ENGINE on Page 71.)
11	Temperature Control (if equipped)	Turn clockwise to increase temperature; counterclockwise to decrease.
12	Air Conditioning Switch (if equipped)	Press top of switch to turn air conditioner ON (light in switch will be ON). Press bottom of switch to turn OFF.
13	Fan Motor Switch (if equipped)	Turn clockwise to increase fan speed; counterclockwise to decrease.
14	Instrument Panel	(See Instrument Panel - Standard (Earlier Models) on Page 27.) (See Instrument Panel - Deluxe on Page 32.)

NOTE: Always turn key switch and all accessories to OFF position when the engine is stopped, the battery will discharge if the key is left ON.

INSTRUMENTS AND CONSOLES (CONT'D)

Instrument Panel - Standard (Earlier Models)

Figure 10



P-97989

REF	DESCRIPTION	FUNCTION / OPERATION
1	Lights	Press once to turn on work lights. (Left green LED illuminates.) Press again to turn all lights off. (Left green LED off.) Press and hold 5 seconds to display software version in display screen.
2	Auto Idle Feature	Press once to turn Auto Idle Feature ON. (Left green LED illuminates.) Press a second time to turn OFF. (Left and right green LEDs off.) (See Auto Idle Feature on Page 40.)
3	AUX Hydraulic Button	Press once to enable auxiliary hydraulic function. (Left green LED illuminates.) Continue to press and release to scroll through the selectable auxiliary hydraulic settings (3-2-1-OFF). Press and hold (minimum of one second) to enable the continuous flow auxiliary hydraulic feature. (Right green LED illuminates.) Continue to press and release to scroll through the continuous flow selectable auxiliary hydraulic settings (3-2-1-OFF). (See Activating Primary Auxiliary Hydraulics With Standard Instrument Panel on Page 53.)
4	Information	Press to cycle through the following information, which is displayed on the Data Display Screen, Item 6: <ul style="list-style-type: none"> • Hourmeter (On startup) • Job Clock (1 and 2) • Engine rpm • Auxiliary hydraulics information (if equipped) • Battery voltage • Maintenance clock (Press and hold 7 seconds when displayed to reset the maintenance clock.) • Service codes*
5	Engine Temperature Gauge	Shows the engine coolant temperature.

INSTRUMENTS AND CONSOLES (CONT'D)

Instrument Panel - Standard (Earlier Models) (Cont'd)

REF. NO.	DESCRIPTION	FUNCTION / OPERATION
6	Data Display Screen	The data display screen shows the Hourmeter at start up and then changes to engine rpm during normal operation of the excavator. When preheat is activated, the display screen will show the remaining preheat time. Can also be used to display Job Clock, Engine rpm, Auxiliary hydraulics information (if equipped), Battery voltage, Maintenance clock, Service Codes, and Selectable Auxiliary Hydraulic Flow.
7	Fuel Gauge	Shows the amount of fuel in the tank.
8	Seat Belt	Fasten Seat Belt Reminder. Light stays on for 45 seconds to remind operator to fasten seat belt.
9		Not used for this model.
10		Not used for this model.
11	Left Console Lockout	Icon ON when left console is raised. Icon OFF when left console is lowered.
12	General Warning**	Malfunction with one or more machine functions. (See DIAGNOSTIC SERVICE CODES on Page 153.)
13	High Range Engaged***	Icon is illuminated when two-speed travel is enabled.
14	Engine Coolant Temperature**	Engine coolant temperature high or sensor error.
15	Engine Malfunction**	Engine malfunction or failure.
16	Hydraulic System Malfunction**	Hydraulic system malfunction or failure.
17	Fuel	Fuel level low or sensor error. (Icon is ON when fuel level is low, Icon flashes when fuel sensor fault is activated.)
18		Not used for this model.
19		Not used for this model.
20		Not used for this model.
21		Not used for this model.

*See SYSTEM SETUP AND ANALYSIS for Service Code Description. (See DIAGNOSTIC SERVICE CODES on Page 153.)

**Icons will be ON or flashing when diagnostic system indicates a problem. (See DIAGNOSTIC SERVICE CODES on Page 153.)

***Icons will be flashing when diagnostic system indicates a problem. (See DIAGNOSTIC SERVICE CODES on Page 153.)

INSTRUMENTS AND CONSOLES (CONT'D)

Instrument Panel — Standard (Later Models)

Figure 11

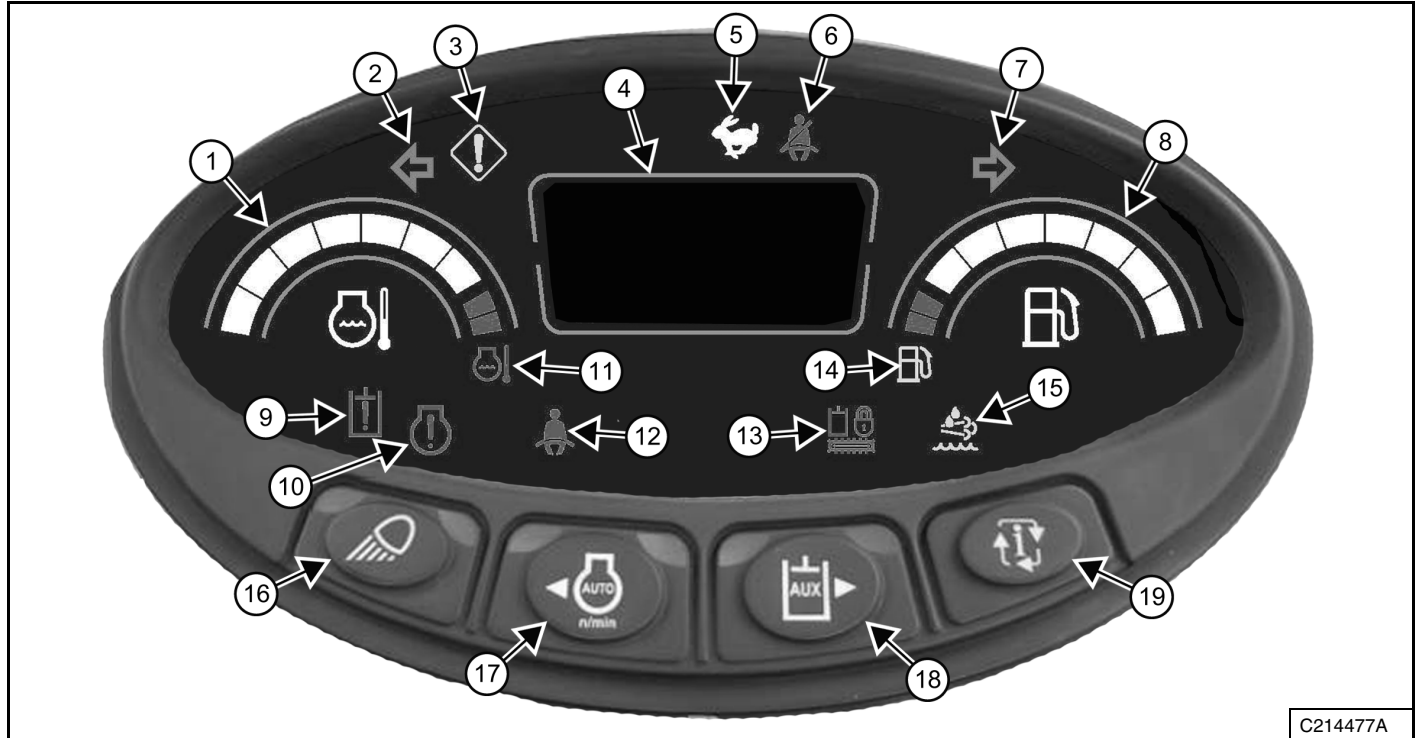

C214477A

REF.	DESCRIPTION	FUNCTION / OPERATION
1	Engine Temperature Gauge	Shows the engine coolant temperature.
2		Not used for this model.
3	General Warning	Turns on or flashes to indicate machine malfunction or failure. (See DIAGNOSTIC SERVICE CODES on Page 153.)
4	Display Screen	Shows the hourmeter at startup and then changes to engine rpm. When preheat is activated, it shows the remaining preheat time.
5	High Range Engaged	Turns on when two-speed travel is enabled. Light flashes to indicate a problem. (See Two-Speed Travel on Page 39.)
6		Not used for this model.
7		Not used for this model.
8	Fuel Gauge	Shows the amount of fuel in the tank.
9	Hydraulic System Malfunction	Turns on or flashes to indicate hydraulic system malfunction or failure.
10	Engine Malfunction	Turns on or flashes to indicate engine malfunction or failure.
11	Engine Coolant Temperature Warning	Turns on or flashes to indicate engine coolant temperature is high or sensor error.
12	Seat Belt	Light stays on for 45 seconds as a reminder to fasten seat belt.
13	Left Console Lockout	Icon is on when left console is raised. Icon is off when left console is lowered. (See Raising And Lowering The Console on Page 38.)
14	Fuel Level Low	Turns on when fuel level is low, flashes to indicate fuel sensor error.
15		Not used for this model.

INSTRUMENTS AND CONSOLES (CONT'D)

Instrument Panel — Standard (Later Models) (Cont'd)

REF.	DESCRIPTION	FUNCTION / OPERATION
16	Lights	Controls work lights. The left green LED will illuminate when lights are turned on. Press and hold five seconds to display software version.
17	Auto Idle (If Equipped)	Engages auto idle.
18	Auxiliary Hydraulics (Used only with joystick switch – activated Auxiliary Hydraulics)	Turns on auxiliary hydraulics. (See Activating Primary Auxiliary Hydraulics With Standard Instrument Panel on Page 53.)
19	Information	Cycles through hourmeter, service codes, and auxiliary hydraulics.

NOTE: Always turn key switch and all accessories to off when the engine is stopped. The battery will discharge if the key is left on.

INSTRUMENTS AND CONSOLES (CONT'D)

Instrument Panel - Standard (Cont'd)

Indicator Icons

The display screen can display the following information:

- Operating hours
- Job Clock (1 and 2)
- Engine rpm
- Auxiliary hydraulics information (if equipped)
- Battery voltage
- Maintenance clock countdown
- Service codes

Figure 12

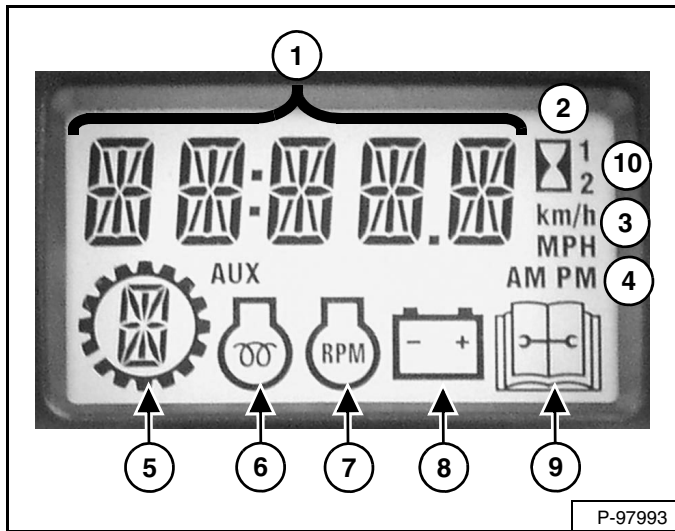

The display screen is shown in [Figure 12]. The data display will show operating hours upon startup.

1. **Data Display**
2. **Hourmeter**
3. **Metric / English (Not Used For This Model)**
4. **Clock (Not Used For This Model)**
5. **Selectable Auxiliary Flow**
6. **Engine Preheat**
7. **Engine RPM**
8. **Battery / Charging Voltage**
9. **Service**
10. **Job Clock (1 and 2)**

INSTRUMENTS AND CONSOLES (CONT'D)

Instrument Panel - Deluxe

Figure 13

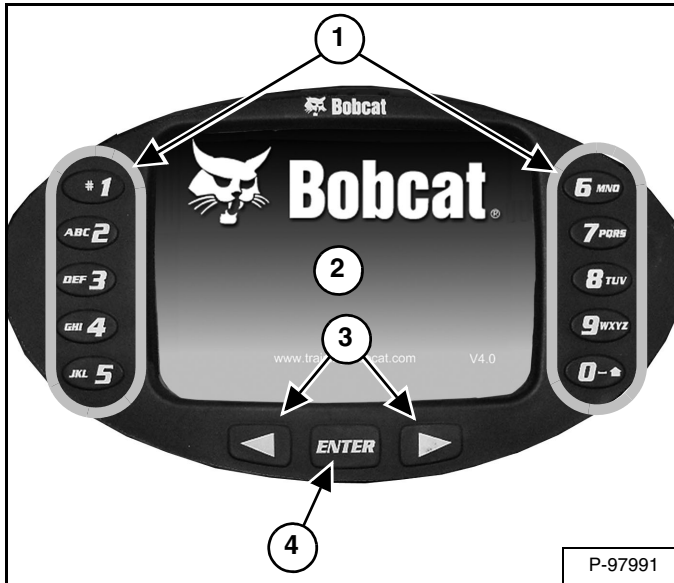

This machine may be equipped with a Deluxe Instrument Panel [Figure 13].

- Keypad (1 through 0):** The keypad has two functions:
 - To enter a number code (password) to allow starting the engine.
 - To enter a number as directed for further use of the display screen.
- Display Screen:** The display screen is where all system setup, monitoring, and error conditions are displayed.
- Scroll Buttons:** Used to scroll through display screen choices.
- ENTER Button:** Used to make selections on the display screen.

Figure 14



Turn the start key to the ON position.

When this screen is on the display you can enter the password and start the engine [Figure 14].

NOTE: Your excavator (with Deluxe Instrument Panel) will have an Owner Password. Your dealer will provide you with this password. Change the password to one that you will easily remember to prevent unauthorized use of your excavator. (See Changing The Owner Password on Page 166.) Keep your password in a safe location for future needs.

Enter The Password:

Use the numbers on the keypad to enter the password, then press the [ENTER] button. A symbol will appear on the display screen for each number entered. The left scroll button can be used to backspace if an incorrect number is entered.

If the correct password is not entered, [INVALID PASSWORD] will appear on the display screen and the password will have to be reentered.

See CONTROL PANEL SETUP for further description of screens to set up the system for your use. (See Panel Setup (Deluxe Instrument Panel) on Page 158.)

Lights

Press keypad [1] [Figure 14] once for FRONT work lights. Press a second time to turn all lights off.

Change Language:

The language can be changed at any time. (See Panel Setup (Deluxe Instrument Panel) on Page 158.)

INSTRUMENTS AND CONSOLES (CONT'D)

Radio Option

Figure 15

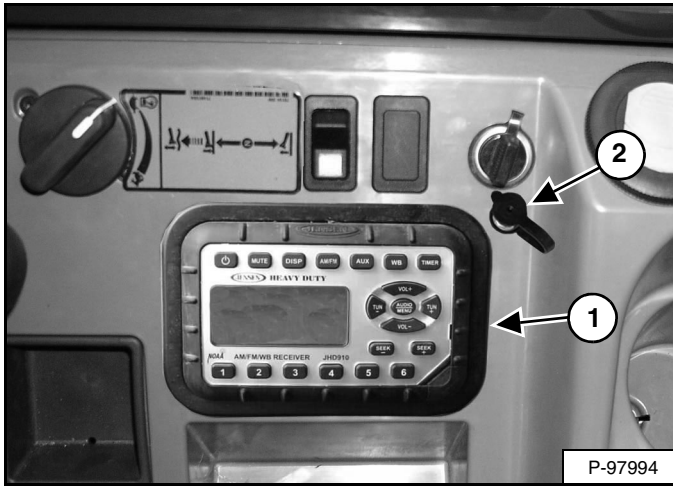

This excavator may be equipped with a radio (Item 1) and the headphone jack (Item 2) [Figure 15].

Figure 16

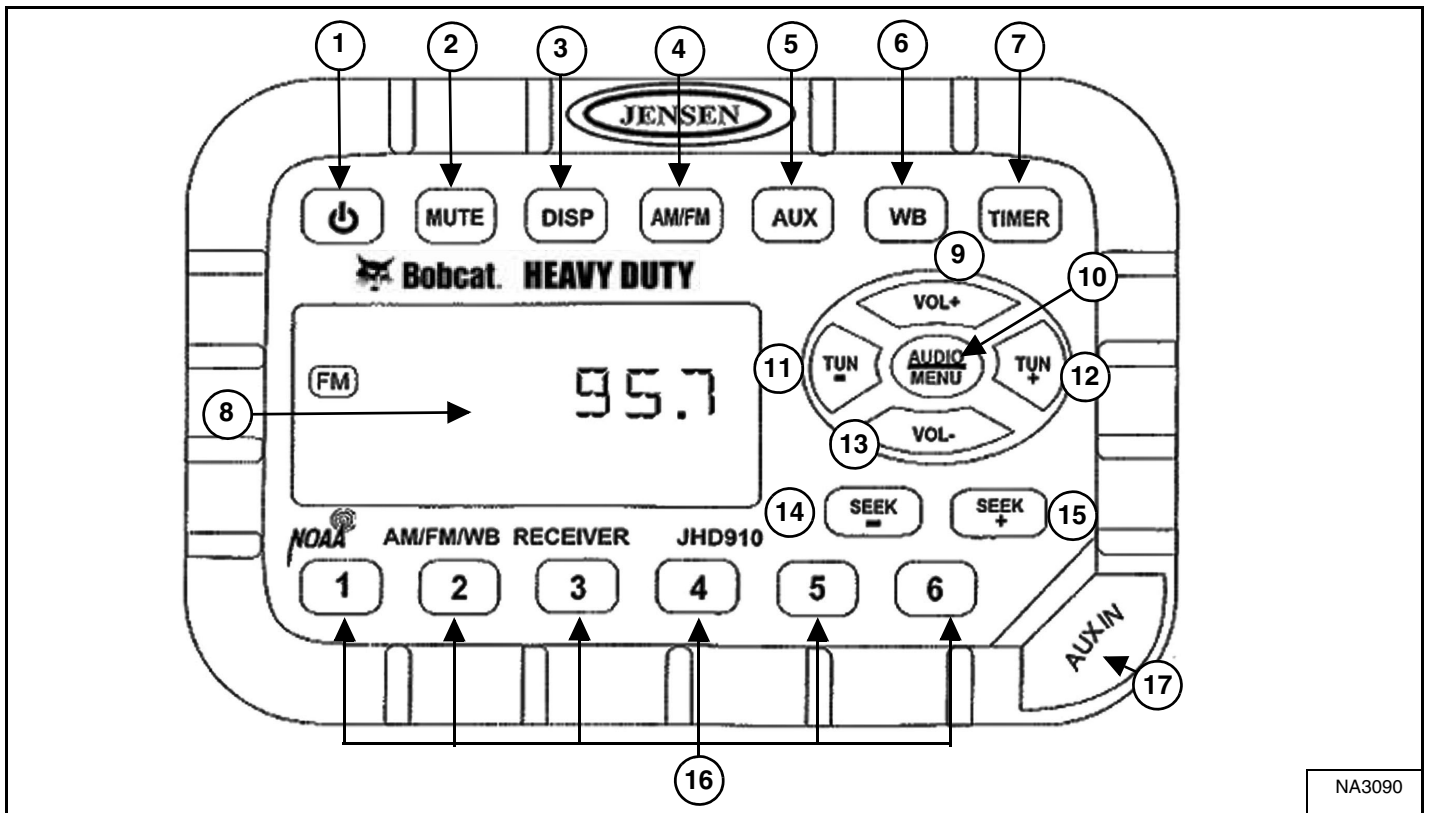

NOTE: See DISPLAY (Item 3) in the following table for clock setting instructions.

INSTRUMENT AND CONSOLES (CONT'D)

Radio (Cont'd)

REF. NO.	DESCRIPTION	FUNCTION / OPERATION
1	POWER	Press to turn ON; press again to turn OFF.
2	MUTE	Press to mute audio output; [MUTE] will appear in display screen; press again to turn OFF.
3	DISPLAY	Press to toggle between function mode (showing tuner frequency, auxiliary input, weather band information, or timer) and clock mode. Press and hold to enter clock setting mode; use FREQUENCY DOWN (TUN -) button to adjust hours and FREQUENCY UP (TUN +) button to adjust minutes; normal operation will resume automatically.
4	BAND	Press to select tuner mode. Press to cycle through 2 AM (MW) bands and 3 FM bands.
5	AUXILIARY	Press to select Auxiliary Input mode. Portable audio device (MP3 player) must be attached to auxiliary input jack.
6	WEATHER BAND	Press to select weather band; use FREQUENCY UP (TUN +) and FREQUENCY DOWN (TUN -) buttons to adjust to the clearest station. The weather alert feature, if activated, will automatically switch from the current function to the weather band if a weather warning is received. See AUDIO / MENU ADJUSTMENT in this table.
7	TIMER	Press to access timer mode. Press to start the timer function; press again to stop timer; press again to resume timer or press and hold to reset timer and exit from timer mode.
8	DISPLAY SCREEN	Displays the time, frequency, and activated functions.
9	VOLUME UP	Adjusts volume up; current volume (0 – 40) will appear briefly in display screen.
10	AUDIO / MENU ADJUSTMENT	AUDIO ADJUSTMENT: Press to cycle through bass, treble, and balance settings; use VOLUME UP (VOL +) and VOLUME DOWN (VOL -) buttons to adjust when desired option is displayed; normal operation will resume automatically. MENU ADJUSTMENT: Press and hold for 3 seconds to enter menu adjustment settings; press to cycle through the following settings; use VOLUME UP (VOL +) and VOLUME DOWN (VOL -) buttons to adjust when desired option is displayed; normal operation will resume automatically. <ul style="list-style-type: none"> • Beep Confirm (On or Off) - Determines if beep will sound with each button press. • Operation Region (USA or Europe) - Selects the appropriate region. • Clock Display (12 or 24) - Selects a 12-hour or 24-hour clock display. • Display Brightness (Low, Medium, or High) - Determines brightness level of display screen. • Backlight color (Amber or Green) - Determines backlight color of display screen. • Power On Volume (0 - 40) - Selects default volume setting when radio is turned on. • WB Alert (On or Off) - Determines if weather band alert feature is activated.
11	FREQUENCY DOWN	Press to manually tune the radio frequency down.
12	FREQUENCY UP	Press to manually tune the radio frequency up.
13	VOLUME DOWN	Adjusts volume down; current volume (0 - 40) will appear briefly in display screen.
14	SEEK FREQUENCY DOWN	Press to automatically tune frequency down to next strong station.
15	SEEK FREQUENCY UP	Press to automatically tune frequency up to next strong station.
16	PRESET STATIONS	Used to store and recall stations for each AM and FM band. Press and hold to store current station; press button to recall station.
17	AUXILIARY INPUT JACK	Connect line output of portable audio device (MP3 player) to 3,5 mm (1/8 in) jack and press AUXILIARY button.

INSTRUMENTS AND CONSOLES (CONT'D)

Radio (Bluetooth / DAB+) Option

Radio Identification

Figure 17

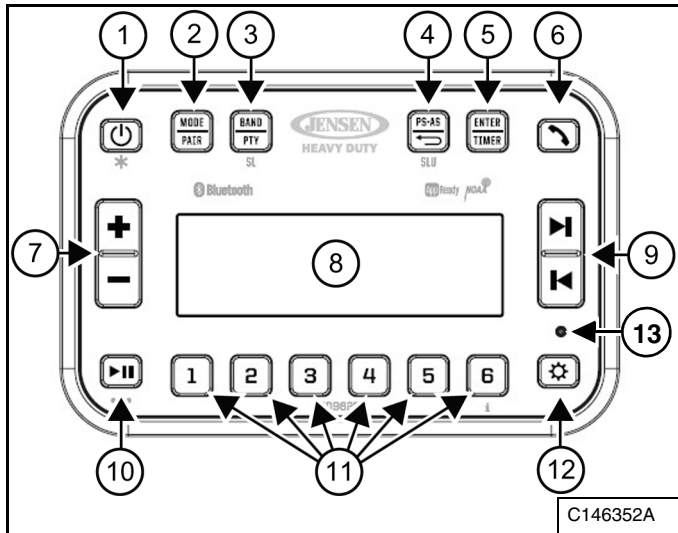

REF	DESCRIPTION	FUNCTION
1		Power button.
2	MODE PAIR	Press to select mode or to pair device.
3	BAND PTY	Press to select: FM1, FM2, FM3, AM1, AM2, DAB+1, DAB+2 DAB+3.
4	PS-AS 	Preset Scan / Automatically Store: Press to scan stations stored in the current band. Press and hold for 2 seconds to store a stations.
5	ENTER TIMER	(See Navigating System Menu (FM / AM / DAB+ Phone Ready) on Page 36.)
6		(See Incoming / Outgoing Calls on Page 37.)
7	+ -	Press to adjust ranges or volume.
8	Display Screen	Displays the time, frequency, and activated functions.
9		Press to navigate menu. (See Navigating System Menu (FM / AM / DAB+ Phone Ready) on Page 36.)

REF	DESCRIPTION	FUNCTION
10		Press to pause or mute audio output.
11	Preset Stations	Press and hold a button to store current station. Press to recall station.
12		Press to access settings menus. (See Navigating System Menu (FM / AM / DAB+ Phone Ready) on Page 36.)
13	Reset	Press if the display screen shows an error code.

Navigating Audio Menu

1. Press the settings button (Item 12) **[Figure 17]** to access the audio menu.
2. Navigate through the audio menu by pressing the navigation buttons (Item 9) **[Figure 17]**.
3. Once the desired menu item is on the display (Item 8), adjust the option by pressing the + / - buttons (Item 7) **[Figure 17]** withing five seconds.

The following items can be adjusted:

- Loudness
- Bass Level
- Treble Level
- Balance.

INSTRUMENTS AND CONSOLES (CONT'D)

Radio (Bluetooth / DAB+) Option (Cont'd)

Navigating System Menu (FM / AM / DAB+ Phone Ready)

1. Press and hold the settings button (Item 12) **[Figure 17]** for more than 2 seconds to access the system menu.
2. Navigate through the system menu by pressing the navigation buttons (Item 9) **[Figure 17]**.
3. Once the desired menu item appears on the display, adjust that option by pressing the PS-AS button (Item 4) **[Figure 17]**.
4. Press the Enter / Timer button (Item 5) **[Figure 17]** to select the desired item.

The following items can be adjusted:

- LCD Dimmer
- Bluetooth Devices
- Clock Set
- Low Voltage Alarm (On / Off)
- Low Voltage Auto Off (On / Off)
- Preset-Only Tune (On / Off)
- Tuning Region
- USA Tuning Region (AM / FM / WX / Bluetooth)
- Europe Tuning Region (AM / FM / DAB+ / Bluetooth)
- Japan Tuning Region (AM / FM / Bluetooth)
- DAB+
 - New Flash (On / Off)
 - Transport Flash (On / Off)
- Area Weather Flash (On / Off)
 - Warning / Service (On / Off)
 - Event Announcement (On / Off)
 - Antenna Power (On / Off)
 - Clock Sync (On / Off)

Pairing A Bluetooth Device

1. On your personal Bluetooth device, enter the Bluetooth settings list. Make sure your device has Bluetooth turned on and is searching for new devices.
2. Press and hold the Mode / Pair button (Item 2) **[Figure 17]** for 3 seconds to make the radio available on your Bluetooth device.
3. Select JHD962BT on your Bluetooth device.

Enter pairing password (0000) if required.

Accessing Bluetooth Mode

You can play your stored music when your phone has been paired to the Bluetooth radio.

1. During playback, press the navigation buttons (Item 9) **[Figure 17]** to play the previous or next track.
2. During playback, press the pause / mute button (Item 10) **[Figure 17]** to pause the Bluetooth player.

Press again to resume playback.

INSTRUMENTS AND CONSOLES (CONT'D)

Radio (Bluetooth / DAB+) Option (Cont'd)

Operating DAB+ Digital Radio

NOTE: The DAB+ Digital Radio operates only if the machine has the antenna installed. If the antenna is not installed, the DAB+ Digital Radio will not work.

Digital Audio Broadcasting (DAB / DAB+) is designed for delivery of high-quality digital audio programs and data services from terrestrial transmitters in the Very High Frequency (VHF) frequency bands.

For more information about (DAB / DAB+) services and to find a list of stations available in your area, visit www.worlddab.org.

- Selecting A Band

Press the Band / PTY button (Item 3) [Figure 17] to change between DAB+1, DAB+2, and DAB+3 band.

- Updating The Service List

Press the PS-AS button (Item 4) to start service list update. The "Service List Updating" will display and start updating the service list. Press the PS-AS button (Item 4) [Figure 17] to cancel service list update.

- Selecting A Service

Press and hold the Band / PTY button (Item 3) to display the service list menu. While in service list, press the navigation buttons (Item 9) [Figure 17] to navigate down or up the service list.

Press the Enter / Timer button (Item 5) [Figure 17] to select the desired service label and the system exits to the current selected service label screen.

- Selecting An Ensemble

Press the navigation buttons (Item 9) [Figure 17] to automatically search for an available ensemble, service, or component to play.

Press the navigation buttons (Item 9) [Figure 17] manually select an ensemble.

Press the Enter / Timer button (Item 5) [Figure 17] to confirm.

- Storing Or Recalling A Service

Six numbered buttons (Item 11) [Figure 17] store or recall a service.

To store a station, select the desired station and then press and hold one of the six pre-set buttons (Item 11) for two seconds. The pre-set number will appear in the display screen (Item 8) [Figure 17].

To recall a station, press the desired pre-set button (Item 11) [Figure 17] to select the corresponding stored station.

Incoming / Outgoing Calls

NOTE: Not all machines are equipped with the phone feature. The phone button (Item 6) operates only if the machine has the microphone installed. If the microphone is not installed, the phone (Item 6) [Figure 17] will not work. When the mobile device is connected through Bluetooth, the phone number of incoming calls will appear on the display.

The incoming call ring tone will play through the unit. While the mobile device is connected through Bluetooth, the phone number for incoming calls will appear on the display screen. The incoming ring will be output through the unit.

- Answering An Incoming Call

If the Bluetooth Auto Answer is off, press the call button (Item 6) [Figure 17]. If the Bluetooth Auto Answer is on, the unit will answer the call automatically after 5 seconds of ringing.

- Transferring A Call

During a call, press and hold phone button (Item 6) [Figure 17] to transfer the call between the unit and the mobile device.

- Rejecting An Incoming Call

Press and hold the phone button (Item 6) [Figure 17] to reject the incoming call.

- Making An Outgoing Call

Press the phone button (Item 6) [Figure 17] to dial the last called number.

- Turning Auto Answer On And Off

Press the + / - button (Item 7) [Figure 17] to turn the Auto Answer function on or off.

INSTRUMENTS AND CONSOLES (CONT'D)

ISO / STD Selector Valve

The excavator may be equipped with an ISO / STD selector valve located in the compartment below the operator's seat.

Figure 18

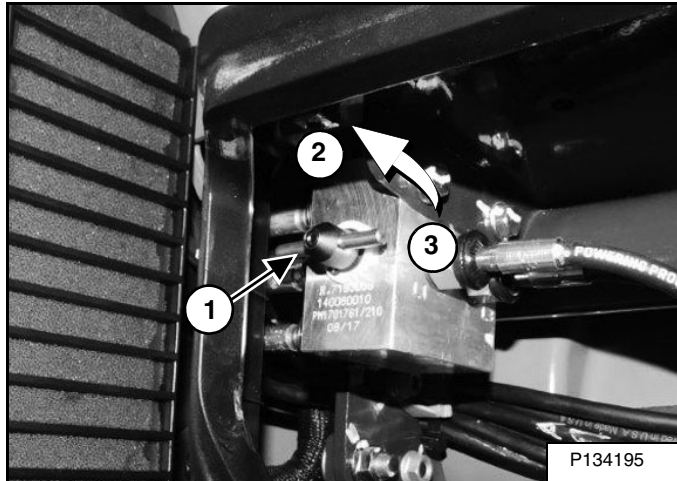

The joystick hydraulic function can be switched from ISO control pattern to Standard pattern.

Open the compartment under the operator's seat to access the selector valve.

Rotate the lever (Item 1) counterclockwise to select STANDARD Control Pattern (Item 2). Rotate the lever clockwise (Item 3) to select ISO Control Pattern [Figure 18].

Raising And Lowering The Console

Raise the console before exiting the cab.

Figure 19



Pull up on the release handle [Figure 19]. The lift spring will assist in raising the console.

Lower the console before operating the excavator.

Push down on the lever [Figure 19] until the latch is engaged.

NOTE: When the console is raised, the hydraulic and traction system functions are locked and will not operate.

If the engine stops, the boom / bucket (attachments) can be lowered to the ground using hydraulic pressure in the accumulator.

The control console must be in the locked down position, and the key switch in the ON position.

INSTRUMENTS AND CONSOLES (CONT'D)

Two-Speed Travel

Figure 20

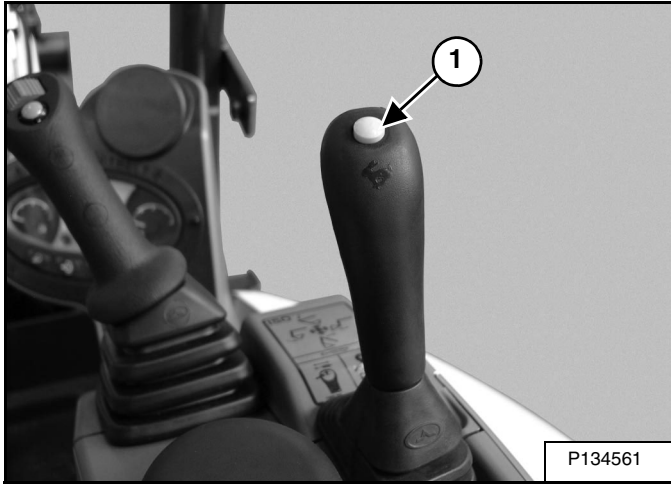

Press the button (Item 1) [Figure 20] to engage the high range. Press a second time to disengage.

Figure 21



When high range is engaged, the two-speed travel icon (Item 1) [Figure 21] will illuminate.

Press the button (Item 1) [Figure 20] again to disengage.

Auto Shift Drive Motors

The travel motors are equipped with an auto shift feature that senses hydraulic pressure. When in high range, the travel motors will automatically shift to low range when more torque is required and return to high range when hydraulic pressure decreases.

NOTE: Always set the travel speed to low range when loading or unloading the excavator onto a transport vehicle.

INSTRUMENTS AND CONSOLES (CONT'D)

Auto Idle Feature

The auto idle feature (when engaged) will reduce the engine speed to low idle when the control levers (joystick, blade, travel, etc.) are in NEUTRAL and not used for approximately four seconds. The engine rpm will return to the set position as soon as any control lever is activated.

NOTE: Auto idle is only available on machines equipped with a dial throttle.

Standard Panel

Figure 22

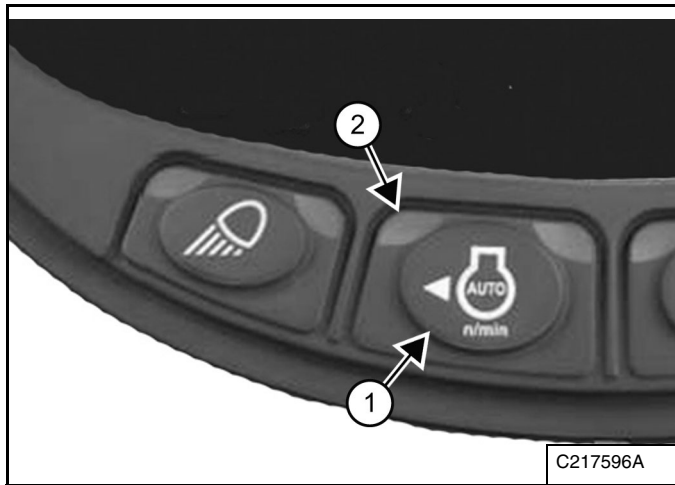

The Automatic Idle switch (Item 1) [Figure 22] is used to engage or disengage the automatic idle feature.

Press the switch (Item 1) once to engage automatic idle and the LED (Item 2) will illuminate. Press the switch (Item 1) a second time to disengage automatic idle, the LED (Item 2) [Figure 22] will be OFF.

NOTE: Always disengage the auto idle feature when loading or unloading the excavator onto a transport vehicle.

Deluxe Panel

Figure 23

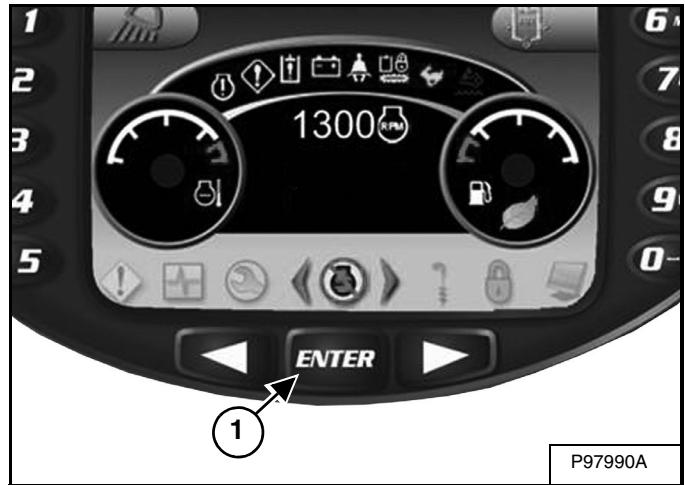

Press ENTER (Item 1) once to engage automatic idle. Press ENTER (Item 1) [Figure 23] again and auto idle will be OFF.

NOTE: Always disengage the auto idle feature when loading or unloading the excavator onto a transport vehicle.

NOTE: When equipped with the deluxe instrument panel, the time delay for auto idle to activate can be adjusted. (See Auto Idle Time Delay on Page 160.)

OPERATOR CANOPY (ROPS / TOPS / FOPS)

Description

The Bobcat excavator has an operator canopy (ROPS / TOPS / FOPS) as standard equipment to protect the operator if the excavator is tipped over or from falling objects. The seat belt must be worn for ROPS / TOPS / FOPS protection.

Check the ROPS / TOPS / FOPS canopy, mounting, and hardware for damage. Never modify the ROPS / TOPS / FOPS canopy. Replace the canopy and hardware if damaged. See your Bobcat dealer for parts.

ROPS / TOPS - Roll-Over Protective Structure per ISO 12117-2, and Tip-Over Protective Structure per ISO 12117.

FOPS - Falling Objects Protective structure, Top Guard per ISO 10262 - Level 1.



MODIFICATION HAZARD

Cab changes can cause loss of operator protection from rollover and falling objects resulting in serious injury or death.

Never modify operator cab by welding, grinding, drilling holes or adding attachments unless instructed to do so by Bobcat.

W-2069-0824

OPERATOR CAB (ROPS / TOPS / FOPS)

Description

The Bobcat excavator has an optional operator cab (ROPS / TOPS / FOPS) as standard equipment to protect the operator if the excavator is tipped over or from falling objects. The seat belt must be worn for ROPS / TOPS / FOPS protection.

Check the ROPS / TOPS / FOPS cab, mounting, and hardware for damage. Never modify the ROPS / TOPS / FOPS cab. Replace the cab and hardware if damaged. See your Bobcat dealer for parts.

ROPS / TOPS - Roll-Over Protective Structure per ISO 12117-2, and Tip-Over Protective Structure per ISO 12117.

FOPS - Falling Objects Protective structure, Top Guard per ISO 10262 - Level 1.



MODIFICATION HAZARD

Cab changes can cause loss of operator protection from rollover and falling objects resulting in serious injury or death.

Never modify operator cab by welding, grinding, drilling holes or adding attachments unless instructed to do so by Bobcat.

W-2069-0824

OPERATOR CAB (ROPS / TOPS / FOPS) (CONT'D)

Cab Door

Figure 24

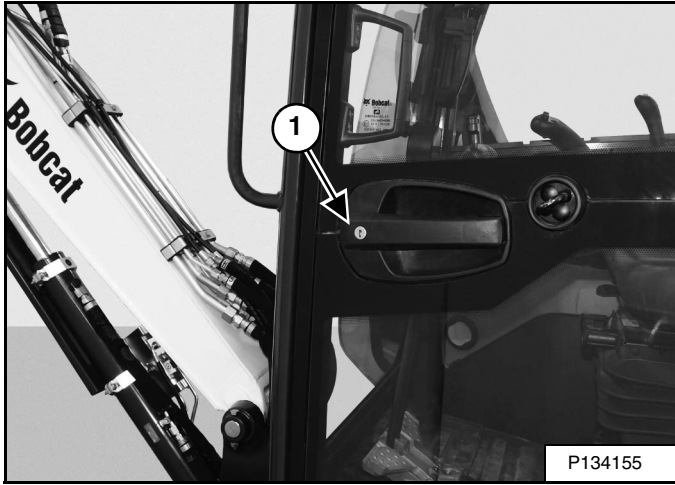

The cab door can be locked (Item 1) [Figure 24] with the same key as the starter switch.

Figure 26

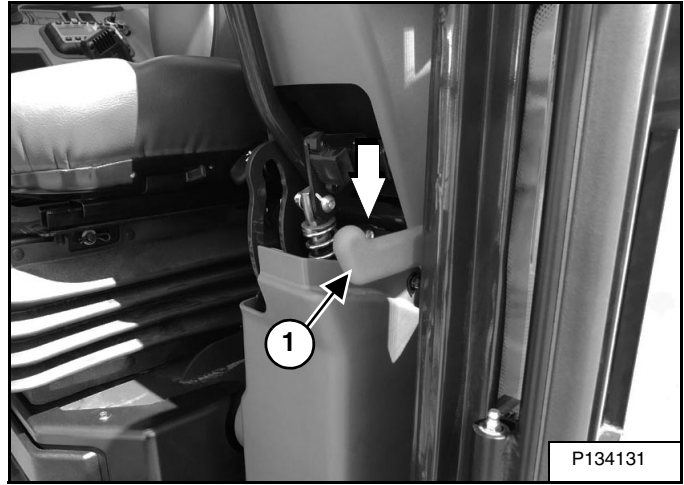

When the door is in the open position, push down on the latch (Item 1) [Figure 26] to close the door.

Figure 25

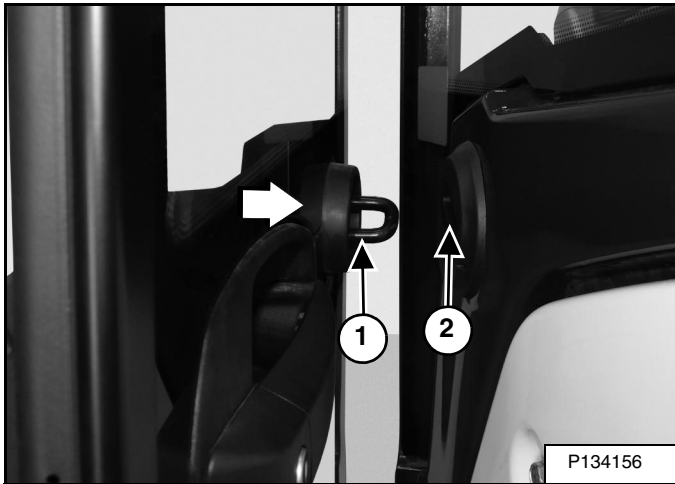

Push the door all the way open until the latch post (Item 1) engages in the latch (Item 2) [Figure 25] to hold the door in the open position.

Figure 27

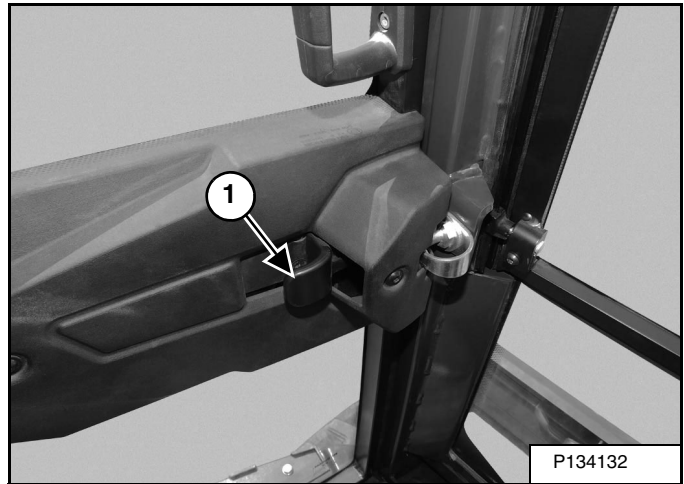

From inside the cab, open the door using the handle (Item 1) [Figure 27].

OPERATOR CAB (ROPS / TOPS / FOPS) (CONT'D)

Front Window

Opening The Front Window

Figure 28

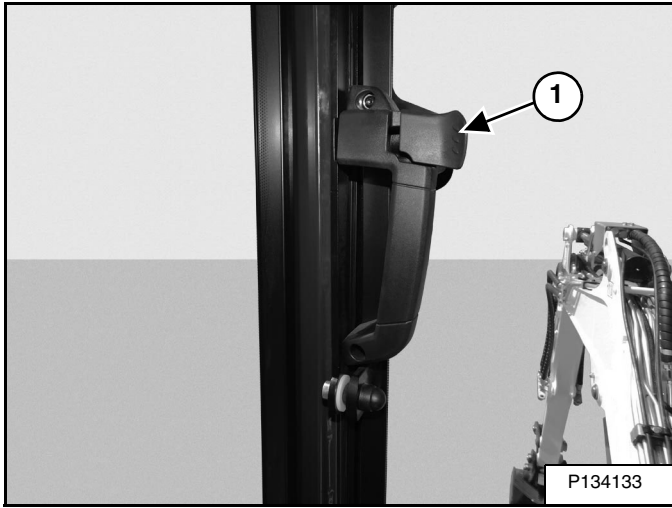

Push the window latch buttons (Item 1) **[Figure 28]** on both sides.

Figure 29



Use both window grab handles (Item 1) **[Figure 29]** to pull the top of the window in.

Continue moving the window in and up over the operator's head until the window is fully raised.

Figure 30

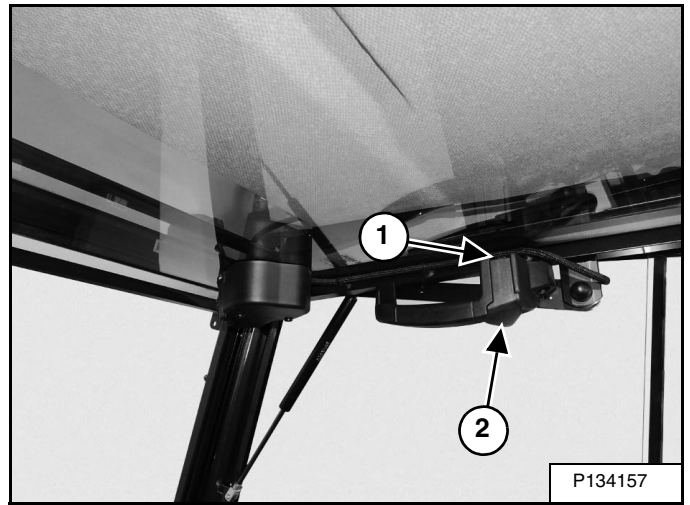

When the window is fully raised, the latch (Item 1) **[Figure 30]** (both sides) will close on the bracket in the latched position.

Pull down and forward slightly on the window to make sure it is fully latched.

Closing The Front Window

Use both window grab handles to support the window while pressing the window latch button (Item 2) **[Figure 30]** (both sides).

Use both window grab handles (Item 1) **[Figure 29]** to pull the window down fully.

Press the top of the window in until the latch locks into the latched position (both sides) **[Figure 28]**.

Pull inward and upward slightly on the window to make sure it is fully latched in the closed position.

OPERATOR CAB (ROPS / TOPS / FOPS) (CONT'D)

Front Wiper

Figure 31

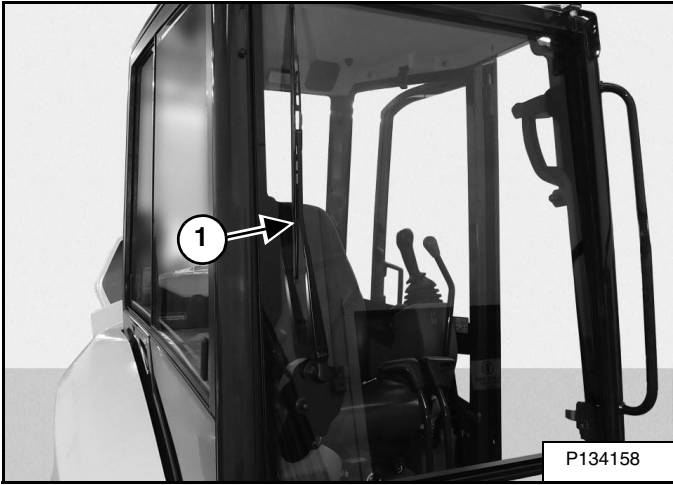

The front window is equipped with a wiper (Item 1) [Figure 31] and washer.

Window Washer Reservoir

Figure 32

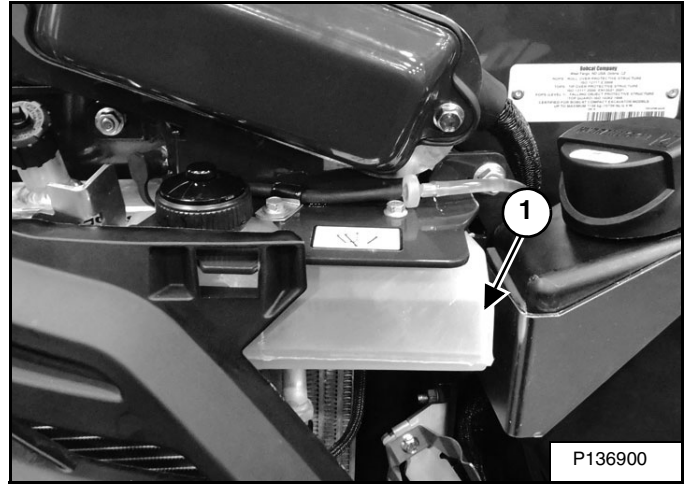

The window washer reservoir (Item 1) [Figure 32] is located under the right side cover.

OPERATOR CAB (ROPS / TOPS / FOPS) (CONT'D)

Right Side Windows

Opening The Right Rear Window

Figure 33

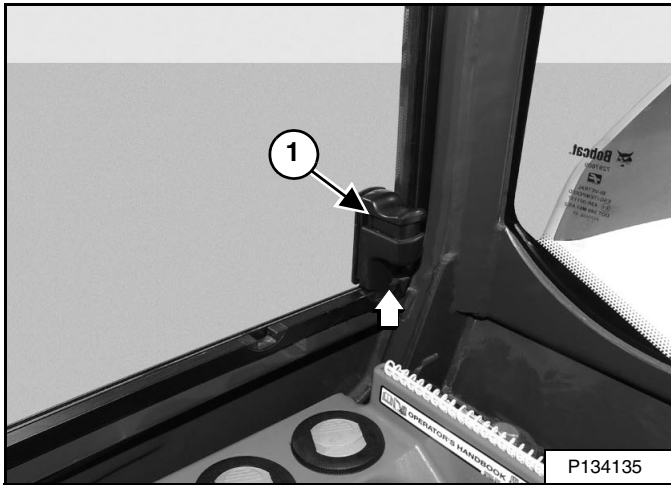

Pull up on the bottom latch (Item 1) [Figure 33].

Figure 34

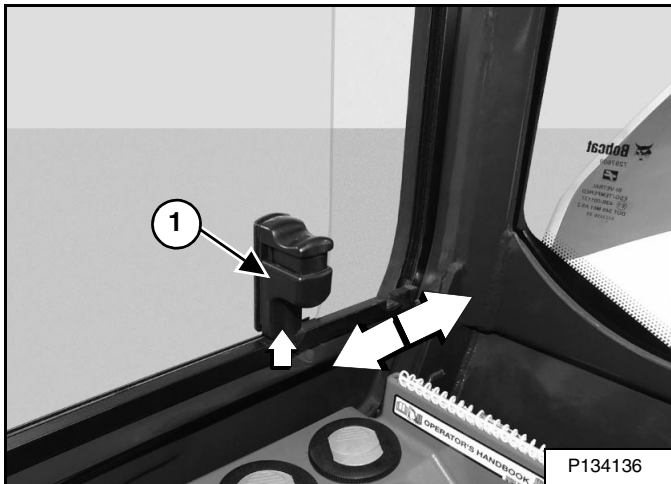

Pull the latch (Item 1) [Figure 34] forward to open the window until the desired stop. Release the bottom latch and snap the lock in place.

Closing The Right Rear Window

Pull up on the bottom latch (Item 1) [Figure 33] and push the latch back to close the window.

Opening The Right Front Window

Figure 35

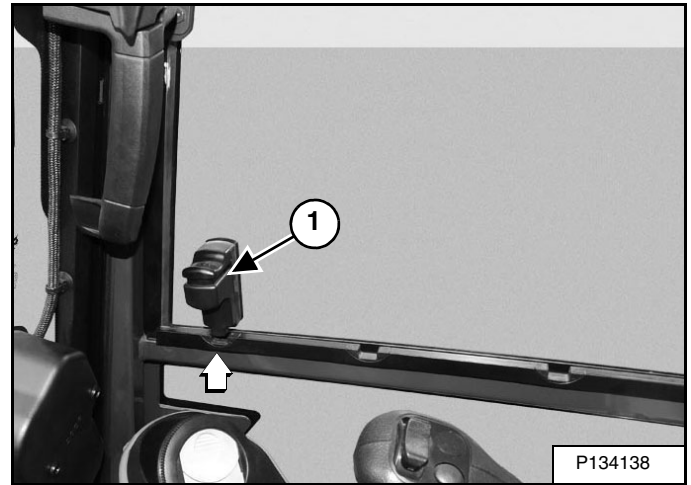

Pull up on the bottom latch (Item 1) [Figure 35] located at the front of the front window.

Figure 36

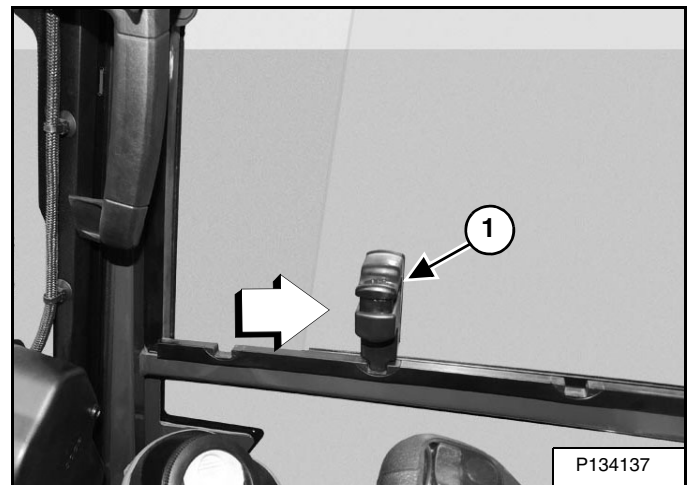

Pull the latch (Item 1) [Figure 36] backward to open the window until the desired stop. Release the bottom latch and snap the lock in place.

Closing The Right Front Window

Pull up on the bottom latch (Item 1) [Figure 35] and push the latch forward to close the window.

OPERATOR CAB (ROPS / TOPS / FOPS) (CONT'D)

Heating, Ventilation, And Air Conditioning Ducting

Figure 37

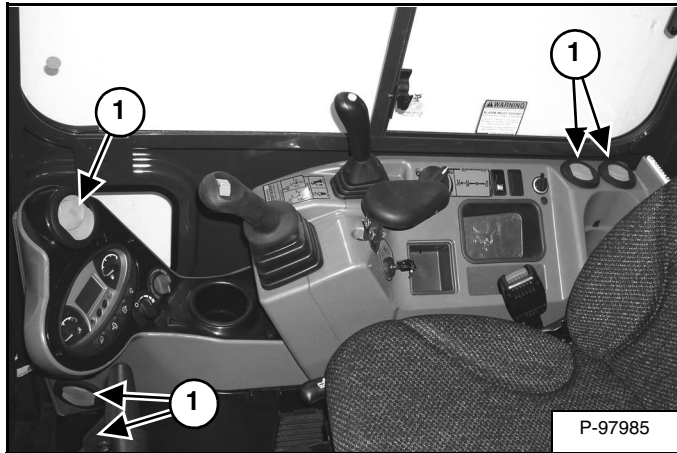

The HVAC louvers (Item 1) [Figure 37] can be positioned as needed to direct the air flow to various areas in the cab.

EMERGENCY EXIT

The door, the right side rear window and the front window provide exits.

Right Side Rear Window

Figure 38



Exit through the window [Figure 38].

Front Window

Figure 39



Open the front window and exit [Figure 39].

NOTE: If the excavator has a Front Guard Kit installed, the front window is NOT an emergency exit.

MOTION ALARM SYSTEM

Operation

Figure 40

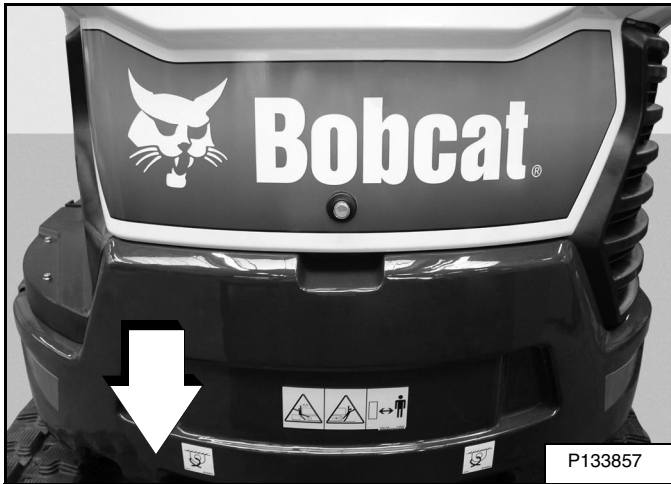

This excavator can be equipped with a motion alarm system. The motion alarm is located underneath the rear of the excavator.

Figure 41

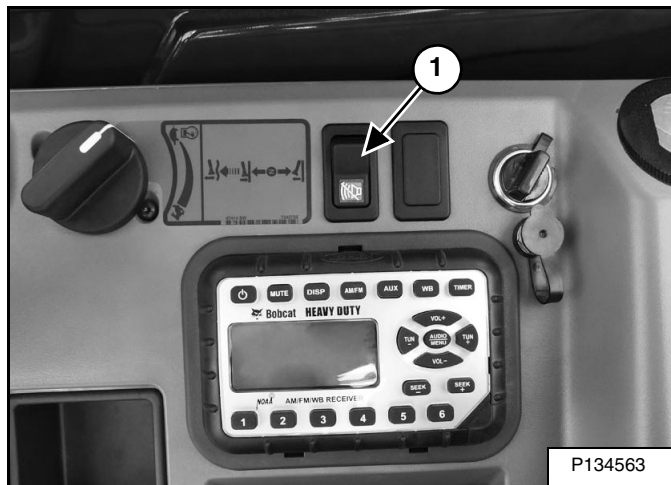

The motion alarm can be temporarily disabled by pressing the Motion Alarm switch (Item 1) [Figure 41] while the machine is moving. As soon as the travel levers are returned to the NEUTRAL position, the motion alarm will be enabled.

WARNING

This machine is equipped with a motion alarm.
ALARM MUST SOUND!
when operating forward or backward.

Failure to maintain a clear view in the direction of travel could result in serious injury or death.

The operator is responsible for the safe operation of this machine.

W-2786-0309

The motion alarm will sound when the operator moves the travel control levers (Item 1) [Figure 42] in either the forward or reverse direction.

If the alarm does not sound, or for adjustment instructions, see inspection and maintenance instructions for the motion alarm system in the preventive maintenance section of this manual. (See MOTION ALARM SYSTEM on Page 112.)

TRAVEL CONTROLS

Forward And Reverse Travel

NOTE: The following procedures describe forward, reverse, left and right as seated in the operator's seat.

Figure 42

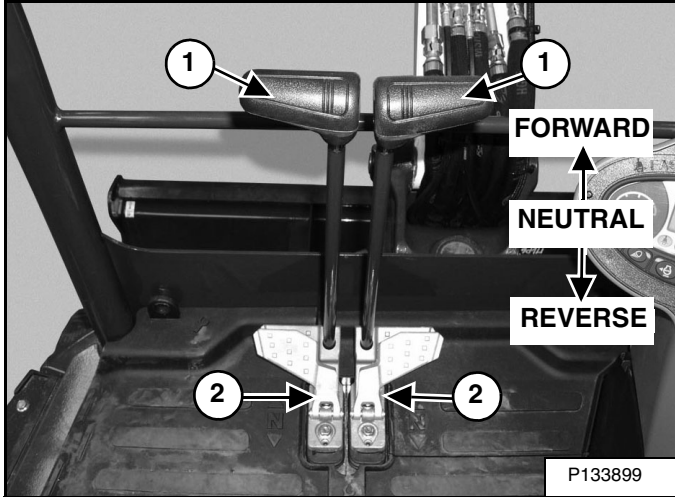

Position the blade so it is at the front of the machine (as you sit in the operator's seat). Slowly move both steering levers* (Item 1) [Figure 42] forward for forward travel; backward for reverse travel.

* Travel can also be controlled with foot pedals (Item 2) [Figure 42]. Pivot the heel of the pedals forward for additional space on the floor.

WARNING

AVOID INJURY OR DEATH

- Check the blade location before traveling. When the blade is to the rear, operate the steering levers / foot pedals in the opposite direction to when the blade is in the front.
- Move the steering levers / foot pedals slowly. Abrupt lever motion will cause the machine to jerk.

W-2235-0396

Turning

Right Turn

Figure 43

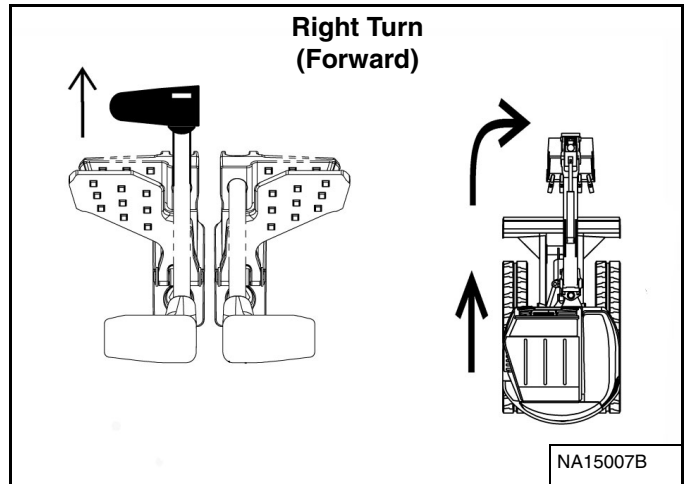

Push the left steering lever forward to turn right [Figure 43] while traveling forward.

Figure 44

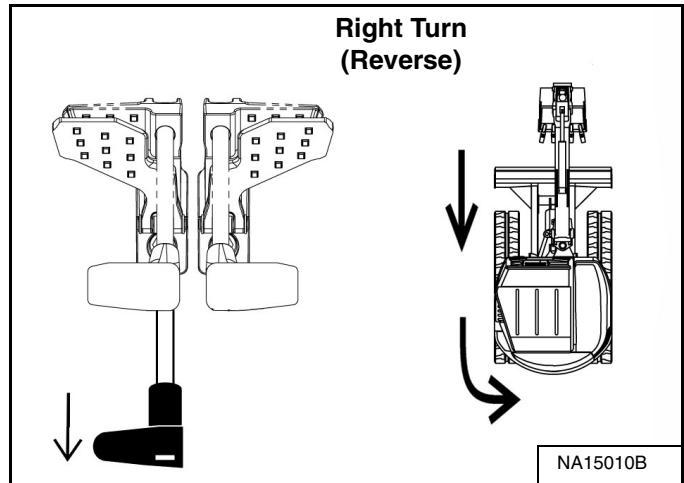

Pull the left steering lever backward to turn right while traveling backward [Figure 44]

TRAVEL CONTROLS (CONT'D)

Turning (Cont'd)

Counter-Rotation Right Turn

Figure 45

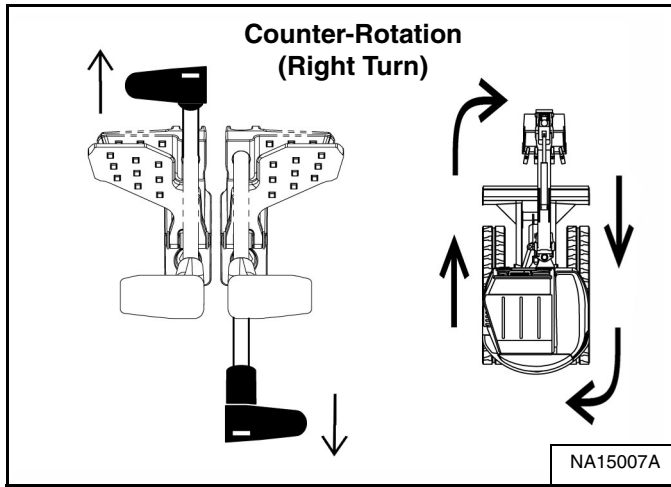

Push the left steering lever forward and pull the right steering lever backward [Figure 45].

Left Turn

Figure 46

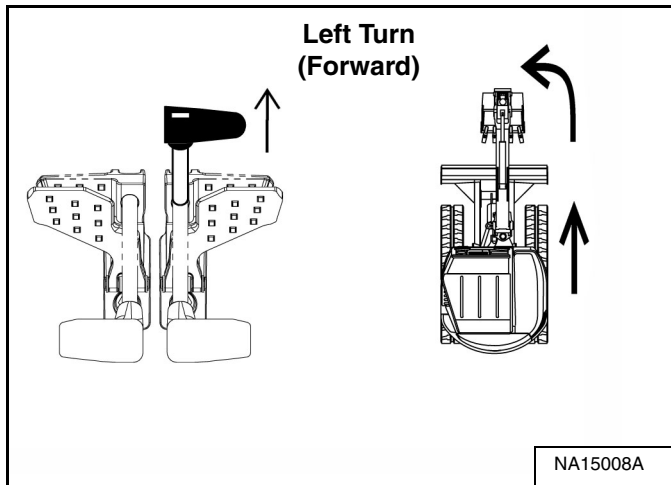

Push the right steering lever forward to turn left while traveling forward [Figure 46].

Figure 47

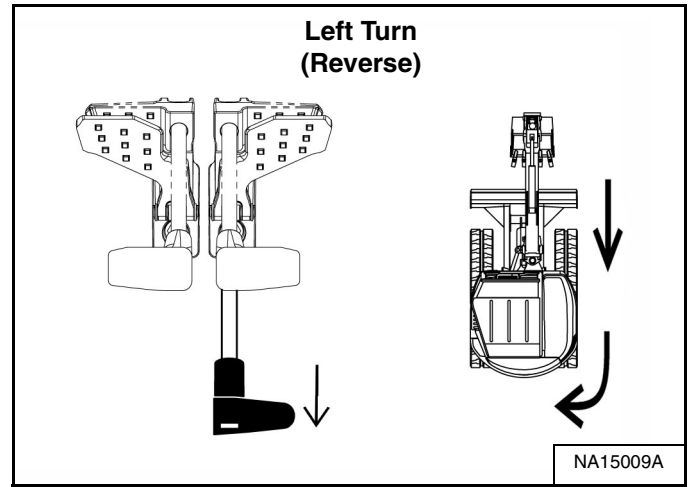

Pull the right steering lever backward to turn left while traveling backward [Figure 47].

Counter-Rotation Left Turn

Figure 48

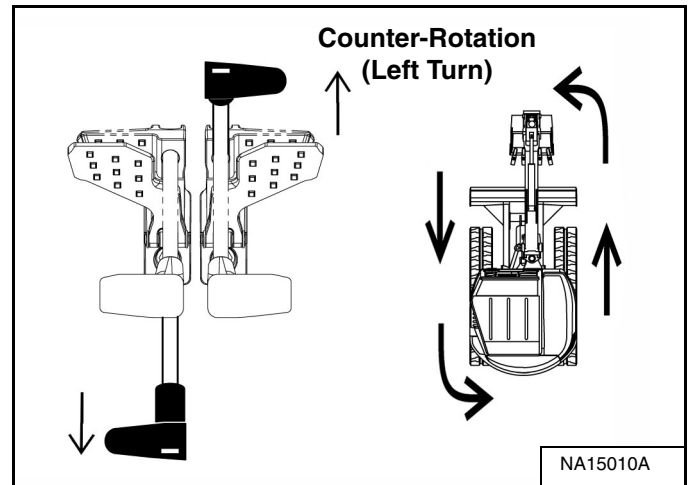

Push the right steering lever forward and pull the left steering lever backward [Figure 48].

HYDRAULIC CONTROLS

Description

Operate the work equipment (boom, arm, bucket, and upperstructure slew) with the left and right joysticks. These joysticks can be used in either an ISO Control Pattern or STANDARD Control Pattern.

ISO Control Pattern

Left Joystick

Figure 49



Figure 50

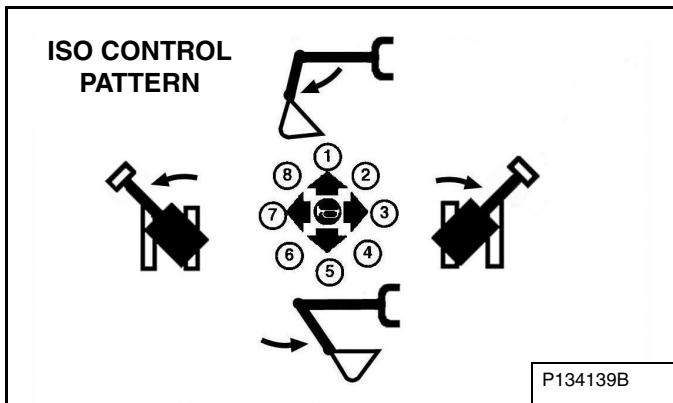

The left joystick [Figure 49] is used to operate the arm and slew the upperstructure [Figure 50].

1. Arm out.
2. Arm out and slew right.
3. Slew right.
4. Arm in and slew right.
5. Arm in.
6. Arm in and slew left.
7. Slew left.
8. Arm out and slew left.

Right Joystick

Figure 51



Figure 52

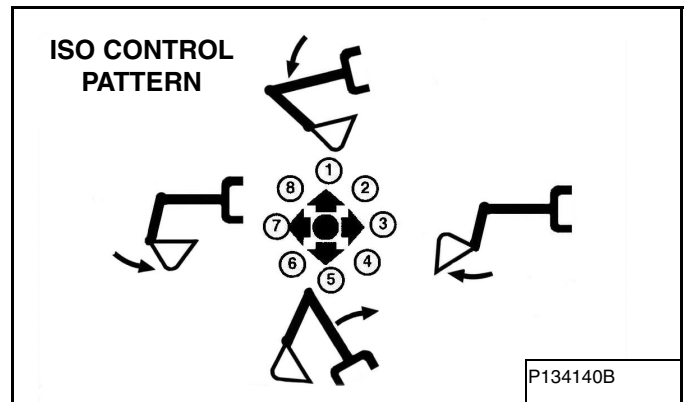

The right joystick [Figure 51] is used to operate the boom and bucket [Figure 52].

1. Boom lower.
2. Boom lower and bucket dump.
3. Bucket dump.
4. Boom raise and bucket dump.
5. Boom raise.
6. Boom raise and bucket curl.
7. Bucket curl.
8. Boom lower and bucket curl.

WARNING

AVOID INJURY OR DEATH

Before leaving the machine:

- Lower the work equipment to the ground.
- Lower the blade to the ground.
- Stop the engine and remove the key.
- Raise the control console.

W-2780-0109

HYDRAULIC CONTROLS (CONT'D)

STANDARD Control Pattern

Left Joystick

Figure 53



Figure 54

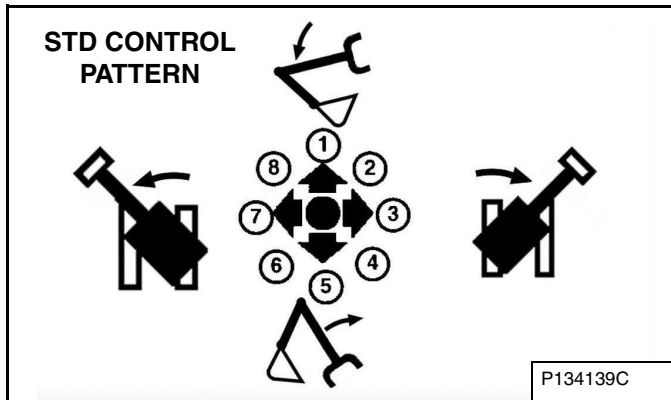

The left joystick [Figure 53] is used to operate the boom and slew the upperstructure [Figure 54].

1. Boom lower.
2. Boom lower and slew right.
3. Slew right.
4. Boom raise and slew right.
5. Boom raise.
6. Boom raise and slew left.
7. Slew left.
8. Boom lower and slew left.

Right Joystick

Figure 55



Figure 56

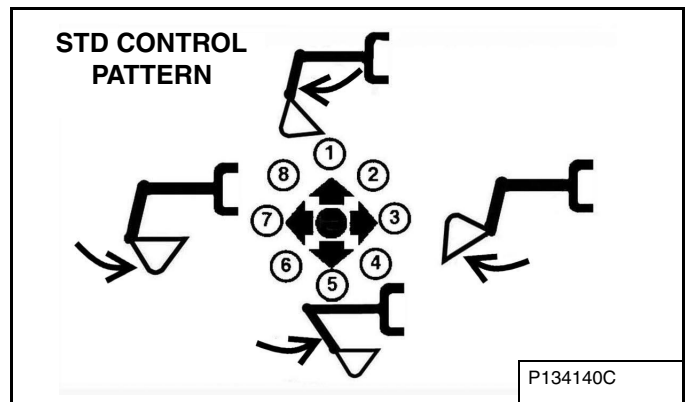

The right joystick [Figure 55] is used to operate the boom and bucket [Figure 56].

1. Arm out.
2. Arm out and bucket dump.
3. Bucket dump.
4. Arm in and bucket dump.
5. Arm in.
6. Arm in and bucket curl.
7. Bucket curl.
8. Arm out and bucket curl.

! WARNING

AVOID INJURY OR DEATH

Before leaving the machine:

- Lower the work equipment to the ground.
- Lower the blade to the ground.
- Stop the engine and remove the key.
- Raise the control console.

W-2780-0109

HYDRAULIC CONTROLS (CONT'D)

Quick Couplers

! WARNING

AVOID BURNS

Hydraulic fluid, tubes, fittings and quick couplers can get hot when running machine and attachments. Be careful when connecting and disconnecting quick couplers.

W-2220-0623

! WARNING

INJECTION HAZARD

Pressurized diesel fuel or hydraulic fluid can penetrate skin and eyes, causing serious injury or death.

Fluid leaks under pressure may not be visible. Use a piece of cardboard or wood to find leaks. DO NOT use your bare hand. Wear safety goggles. If fluid enters skin or eyes, get immediate medical attention from a doctor familiar with this injury.

W-2072-0824

Figure 57

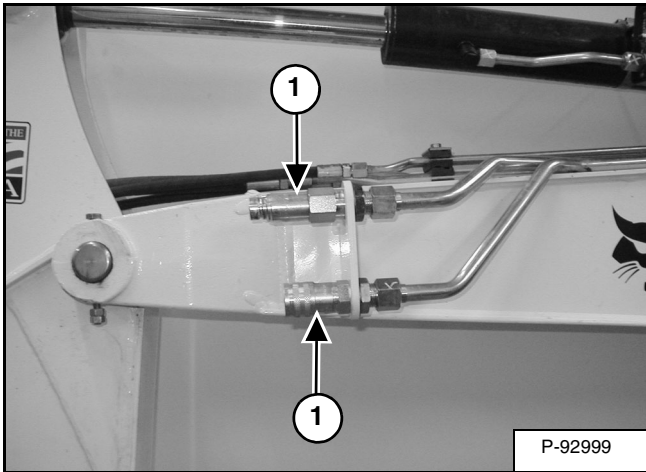

If equipped with auxiliary hydraulics, the excavator and attachments are supplied with flush faced couplers (Item 1) [Figure 57].

To Connect:

Remove any dirt or debris from the surface of both the male and female couplers, and from the outside diameter of the male coupler. Visually check the couplers for corroding, cracking, damage, or excessive wear. If any of these conditions exist, the coupler(s) (Item 1) [Figure 57] must be replaced.

Install the male coupler into the female coupler. Full connection is made when the ball release sleeve slides forward on the female coupler.

To Disconnect:

Figure 58

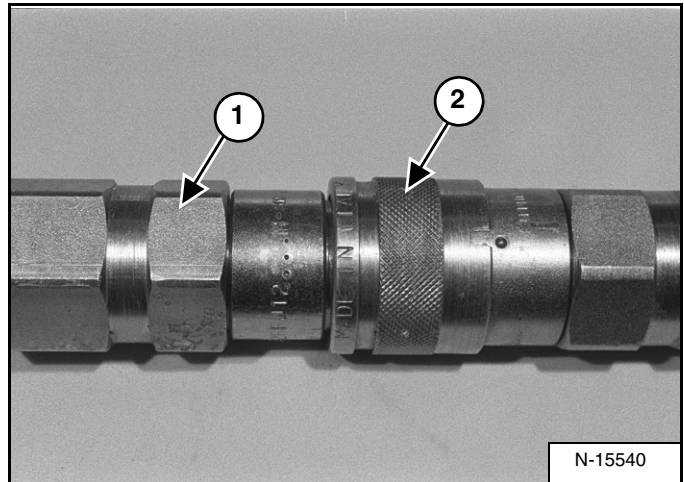

Hold the male coupler (Item 1). Retract the sleeve (Item 2) [Figure 58] on the female coupler until the couplers disconnect.

HYDRAULIC CONTROLS (CONT'D)

Selectable And Continuous Auxiliary Hydraulic Flow Description

The primary auxiliary hydraulics have Selectable Auxiliary Hydraulic Flow or Continuous Auxiliary Hydraulic Flow. This allows the operator to select a hydraulic flow that matches the attachment's hydraulic requirements.

If the auxiliary hydraulics are enabled when the engine is turned OFF, they will stay enabled when the engine is restarted. If Continuous flow was enabled at engine OFF, it will reset to Selectable flow.

NOTE: Use only approved attachments for your model excavator. Attachments are approved for each model of excavator based on various factors. Using unapproved attachments could cause damage to the attachment or to the excavator.

Activating Primary Auxiliary Hydraulics With Standard Instrument Panel

Figure 59

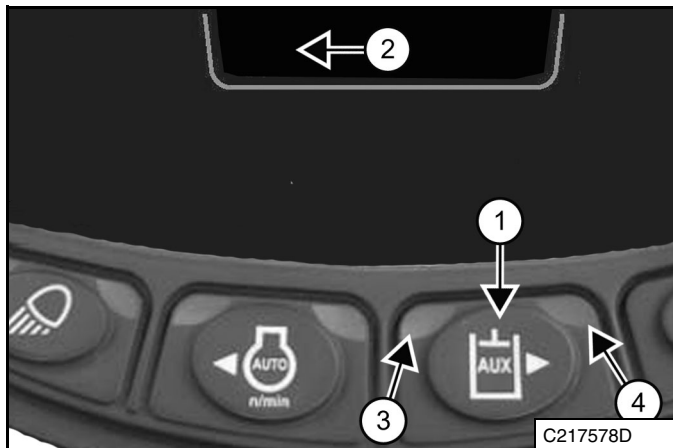

Selectable Flow Auxiliary Hydraulics - Press the AUX Hydraulics button (Item 1) [Figure 59]. A beep will sound each time the auxiliary button is pressed. The last selected auxiliary hydraulic flow (Mode 3, Mode 2, or Mode 1) will appear in the data display (Item 2) [Figure 59]. The left LED (Item 3) [Figure 59] will illuminate.

Press the AUX Hydraulics button (Item 1) [Figure 59] to scroll through the flow settings (3, 2, 1). The setting will appear in the data display (Item 2) [Figure 59]. Once the setting is selected, it will stay at that setting until a different auxiliary flow is selected by the operator, even after engine restart.

Continuous Flow Auxiliary Hydraulics - Press and hold the AUX Hydraulics button (Item 1) [Figure 59] for more than one second. The right LED (Item 4) [Figure 59] will illuminate. Press the AUX Hydraulics button (Item 1) [Figure 59] again to scroll through the flow settings (3, 2, 1).

Selectable Auxiliary Hydraulic Flow Settings For Selected Attachments

The auxiliary hydraulics can be set to Mode 3 (shown on display as 3^{AUX}), Mode 2 (2^{AUX}), Mode 1 (1^{AUX}), or OFF. Mode 3 allows maximum hydraulic flow, Mode 2 allows medium hydraulic flow, and Mode 1 allows low hydraulic flow.

AUX FLOW SETTING	FLOW	ATTACHMENTS
Mode 3 (3 ^{AUX})	Maximum	Breaker, Vibratory Plate Compactor, Auger
Mode 2 (2 ^{AUX})	Medium	Clamp, Grapple
Mode 1 (1 ^{AUX})	Low	Power Tilt, Hydra Tilt

HYDRAULIC CONTROLS (CONT'D)

Activating Primary Auxiliary Hydraulics With Deluxe Instrument Panel (Software Version 88.09 Or Below)

Figure 60



Selectable Flow Auxiliary Hydraulics - Press key 6 (Item 1) [Figure 60] to activate auxiliary hydraulics. Press key 6 (Item 1) [Figure 60] again to scroll through the flow settings (see table below).

Continuous Flow Auxiliary Hydraulics - Press and hold key 6 (Item 1) [Figure 60] for more than one second. The continuous flow icons below will illuminate. Press key 6 (Item 1) [Figure 60] to scroll through the flow settings (see table below).

ICON	DESCRIPTION
	Engine OFF - Auxiliary Hydraulics Pressure Release
	Engine Running - Auxiliary Hydraulics OFF
	Auxiliary Hydraulics - Maximum Flow - Continuous Flow Disabled
	Auxiliary Hydraulics - Medium Flow - Continuous Flow Disabled
	Auxiliary Hydraulics - Low Flow - Continuous Flow Disabled
	Auxiliary Hydraulics - Maximum Flow - Continuous Flow Enabled
	Auxiliary Hydraulics - Medium Flow - Continuous Flow Enabled
	Auxiliary Hydraulics - Low Flow - Continuous Flow Enabled

Activating Primary Auxiliary Hydraulics With Deluxe Instrument Panel (Software Version 88.10 Or Above)

Figure 61



NOTE: Updated deluxe panels have the Aux icon (Item 3) [Figure 61] on the Gauges screen.

Selectable Flow Auxiliary Hydraulics - Press key 6 (Item 1) [Figure 61] to activate auxiliary hydraulics.

Continuous Flow Auxiliary Hydraulics - Press and hold key 6 (Item 1) [Figure 61] for more than one second. The continuous flow icon will illuminate.

Setting Auxiliary Hydraulic Flow Rate

Figure 62



Press key 7 (Item 2) [Figure 61] to open the AUXILIARY SETTINGS screen and set auxiliary flow rate.

Adjust the flow rate percentages with keys 2 – 4 and 7 – 9. After changing a flow rate, press the save icon to save the setting.













HYDRAULIC CONTROLS (CONT'D)

Activating Primary Auxiliary Hydraulics With Deluxe Instrument Panel (Software Version 88.10 Or Above) (Cont'd)

On the AUXILIARY SETTINGS screen, press keys 1 or 6 to scroll through the settings [Figure 62]. See the table below for an explanation of the icons. Select the icon that corresponds to your attachment or select one of the Custom settings to save your own flow rates.

Press key 0 to return to the Gauges screen.

Press key 5 to return settings to the default setting.

ICON	DESCRIPTION
	Selectable Flow
	Continuous Flow
	Secondary Auxiliary
	Auger
	Cutter / Crusher
	Breaker
	Rotating Grapple
	Flail Mower
	Tilt Coupler
	Custom Setting 1
	Custom Setting 2
	Custom Setting 3

Operating Attachments With Primary Auxiliary Hydraulics

Figure 63

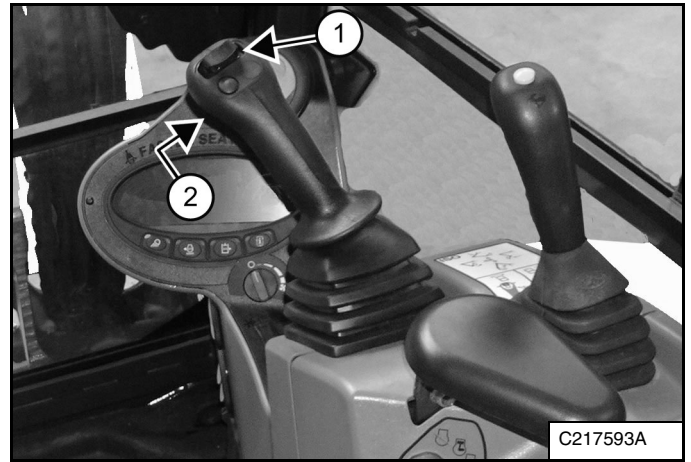

After activating auxiliary hydraulics and selecting Selectable or Continuous flow (See Activating Primary Auxiliary Hydraulics With Standard Instrument Panel on Page 53.), (See Activating Primary Auxiliary Hydraulics With Deluxe Instrument Panel (Software Version 88.09 Or Below) on Page 54.), or (See Activating Primary Auxiliary Hydraulics With Deluxe Instrument Panel (Software Version 88.10 Or Above) on Page 54.), operate the attachment as follows:

- Move the switch (Item 1) [Figure 63] on the right joystick to the right to supply hydraulic flow to the female coupler.
- Move the switch (Item 1) [Figure 63] to the left to supply hydraulic flow to the male coupler.
- Move the switch (Item 1) [Figure 63] halfway and the auxiliary functions will move at approximately one-half speed.
- Press the button (Item 2) [Figure 63] on the front of the handle to provide continuous flow to the female coupler.
- Press the switch (Item 1) to the left while pressing the button (Item 2) [Figure 63] on the front of the handle to provide continuous flow to the male coupler.
- Press the button (Item 2) [Figure 63] a second time to stop auxiliary flow to the quick couplers.

NOTE: Reverse flow can cause damage to some attachments. Use reverse flow with your attachment only if approved. See your attachment Operation & Maintenance Manual for detailed information.

HYDRAULIC CONTROLS (CONT'D)

Releasing Hydraulic Pressure In Excavator With Standard Instrument Panel

NOTE: Excavator engine must have recently been started to release hydraulic pressure.

Put the attachment flat on the ground.

Stop the engine and turn the key switch to ON.

NOTE: The left console must be fully lowered to release hydraulic pressure.

Figure 64

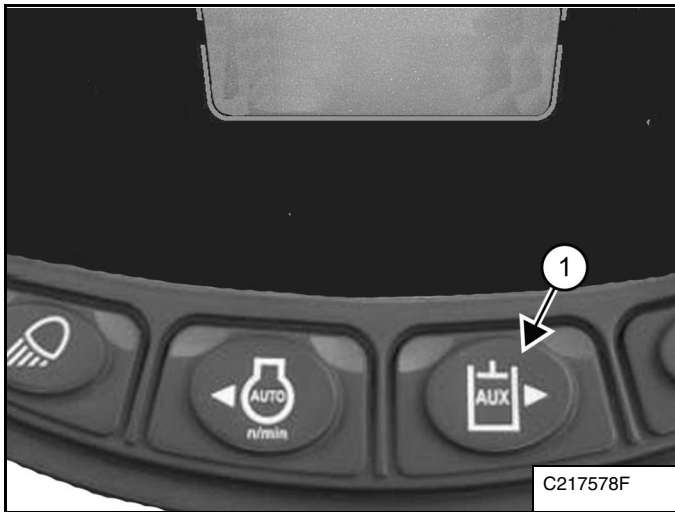

If the auxiliary hydraulics are disabled, press AUX Hydraulics button (Item 1) [Figure 64] and then move the switch (Item 1) [Figure 63] to the right and left several times.

If the auxiliary hydraulics are enabled, then move the switch (Item 1) [Figure 63] to the right and left several times.

Releasing Hydraulic Pressure In Excavator With Deluxe Instrument Panel

NOTE: Excavator engine must have recently been started to release hydraulic pressure.

Put the attachment flat on the ground.

Stop the engine and turn the start switch to ON.

NOTE: The left console must be fully lowered to release hydraulic pressure.

Figure 65



Press either Scroll button (Item 1) [Figure 65] until the above screen is visible.

Press key 6 [Figure 65] and the AUX PRESSURE RELEASE screen [Figure 66] will appear.

Figure 66



Press the ENTER button (Item 1) [Figure 66] to release auxiliary pressure in the excavator. An hour glass symbol will appear and when pressure is released, the screen will show *Auxiliary Hydraulic Pressure Release*.

HYDRAULIC CONTROLS (CONT'D)

Releasing Hydraulic Pressure In Attachments

Hydraulic pressure in the auxiliary hydraulic system can make it difficult to engage quick couplers to an attachment.

- Follow procedure to release hydraulic pressure in excavator.
- Connect male coupler from attachment to female coupler of excavator then repeat procedure above. This will release pressure in the attachment.
- Connect the female coupler from the attachment.

Secondary Auxiliary Hydraulics Location

Figure 67

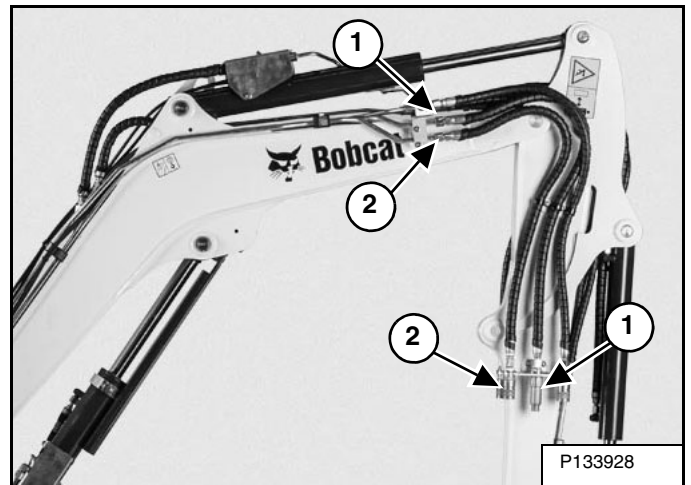

When machines are equipped with secondary auxiliary hydraulics, the second set of hydraulic couplers will be mounted on the right side of the arm or boom (Items 1 and 2) [Figure 67].

- Move the switch to the right to supply hydraulic flow to the male coupler.
- Move the switch halfway and the auxiliary functions will move at approximately one-half speed.

HYDRAULIC CONTROLS (CONT'D)

Operating Attachments With Secondary Auxiliary Hydraulics (Software Version 88.09 Or Below)

If your machine's software has been updated, (See Operating Attachments With Secondary Auxiliary Hydraulics (Software Version 88.10 Or Above) on Page 59.).

Figure 68

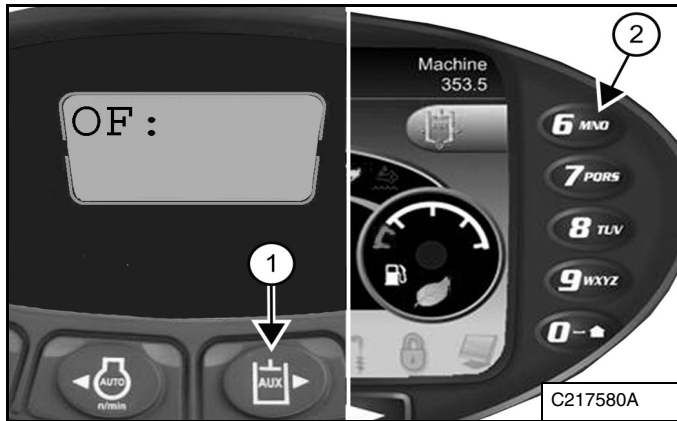

1. Activate auxiliary hydraulics.

- *Standard Instrument Panel:* Press the AUX Hydraulics button (Item 1) [Figure 68].
- *Deluxe Instrument Panel:* Press key 6 (Item 2) [Figure 68].

Figure 69

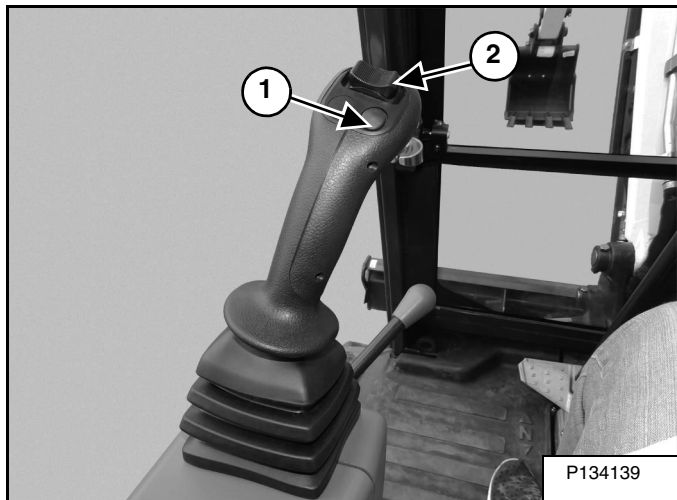

Press and hold the button (Item 1) [Figure 69] on the left joystick until a beep is heard to switch between the boom swing function and the secondary auxiliary hydraulics.

Figure 70

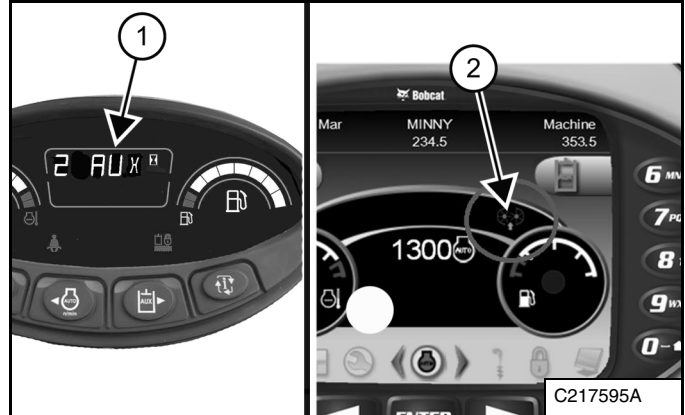

- *Standard Instrument Panel:* The display (Item 1) [Figure 70] will show 2 AUX when in the second auxiliary mode.
 - *Deluxe Instrument Panel:* The icon (Item 2) [Figure 70] will be illuminated when in the second auxiliary mode.
2. Operate the attachment as follows:
- Move the switch (Item 2) [Figure 69] on the left control lever to the left to supply hydraulic flow to the female coupler.
 - Move the switch (Item 2) [Figure 69] to the right to supply hydraulic flow to the male coupler.
 - Move the switch (Item 2) [Figure 69] halfway and the auxiliary functions will move at approximately one-half speed.

HYDRAULIC CONTROLS (CONT'D)

Operating Attachments With Secondary Auxiliary Hydraulics (Software Version 88.10 Or Above)

Figure 71



1. Activate auxiliary hydraulics.
- *Standard Instrument Panel:* Press the AUX Hydraulics button (Item 1) [Figure 71].
 - *Deluxe Instrument Panel:* Press key 6 (Item 2) [Figure 71].

Figure 72

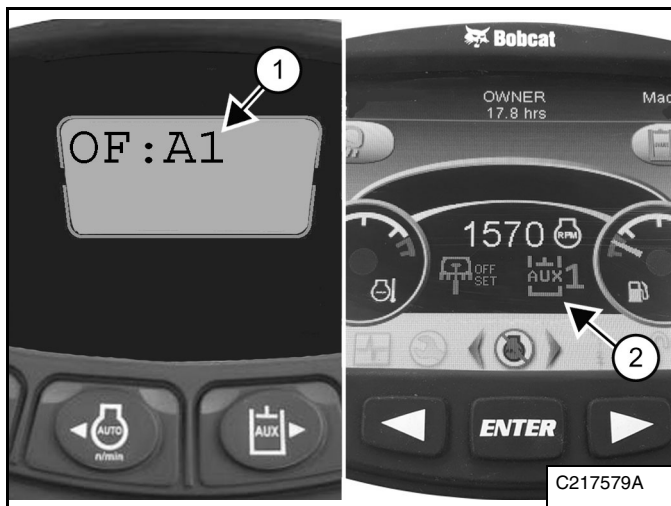

2. The display will indicate that the left joystick controls boom swing offset and the right joystick controls primary auxiliary hydraulics.
- *Standard Instrument Panel:* The display will show [OF:A1] (Item 1) [Figure 72].
 - *Deluxe Instrument Panel:* The display will show Offset and Aux1 icons (Item 2) [Figure 72].

Figure 73

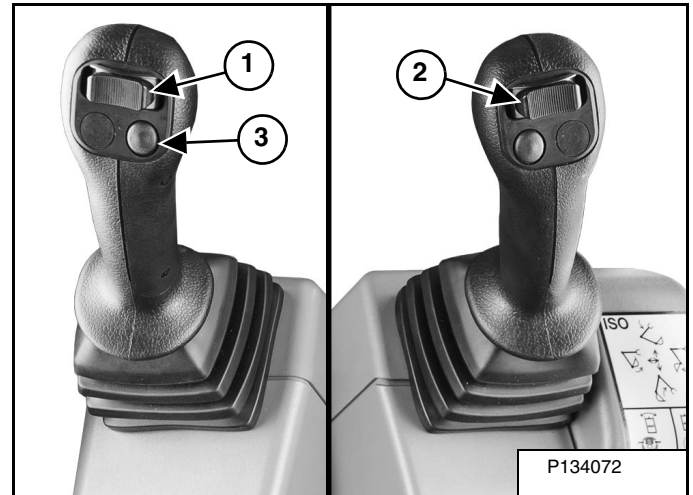

Press the left joystick button (Item 3) [Figure 73] until two beeps are heard to select Aux2.

NOTE: The joystick switches must be in the neutral position before you press a joystick button to change to a different auxiliary.

3. Operate the attachment as follows:
- Use the left joystick switch (Item 1) [Figure 73] to control the hydraulics indicated on the left side of the display panel (OF or Aux2).
 - Use the right joystick switch (Item 2) [Figure 73] to control the hydraulics indicated on the right side of the display panel (Aux1).

To set auxiliary hydraulics flow rate. (See Setting Auxiliary Hydraulic Flow Rate on Page 54.)

HYDRAULIC CONTROLS (CONT'D)

Releasing Secondary Auxiliary Hydraulic Pressure In Excavator

NOTE: Excavator engine must have recently been started to release hydraulic pressure.

1. Put the attachment flat on the ground.
2. Stop the engine and turn the key to ON.
3. Make sure left console is fully lowered.
4. Activate auxiliary hydraulics. (See Operating Attachments With Secondary Auxiliary Hydraulics (Software Version 88.09 Or Below) on Page 58.) (See Operating Attachments With Secondary Auxiliary Hydraulics (Software Version 88.10 Or Above) on Page 59.)
5. Activate secondary auxiliary hydraulics. (See Operating Attachments With Secondary Auxiliary Hydraulics (Software Version 88.09 Or Below) on Page 58.) (See Operating Attachments With Secondary Auxiliary Hydraulics (Software Version 88.10 Or Above) on Page 59.)
6. Move the left joystick switch (Item 2) **[Figure 69]** to the right and left several times to release pressure.

Releasing Secondary Auxiliary Hydraulic Pressure In Attachment

Hydraulic pressure in the auxiliary hydraulic system can make it difficult to engage quick couplers to an attachment.

- Follow procedure above to release pressure in excavator.
- Connect male coupler from attachment to female coupler of excavator then repeat procedure above. This will release pressure in the attachment.
- Connect the female coupler from the attachment.

OVERLOAD WARNING DEVICE

Description

NOTE: The excavator must be equipped with the optional boom load holding valve to install the overload warning device.

The overload warning device (if equipped), senses hydraulic pressure in the boom lift circuit. When the hydraulic pressure in the boom lift circuit reaches a predetermined pressure setting, a buzzer will sound that indicates an overload condition.

If the buzzer sounds, immediately move the arm closer to the excavator and lower the boom. Reduce the size of the load before attempting to re-lift the load.

Operation

Figure 74

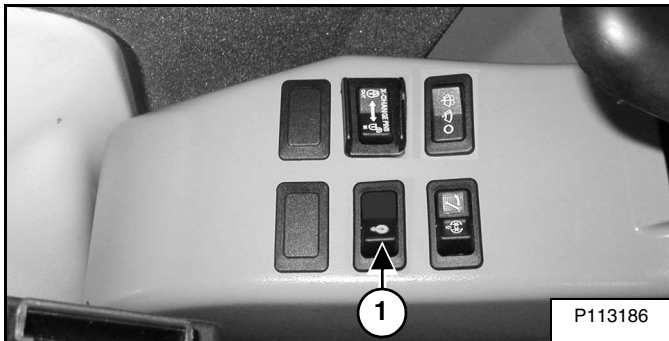

Figure 75



Press the switch (Item 1) [Figure 74] to the right to enable the Overload Warning Feature.

A buzzer will sound and the general warning icon (Item 1) [Figure 75] will illuminate when the boom is overloaded.

To disengage the overload warning feature, press the switch (Item 1) [Figure 74] to the left. The icon (Item 1) [Figure 75] will turn off when the overload warning feature is disabled.

BLADE CONTROL LEVER

Raising And Lowering Blade

Figure 76

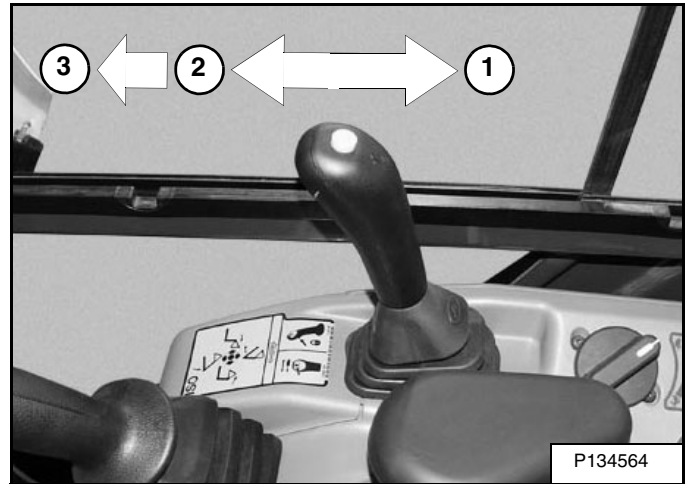

Pull the lever backward to raise the blade (Item 1) [Figure 76].

Push the lever forward to lower the blade (Item 2) [Figure 76].

Push the lever (Item 3) [Figure 76] forward until the lever is in the locked position to put the blade in the *float* position.

Pull the lever backward to unlock from the *float* position.

NOTE: Keep blade lowered for increased digging performance.

ENGINE SPEED CONTROL

Setting Engine Speed (RPM)

Figure 77

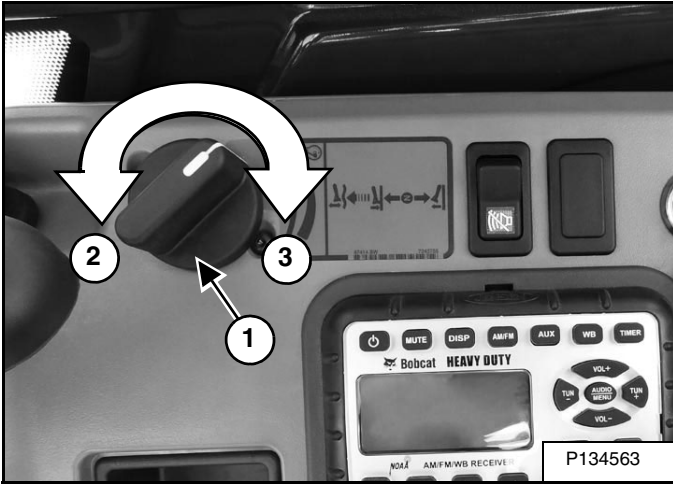

The engine speed control dial (Item 1) [Figure 77] controls engine rpm.

Rotate the engine speed control dial counterclockwise (Item 2) to reduce engine rpm. Rotate the engine speed control dial clockwise (Item 3) [Figure 77] to increase engine rpm.

NOTE: Auto idle feature is only available with the engine speed control dial (Item 1) [Figure 77]. (See Auto Idle Feature on Page 40.)

BOOM SWING

Operation

Figure 78

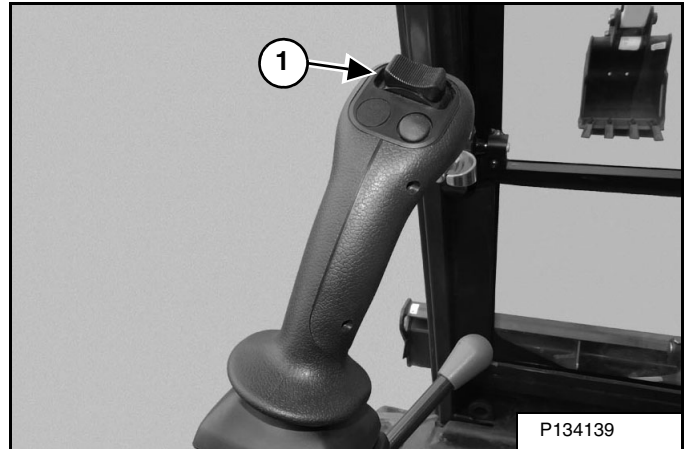

When no auxiliary hydraulics are enabled, control the boom swing with the left joystick switch (Item 1) [Figure 78]. Move the switch to the left to swing the boom to the left. Move the switch to the right to swing the boom to the right.

For instructions on operating the boom swing / auxiliary hydraulics, (See Operating Attachments With Secondary Auxiliary Hydraulics (Software Version 88.09 Or Below) on Page 58.) (See Operating Attachments With Secondary Auxiliary Hydraulics (Software Version 88.10 Or Above) on Page 59.)

Figure 79

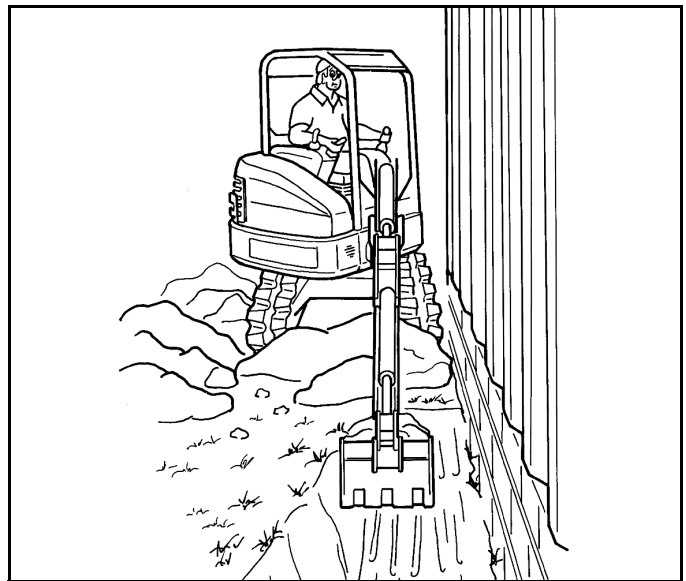

NOTE: The purpose of the boom swing is to offset the boom with respect to the upperstructure for digging close to a structure [Figure 79].

BOOM LOAD HOLDING VALVE

Description

The boom load holding valve (if equipped) will hold the boom in its current position in the event of hydraulic pressure loss.

! WARNING

AVOID INJURY OR DEATH

Do Not work or stand under raised work equipment, attachment, or implement.

W-2793-0123

Lowering The Boom With Accumulator Pressure

Place a container under the valve and hose end to contain hydraulic fluid. Enter the excavator and turn the key switch to the ON position or press the ENTER CODE Button (Keyless Panel), but do not start the engine. Move the joystick boom retract function to slowly lower the boom.

Lowering The Boom With NO Accumulator Pressure

Figure 80

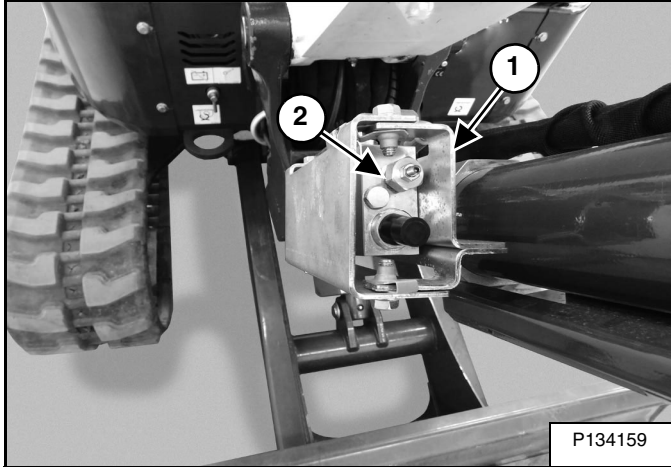

If the excavator is equipped with a boom load holding valve (Item 1) [Figure 80], it will be attached to the boom cylinder base end as shown.

Figure 81

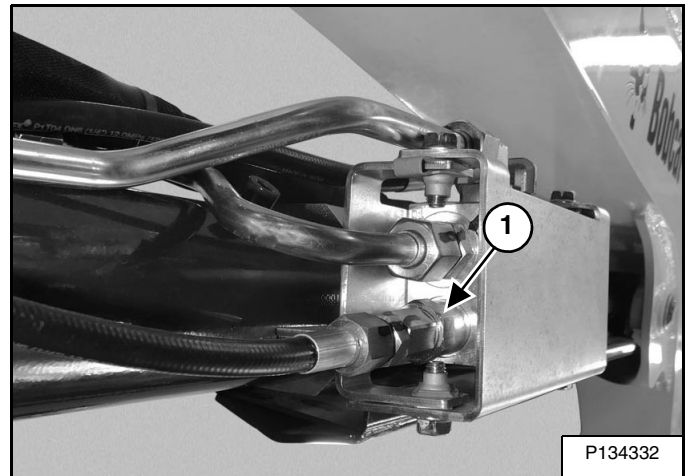

NOTE: DO NOT remove or adjust the port relief valves (Item 2) [Figure 80] and (Item 1) [Figure 81]. If a port relief valve has been tampered with, see your Bobcat dealer for service.

Figure 82

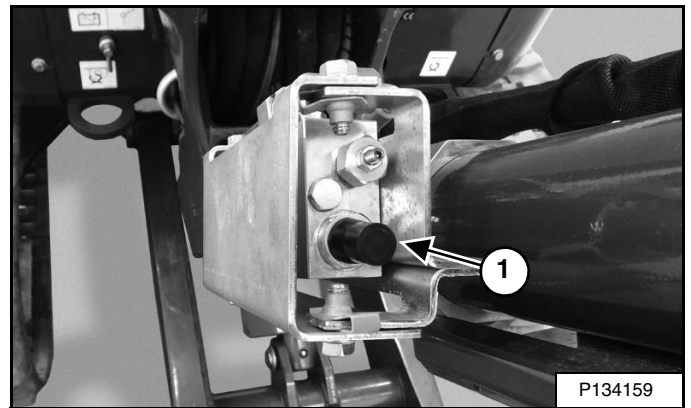

Remove the plastic protective cap (Item 1) [Figure 82] from the valve.

! WARNING

AVOID BURNS

Hydraulic fluid, tubes, fittings and quick couplers can get hot when running machine and attachments. Be careful when connecting and disconnecting quick couplers.

W-2220-0623

BOOM LOAD HOLDING VALVE (CONT'D)

Lowering The Boom With NO Accumulator Pressure (Cont'd)

Figure 83

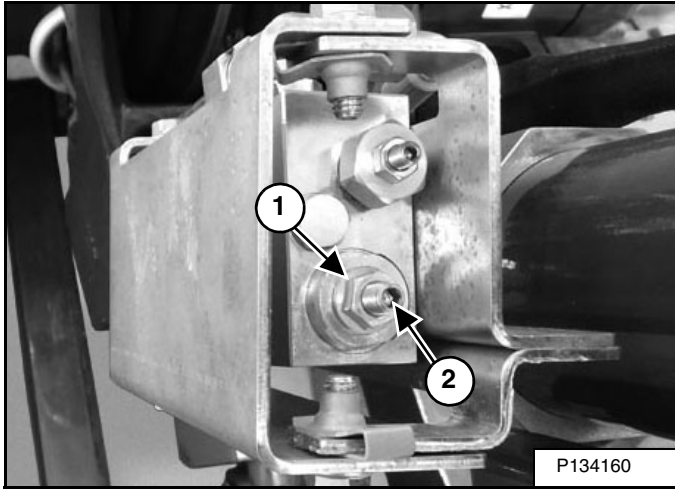

Remove the boom base end hose from the boom load holding valve. Place a container under the valve and base end hose to contain hydraulic fluid.

Loosen the locknut (Item 1). Install a hex wrench into the valve screw (Item 2) **[Figure 83]** and slowly rotate the screw clockwise 45° to 90° turn and allow the boom to lower to the ground.

After the boom is fully lowered, rotate the screw (Item 2) counterclockwise 45° to 90° turn and tighten the locknut (Item 1) **[Figure 83]**. Reinstall the base end hose.

ARM LOAD HOLDING VALVE

Description

The arm load holding valve (if equipped) will hold the arm in its current position in the event of hydraulic pressure loss.

! WARNING

AVOID INJURY OR DEATH

Do Not work or stand under raised work equipment, attachment, or implement.

W-2793-0123

Lowering The Arm With Accumulator Pressure

Place a container under the valve and hose end to contain hydraulic fluid. Enter the excavator and turn the key switch to the ON position or press the ENTER CODE Button (Keyless Panel), but do not start the engine. Move the joystick arm retract function to slowly lower the arm.

Lowering The Arm With NO Accumulator Pressure

Figure 84

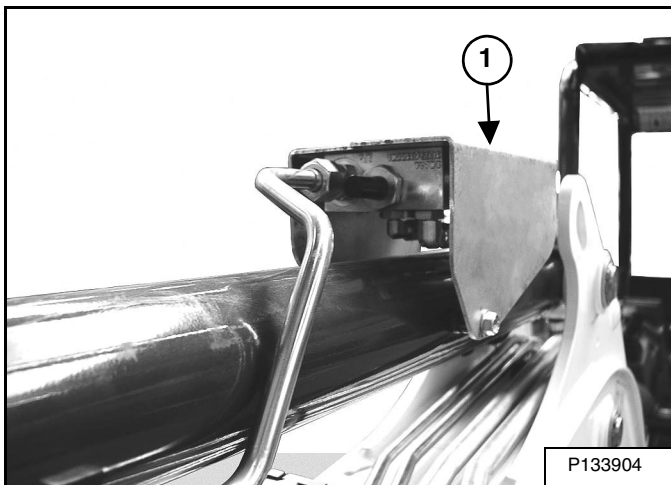

If the excavator is equipped with an arm load holding valve (Item 1) [Figure 84], it will be attached to the arm cylinder base end as shown.

Figure 85

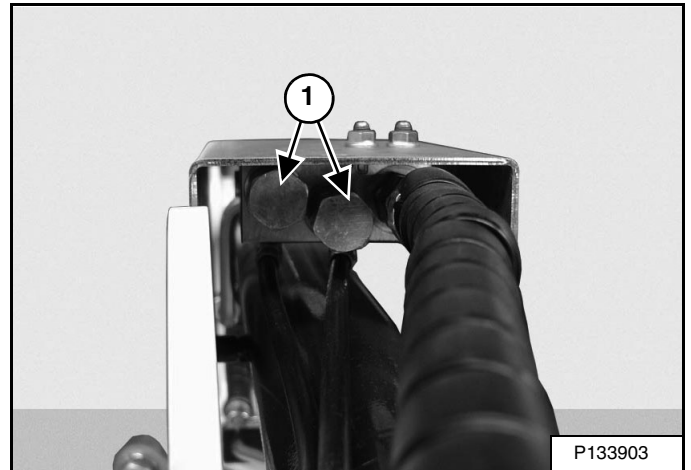

NOTE: DO NOT remove or adjust the two port relief valves (Item 1) [Figure 85]. If the port relief valves have been tampered with, see your Bobcat dealer for service.

Figure 86

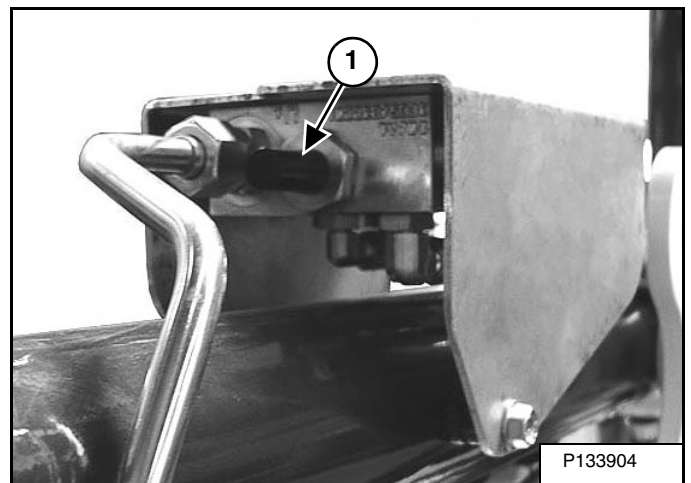

Remove the plastic protective cap (Item 1) [Figure 86] from the valve.

! WARNING

AVOID BURNS

Hydraulic fluid, tubes, fittings and quick couplers can get hot when running machine and attachments. Be careful when connecting and disconnecting quick couplers.

W-2220-0623

ARM LOAD HOLDING VALVE (CONT'D)

Lowering The Arm With NO Accumulator Pressure (Cont'd)

Figure 87

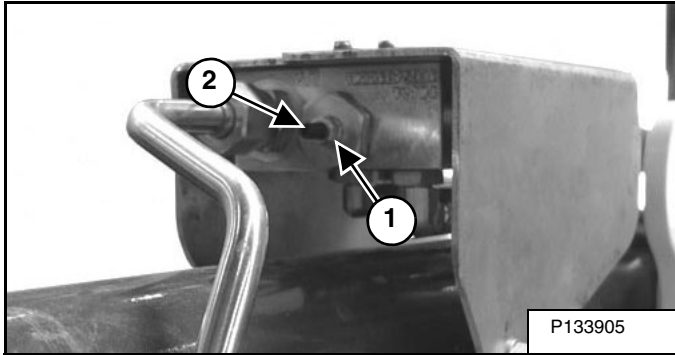

Remove the arm base end hose from the arm load holding valve. Place a container under the valve and base end hose to contain hydraulic fluid.

Loosen the locknut (Item 1). Install a hex wrench into the valve screw (Item 2) **[Figure 87]** and slowly rotate the screw clockwise 45° to 90° turn and allow the arm to lower.

After the arm is lowered, rotate the screw (Item 2) counterclockwise 45° to 90° turn and tighten the locknut (Item 1) **[Figure 87]**. Reinstall the base end hose.

DAILY INSPECTION

Daily Inspection And Maintenance

Maintenance work must be done at regular intervals. Failure to do so will result in excessive wear and early failures. The Service Schedule is a guide for correct maintenance of the Bobcat excavator.

Figure 88



The service schedule decal (Item 1) [Figure 88] is located inside the right cover.

A complete list of scheduled maintenance is also located in the Service Schedule. (See SERVICE SCHEDULE on Page 108.)

WARNING

INSUFFICIENT INSTRUCTIONS HAZARD

Untrained operators or failure to obey instructions can cause serious injury or death.

Operators must have adequate training and instruction before operating.

W-2001-0425

NOTE: Fluids such as engine oil, hydraulic fluid, coolant, etc. must be disposed of in an environmentally safe manner. Some regulations require that certain spills and leaks on the ground must be cleaned in a specific manner. See local, state, and federal regulations for correct disposal.

WARNING

INSUFFICIENT INSTRUCTIONS HAZARD

Untrained operators or failure to obey instructions can cause serious injury or death.

- Obey warnings and instructions in the Operation & Maintenance Manual, Operator's Handbook, and decals on machine.
- Obey warnings and instructions in the manuals when making repairs, adjustments, or servicing.
- Check for correct function after adjustments, repairs, or service.

W-2003-0425

Check the following items before each day of operation:

- Operator Canopy or Cab (ROPS / TOPS / FOPS) and mounting hardware.
- Check seat belt and mounting hardware. Replace seat belt if damaged.
- Check for damaged decals, replace as needed.
- Check control console lockout.
- Check Attachment Mounting System (if equipped) for damaged or loose parts.
- Check air cleaner and intake hoses / clamps.
- Check engine oil level and engine for leaks.
- Drain water from fuel filter.
- Check engine coolant level in coolant recovery tank and in radiator and check system for leaks.
- Check engine area for flammable materials.
- Check hydraulic fluid level and system for leaks.
- Check indicator lights for correct operation.
- Grease all pivot points.
- Check cylinder and attachment pivot points.
- Check the track tension.
- Repair broken and loose parts.
- Clean cab heater filter (if equipped).
- Check front horn and motion alarm (if equipped) for proper function.

DAILY INSPECTION (CONT'D)

Daily Inspection And Maintenance (Cont'd)

WARNING

GENERAL HAZARD

Failure to obey instructions can cause serious injury or death.

- Keep door / cover closed except for service.
- Keep engine clean of flammable material.
- Keep body, loose objects, and clothing away from electrical contacts, moving parts, hot parts, and exhaust.
- Do not use the machine in space with explosive dusts or gases or with flammable material near exhaust.
- Never use ether or starting fluid on diesel engine with glow plugs or air intake heater. Use only starting aids as approved by engine manufacturer.
- Leaking fluids under pressure can enter skin and cause serious injury.
- Battery acid causes severe burns; wear goggles. If acid contacts eyes, skin, or clothing, flush with water. For contact with eyes, flush and get medical attention.
- Battery makes flammable and explosive gas. Keep arcs, sparks, flames, and lighted tobacco away.
- For jump start, connect negative cable to the machine engine last (never at the battery). After jump start, remove negative connection at the engine first.
- Exhaust gases can kill. Always ventilate.

W-2782-0425

IMPORTANT

PRESSURE WASHING DECALS

- Never direct the stream at a low angle toward the decal that could damage the decal causing it to peel from the surface.
- Direct the stream at a 90 degree angle and at least 300 mm (12 in) from the decal. Wash from the center of the decal toward the edges.

I-2226-0910

PRE-STARTING PROCEDURE

Operation & Maintenance Manual And Operator's Handbook Locations

Figure 89

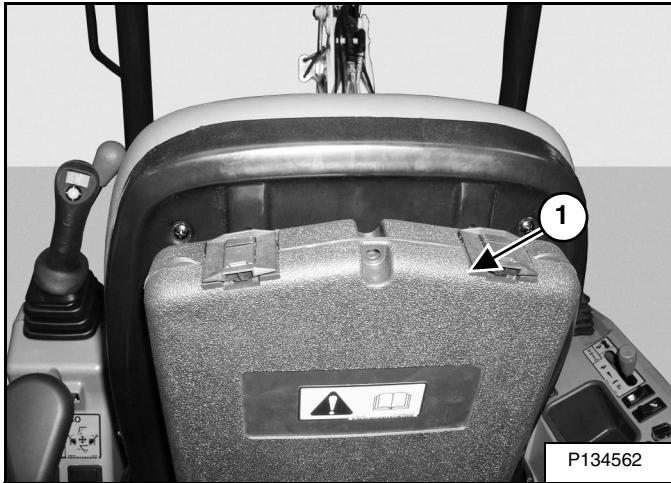
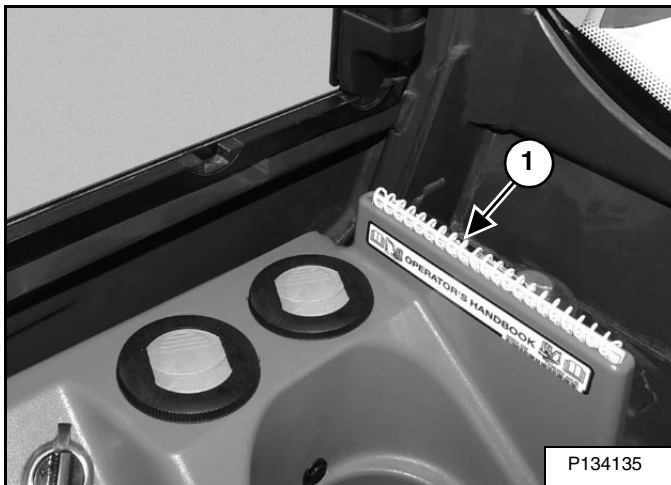

Figure 90



Read and understand the Operation & Maintenance Manual (Item 1) [Figure 89] (located inside the storage box on the back of the operator's seat) and the Operator's Handbook (Item 1) [Figure 90] before operating.

Entering The Excavator

Figure 91



Use the grab handles and tracks to enter the canopy / cab [Figure 91].

WARNING

INSUFFICIENT INSTRUCTIONS HAZARD

Untrained operators or failure to obey instructions can cause serious injury or death.

- Obey warnings and instructions in the Operation & Maintenance Manual, Operator's Handbook, and decals on machine.
- Obey warnings and instructions in the manuals when making repairs, adjustments, or servicing.
- Check for correct function after adjustments, repairs, or service.

W-2003-0425

PRE-STARTING PROCEDURE (CONT'D)

Seat Adjustment

Standard Seat

Figure 92

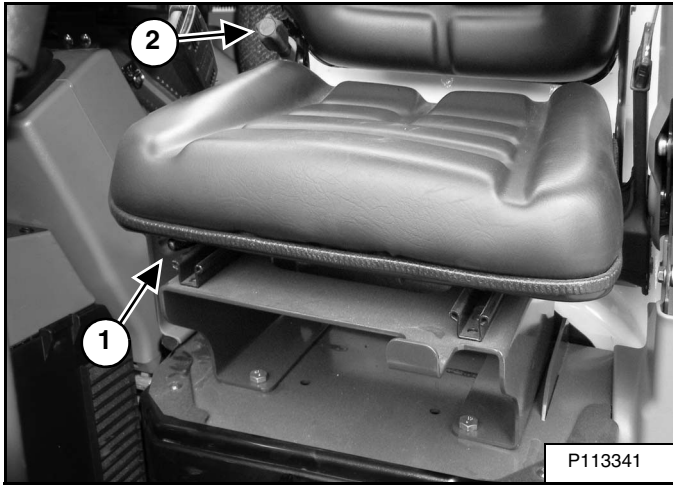

Release the seat lever (Item 1) [Figure 92] to adjust the seat forward or back.

Sit in the seat and turn the knob (Item 2) [Figure 92] to adjust the position of the back cushion.

Suspension Seat (If Equipped)

Figure 93

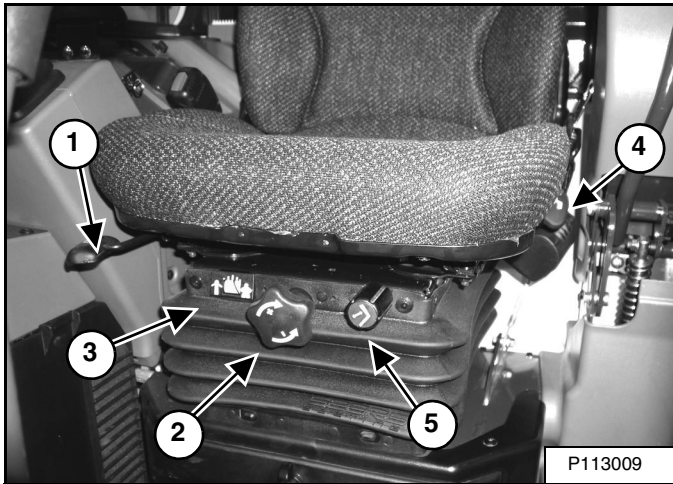

Release the seat lever (Item 1) [Figure 93] to adjust the seat forward or back.

Turn the handle (Item 2) to change the adjustment for operator weight. Turn the handle until the operator's weight is shown in the window (Item 3) [Figure 93].

Release the lever (Item 4) [Figure 93] to change the incline of the seat back.

Sit in the seat and turn the knob (Item 5) [Figure 93] to adjust the height of the seat.

Seat Belt

Figure 94



Fasten the seat belt [Figure 94].

STARTING THE ENGINE

Standard Instrument Panel - Key Start

! WARNING

AVOID INJURY OR DEATH

- Fasten seat belt, start and operate only from the operator's seat.
- Never wear loose clothing when working near machine.

W-2135-1108

Perform the PRE-STARTING PROCEDURE. (See PRE-STARTING PROCEDURE on Page 69.)

Figure 95

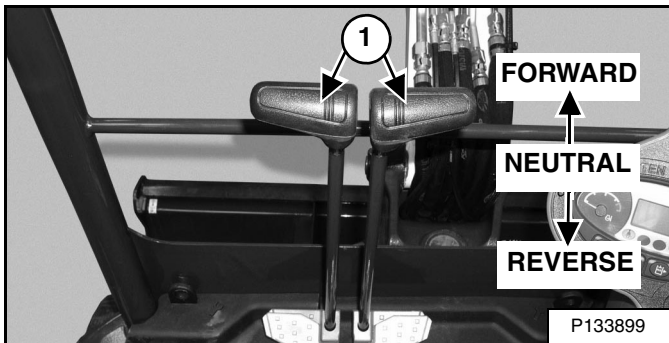

Put control levers (Item 1) [Figure 95] in the NEUTRAL position.

Figure 96

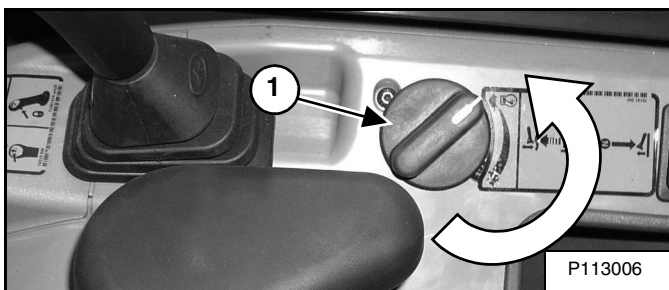

Turn the engine speed control dial (Item 1) [Figure 96] counterclockwise to low idle.

IMPORTANT

Do not engage the starter for longer than 15 seconds at a time. Longer use can damage the starter by overheating. Allow starter to cool for one minute before using starter again.

I-2034-0700

Figure 97

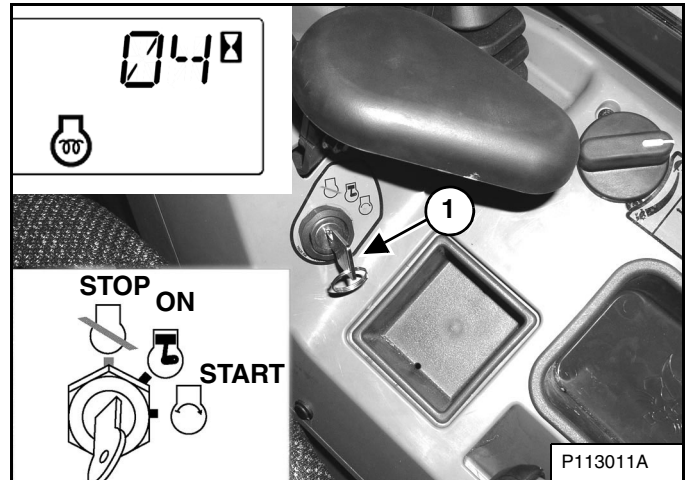

Turn the key (Item 1) [Figure 97] to the ON position. If preheating is required, the glow plugs will automatically cycle and the remaining preheat time (in seconds) will show in the data display screen (see inset). (Preheat icon will be ON).

Turn the key to START and release the key when the engine starts. It will return to the ON position [Figure 97].

Stop the engine if the warning lights and alarm do not go OFF. Check for the cause before starting the engine again.

Turn the key switch OFF to stop the engine.

! WARNING

AVOID INJURY OR DEATH

When an engine is running in an enclosed area, fresh air must be added to avoid concentration of exhaust fumes. If the engine is stationary, vent the exhaust outside. Exhaust fumes contain odorless, invisible gases which can kill without warning.

W-2050-0807

STARTING THE ENGINE (CONT'D)

Standard Instrument Panel - Keyless Start

! WARNING

AVOID INJURY OR DEATH

- Fasten seat belt, start and operate only from the operator's seat.
- Never wear loose clothing when working near machine.

W-2135-1108

Perform the PRE-STARTING PROCEDURE. (See PRE-STARTING PROCEDURE on Page 69.)

Figure 98

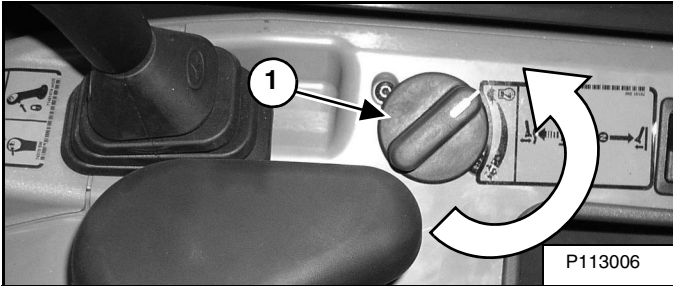

Turn the engine speed control dial (Item 1) [Figure 98] counterclockwise to low idle.

Figure 99

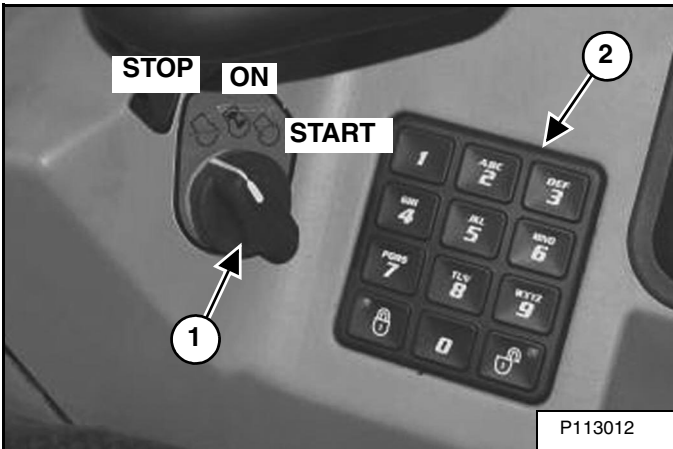

Turn the start switch (Item 1) [Figure 99] to ON. The indicator lights on the instrument panel will come ON briefly and the Instrument Panel / monitoring system will do a self test.

Use the keypad (Item 2) [Figure 99] to enter the password.

Figure 100

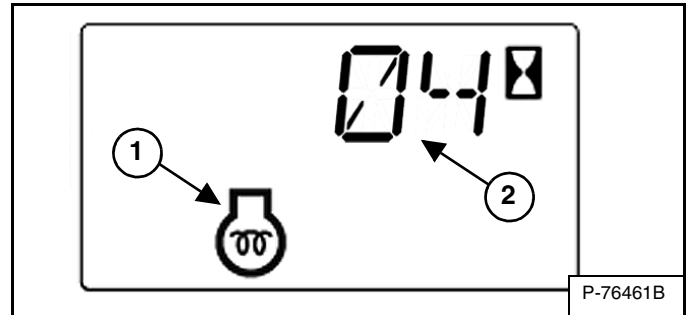

If preheating is required, the glow plugs will automatically cycle based on temperature. The engine preheat icon (Item 1) will be ON and the cycle time remaining (Item 2) [Figure 100] will be shown on the data display.

When the engine preheat icon goes OFF, turn the start switch (Item 1) [Figure 99] to START position and hold it until the engine starts. Release the switch (Item 1) [Figure 99] and it will return to the ON position.

IMPORTANT

Do not engage the starter for longer than 15 seconds at a time. Longer use can damage the starter by overheating. Allow starter to cool for one minute before using starter again.

I-2034-0700

Turn the start switch (Item 1) [Figure 99] to the STOP position to stop the engine.

Stop the engine if the warning lights and alarm do not go OFF.

Check for the cause before starting the engine again.

Password Lockout Feature

See Password Lockout Feature. (See Password Lockout Feature on Page 165.)

STARTING THE ENGINE (CONT'D)

Deluxe Instrument Panel - Keyless Start



FIRE AND EXPLOSION HAZARDS

Engines can have hot parts and hot exhaust gas that can cause serious injury or death.

- Keep flammable material away.
- DO NOT use machines in an atmosphere containing explosive dust or gases.

W-2051-0824

Perform the PRE-STARTING PROCEDURE. (See PRE-STARTING PROCEDURE on Page 69.)

Figure 101

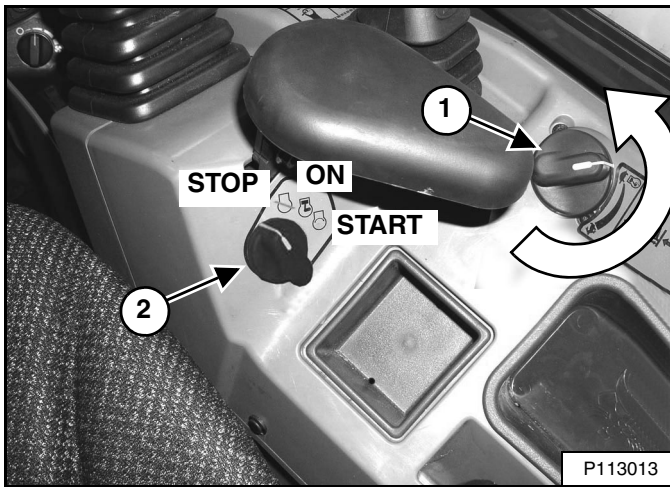

Set the engine speed control (Item 1) [Figure 101] to the low idle position.

NOTE: Excavators with a Deluxe Instrument Panel have a permanent, randomly generated Master Password set at the factory. Your excavator will also be assigned an Owner Password. Your dealer will provide you with this password. Change the owner password to one that you will easily remember to prevent unauthorized use of your excavator. (See Changing The Owner Password on Page 166.) Keep your password in a safe location for future needs.

NOTE: The Password Lockout feature can be used to allow starting of the excavator without a password. If unlocked, the start switch will start the machine without using a password. (See Password Lockout Feature on Page 165.)

Figure 102



Turn the start switch (Item 2) [Figure 101] to ON. The message [ENTER PASSWORD] will appear on the display screen if the deluxe instrument panel is locked. (If not locked, use the start switch without a password to start the engine.)

Use the numeric keypad (Item 1) [Figure 102] to enter the password.

Figure 103



If preheating is required, the glow plugs will automatically cycle and the engine preheat icon (Item 1) [Figure 103] and will be shown in the data display.

When the engine preheat icon goes OFF, turn the key switch to START (Item 2). Release the switch when the engine starts and allow it to return to the ON position (Item 2) [Figure 101].

Turn the start switch (Item 2) [Figure 101] to the STOP position to stop the engine.

Stop the engine if the warning lights and alarm do not go OFF.

Check for the cause before starting the engine again.

Password Lockout Feature

See Password Lockout Feature. (See Password Lockout Feature on Page 165.)

STARTING THE ENGINE (CONT'D)

Lowering The Control Console

Figure 104



Lower the control console [Figure 104].

NOTE: There is a control lock sensor in the left console which deactivates the hydraulic control levers (joysticks) and the traction drive system when the control console is raised. The console must be in the locked down position for the hydraulic control levers (joysticks) and traction system to operate.

NOTE: If the control lock sensor does not deactivate the control levers and traction system when console is raised, see your Bobcat dealer for service.

Warming The Hydraulic System

IMPORTANT

When the temperature is below -30°C (-20°F), hydrostatic oil must be warmed before starting. The hydrostatic system will not get enough oil at low temperatures and will be damaged. Park the machine in an area where the temperature will be above -18°C (0°F) if possible.

I-2007-0910

Let the engine run at least 5 minutes to warm the engine and hydraulic fluid before operating the excavator.

Cold Temperature Starting

! WARNING

EXPLOSION CAN CAUSE SERIOUS INJURY, DEATH OR SEVERE ENGINE DAMAGE
DO NOT use ether or starting fluid with glow plug or air intake heater systems.

W-2071-0415

If the temperature is below freezing, perform the following to make starting the engine easier:

- Replace the engine oil with the correct type and viscosity for the anticipated starting temperature. (See Engine Oil Chart on Page 125.)
- Make sure the battery is fully charged.
- Install an engine heater.

NOTE: If the battery is discharged (but not frozen) a booster battery can be used to jump start the excavator. (See Using A Booster Battery (Jump Starting) on Page 136.)

NOTE: The display screen on the instrument panel may not be at full intensity when the temperature is below -26°C (-15°F). The display screen may take 30 seconds to several minutes to warm up. All systems remain monitored even when the display screen is off.

MONITORING THE DISPLAY PANELS

Instrument Panel

Figure 105

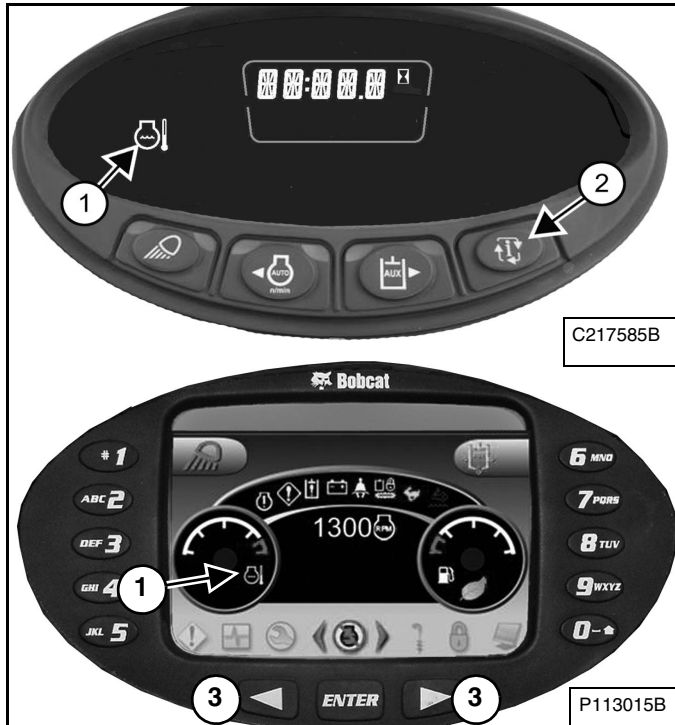

Frequently monitor the temperature and fuel gauges [Figure 105].

After the engine is running, frequently monitor the instrument panel [Figure 105] for machine condition.

The associated icon is displayed if there is an error condition.

EXAMPLE: Engine Coolant Temperature is High.

The Engine Coolant Temperature icon (Item 1) [Figure 105] is ON.

Press the Information button (Item 2) (Standard Panel) or press a scroll button (Item 3) [Figure 105] (Deluxe Panel) repeatedly to cycle the data display until the service code screen is displayed. One of the following SERVICE CODES is displayed.

- [M0810] Engine Coolant Temperature Too High
- [M0811] Engine Coolant Temperature Extremely High

Find the cause of the service code and correct before operating the excavator again. (See DIAGNOSTIC SERVICE CODES on Page 153.)

NOTE: The optional Deluxe Instrumentation Panel offers an additional view of service codes that includes a brief description. (See DIAGNOSTIC SERVICE CODES on Page 153.)

Warning And Shutdown

When a WARNING condition exists; the associated icon light is ON and the alarm sounds 3 beeps. If this condition is allowed to continue, there may be damage to the engine or hydraulic systems.

When a SHUTDOWN condition exists; the associated icon light is ON and the alarm sounds continuously. The monitoring system will automatically stop the engine in 15 seconds. The engine can be restarted to move or relocate the excavator.

The SHUTDOWN feature is associated with the following icons:

- General Warning
- Engine Malfunction
- Engine Coolant Temperature
- Hydraulic Fluid Temperature

STOPPING THE ENGINE AND LEAVING THE EXCAVATOR

Procedure

Figure 106



Stop the machine on level ground. Lower the work equipment and the blade to the ground [Figure 106].

Figure 107

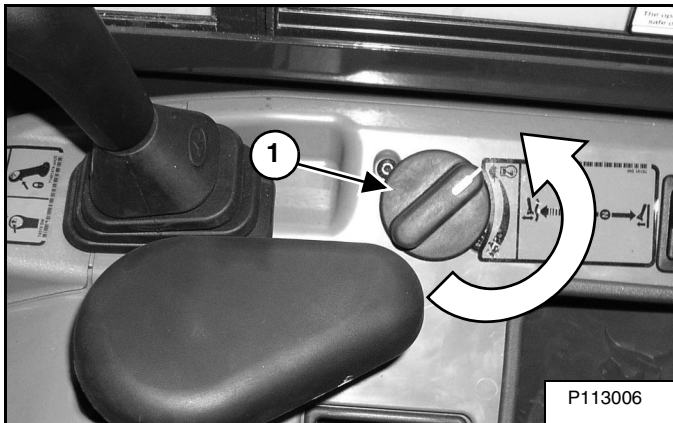

Rotate the engine speed control dial (Item 1) [Figure 107] counterclockwise to low idle.

Run the engine at idle speed for about 5 minutes to allow it to cool.

Figure 108

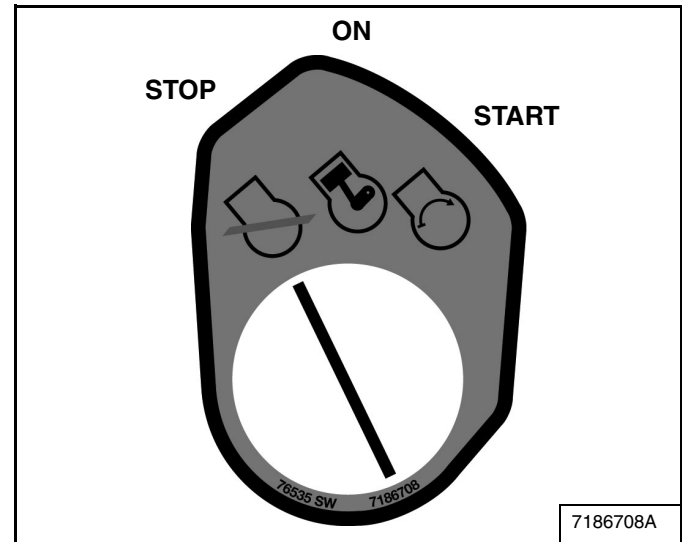

Turn the start switch to STOP [Figure 108].

Disconnect the seat belt. Remove the key from the switch (if equipped) to prevent operation of machine by unauthorized personnel. Raise the control console and exit the machine.

ATTACHMENTS

Installing And Removing The Attachment (Pin-On X-Change)

Installation

NOTE: Installation and removal of the bucket is shown. The procedure is the same for other attachments. Disconnect any hydraulic lines that are operated by hydraulic power before removing any attachments (breaker, auger, etc.).

! WARNING

MODIFICATION HAZARD

Unapproved attachments can cause serious injury or death.

Buckets and attachments for safe loads of specified densities are approved for each model. Never use attachments or buckets that are not approved by Bobcat.

W-2052-0824

! WARNING

Both hydraulic pins must be fully extended through the attachment mounting holes and locked with both retainer pins and clips. Failure to fully engage and lock hydraulic pins can allow attachment to come off and cause serious injury or death.

W-2507-0623

Figure 109

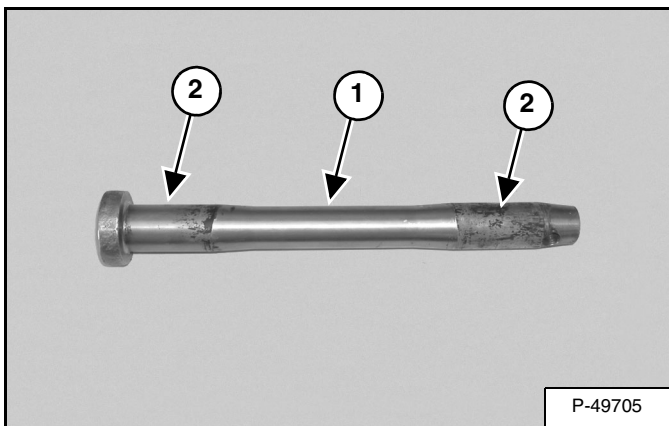

Inspect the pin (Item 1) [Figure 109] for wear or damage. Replace the pin as needed.

Apply a light coat of grease to the ends of the pin (Item 2) [Figure 109].

Figure 110

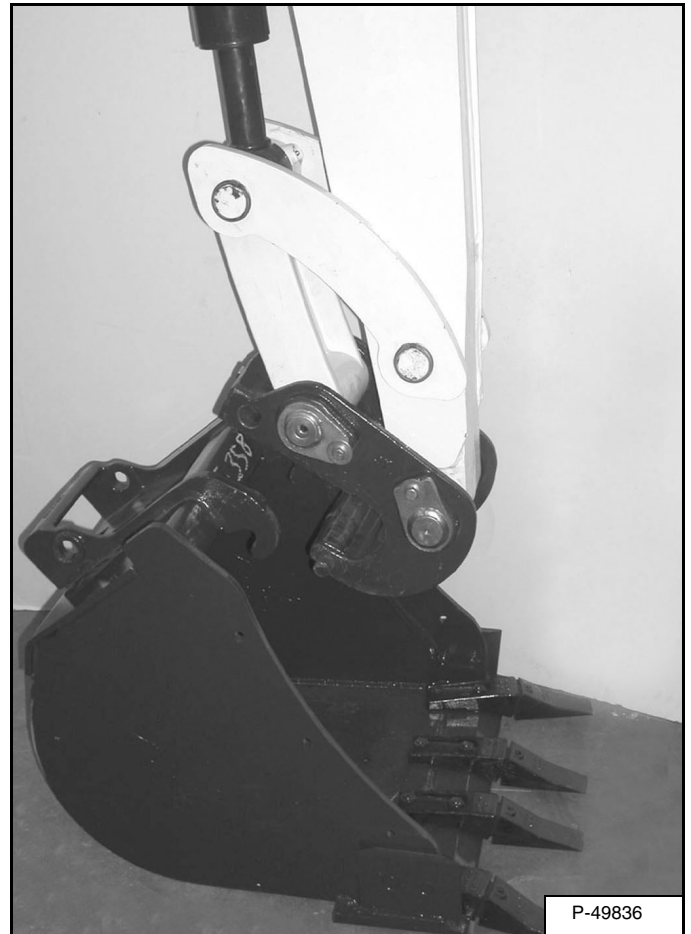

Start the engine and move the arm toward the bucket [Figure 110].

ATTACHMENTS (CONT'D)

Installing And Removing The Attachment (Pin-On X-Change) (Cont'd)

Installation (Cont'd)

Figure 111

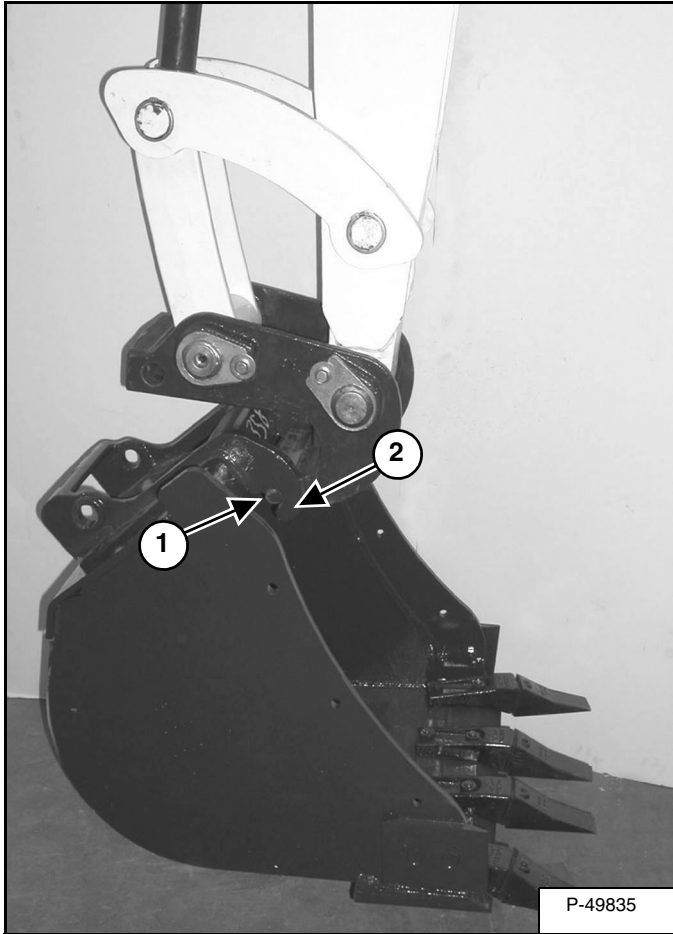

Raise the boom until the pins (Item 1) engage the hooks (Item 2) [Figure 111] on the bucket.

Figure 112

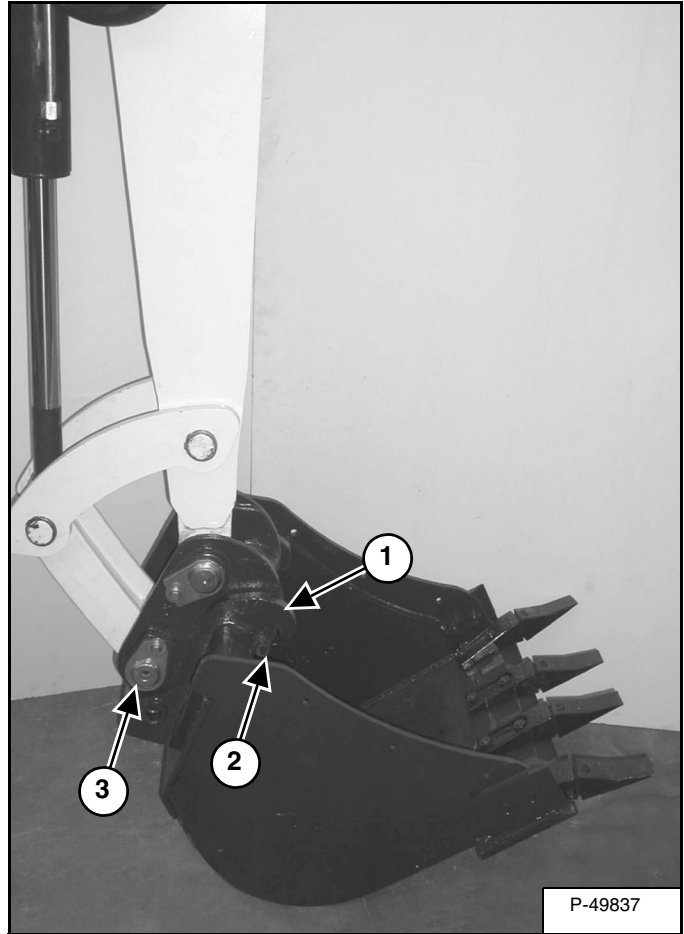

Raise the boom and extend the bucket cylinder until the X-Change contacts the attachment back [Figure 112].

With the arm vertical, lower the boom until the hooks (Item 1) of the bucket disengage the pins (Item 2) of the X-Change and the plate (Item 3) [Figure 112] fully engages in the bucket crossmember.



WARNING

IMPACT HAZARD

Grease fitting can come off with great force causing serious injury or death.

Keep bystanders away. Stand on side of boom or lift arm(s) opposite lube fitting when applying or removing tension from digging chain. Use correct fitting to prevent pressure from blowing it off.

W-2119-0824

ATTACHMENTS (CONT'D)

Installing And Removing The Attachment (Pin-On X-Change) (Cont'd)

Installation (Cont'd)

Figure 113

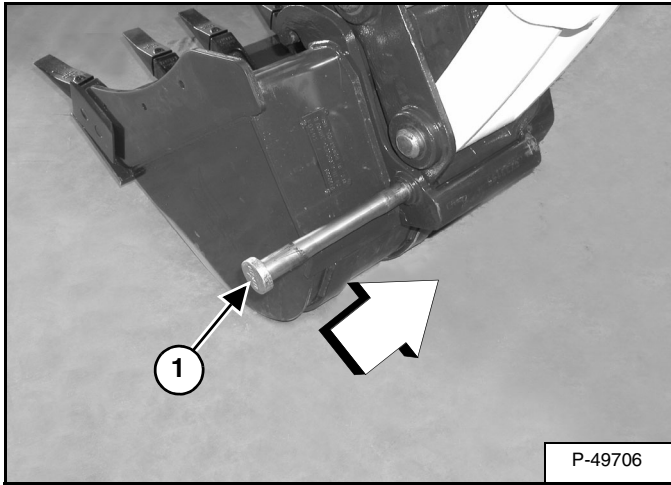

Stop the engine. Turn the start key to the ON position and move both hydraulic control levers to relieve hydraulic pressure.

Drive the pin (Item 1) **[Figure 113]** through the bucket mount and X-Change.

Figure 114

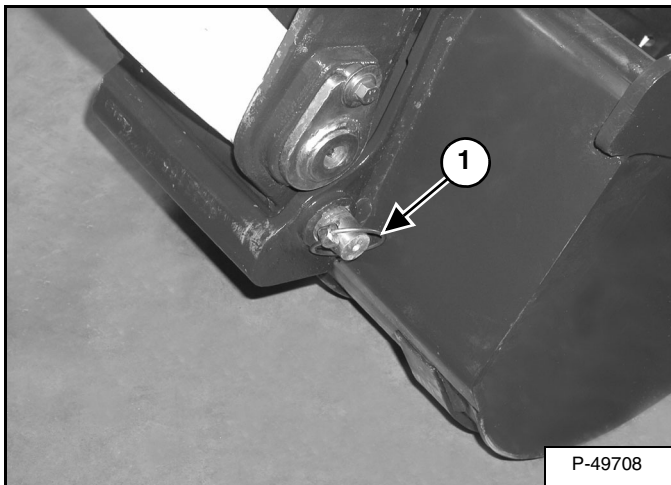

Install the retainer pin (Item 1) **[Figure 114]**.

Check for proper installation.

Lift the attachment and fully extend and retract the bucket cylinder.

ATTACHMENTS (CONT'D)

Installing And Removing The Attachment (Pin-On X-Change) (Cont'd)

Removal

Use the pin on X-Change when installing new attachments that are equipped with the pin on X-Change bracket.

NOTE: Removal and installation of the bucket is shown. The procedure is the same for other attachments. Disconnect any hydraulic lines that are operated by hydraulic power before removing any attachments (breaker, auger, etc.).

WARNING

MODIFICATION HAZARD

Unapproved attachments can cause serious injury or death.

Buckets and attachments for safe loads of specified densities are approved for each model. Never use attachments or buckets that are not approved by Bobcat.

W-2052-0824

Figure 115



Park the excavator on a flat level surface. Put the bucket on the ground [Figure 115].

With the engine off, turn the start key to the ON position and move both hydraulic control levers to relieve hydraulic pressure.

ATTACHMENTS (CONT'D)

Installing And Removing The Attachment (Pin-On X-Change) (Cont'd)

Removal (Cont'd)

Figure 116

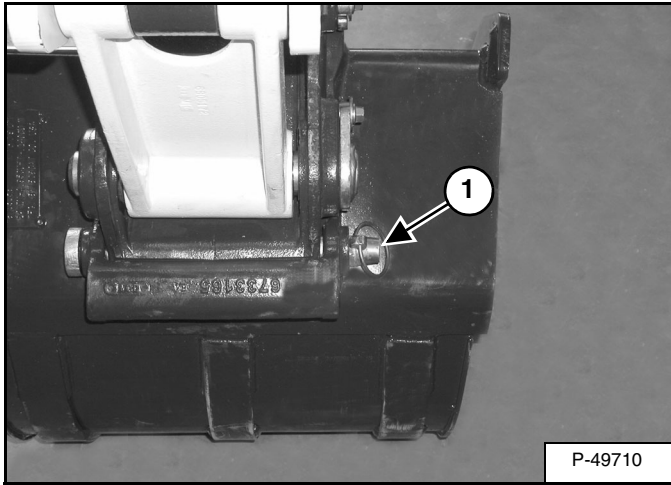

Remove the retainer pin (Item 1) [Figure 116].

Figure 117

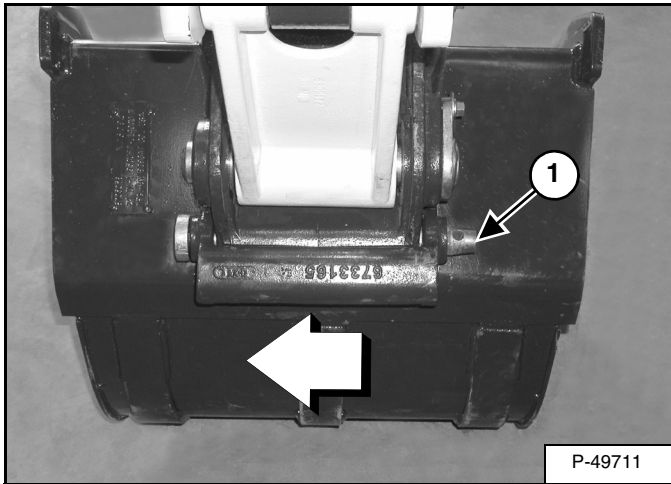

Drive the pin (Item 1) [Figure 117] out of the bucket and X-Change mount.



AVOID INJURY OR DEATH

Wear safety glasses to prevent eye injury when any of the following conditions exist:

- When fluids are under pressure.
- Flying debris or loose material is present.
- Engine is running.
- Tools are being used.

W-2019-0907

Figure 118

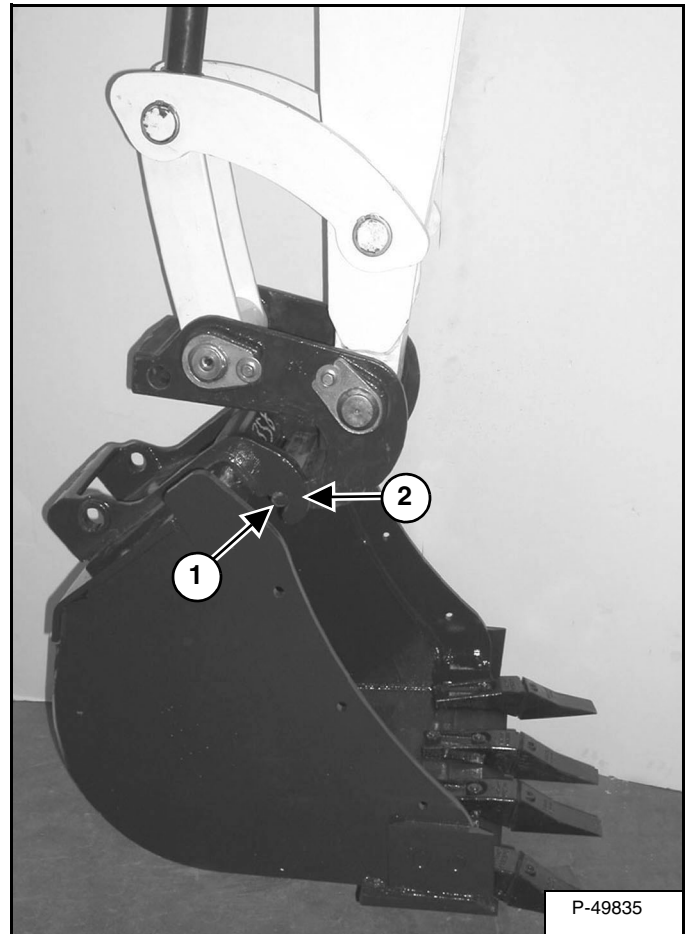

Start the engine, raise the boom approximately one foot and retract the bucket cylinder until the X-Change pins (Item 1) engage the hooks (Item 2) [Figure 118] on the bucket.

ATTACHMENTS (CONT'D)

Installing And Removing The Attachment (Pin-On X-Change) (Cont'd)

Removal (Cont'd)

Figure 119

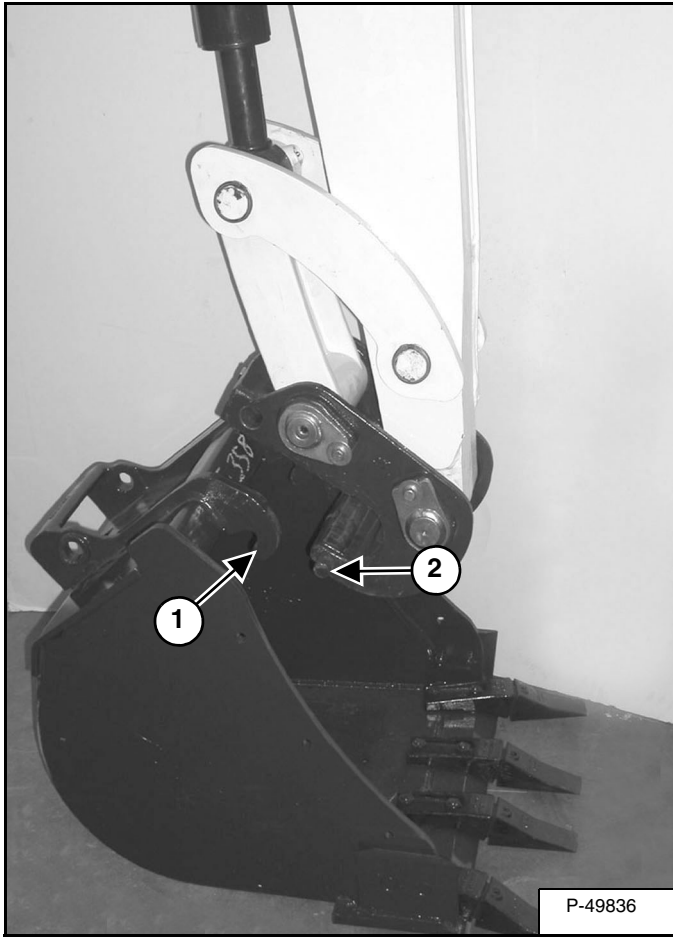

Fully retract the bucket cylinder and lower the boom and arm until the bucket is on the ground, and the X-Change pins (Item 1) are disengaged from the hooks (Item 2) [Figure 119].

Move the arm toward the excavator until the X-Change pins are clear of the bucket.

ATTACHMENTS (CONT'D)

Installing And Removing The Attachment (Hydraulic Pin Grabber Quick Coupler)

The type of quick coupler installed on the excavator may influence the excavator's rated lift capacity and the availability of attachments.

To determine the lift capacity changes, see the applicable lift capacity chart:

(See Rated Lift Capacity - Canopy With Heavy Counterweight on Page 172.), (See Rated Lift Capacity - Cab With Heavy Counterweight on Page 173.).

See your Bobcat dealer for a list of approved attachments for the type of quick coupler installed on the machine.

NOTE: Coupler equipped with the lifting device can only be used on machines where the overload warning device and the boom and arm load holding valves are installed. See your Bobcat dealer for available kits.

Installation

NOTE: Installation and removal of the bucket is shown. The procedure is the same for other attachments. Disconnect any hydraulic lines that are operated by hydraulic power before removing any attachments (breaker, auger, etc.).

Figure 120



Position the arm and quick coupler to the attachment [Figure 120].

NOTE: If equipped with a hydraulic clamp, fully retract the hydraulic clamp cylinder so the clamp is out of the way for installing the attachment.

WARNING

AVOID INJURY OR DEATH

Never use attachments or buckets which are not approved by Bobcat Company. Buckets and attachments for safe loads of specified densities are approved for each model. Unapproved attachments can cause injury or death.

W-2052-0907

WARNING

Keep all bystanders 6 m (20 ft) away from equipment when operating. Contact with moving parts, a trench cave-in or flying objects can cause injury or death.

W-2119-0910

Start the engine. (See PRE-STARTING PROCEDURE on Page 69.)

ATTACHMENTS (CONT'D)

Installing And Removing The Attachment (Hydraulic Pin Grabber Quick Coupler) (Cont'd)

Installation (Cont'd)

! WARNING

Keep all bystanders 6 m (20 ft) away from equipment when operating. Contact with moving parts, a trench cave-in or flying objects can cause injury or death.

W-2119-0910

Figure 121

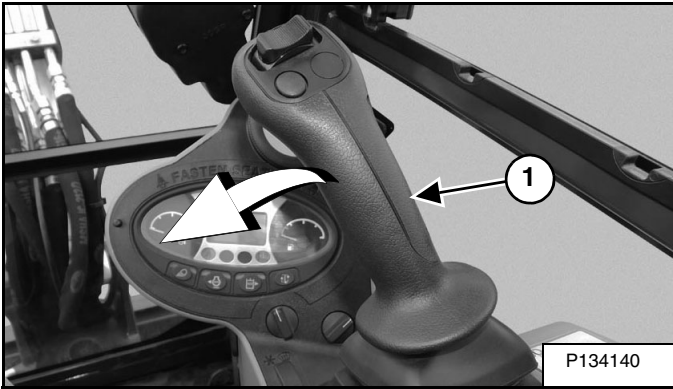
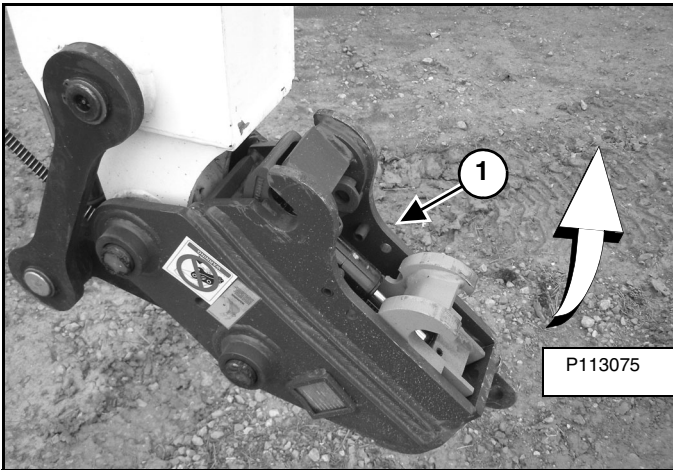
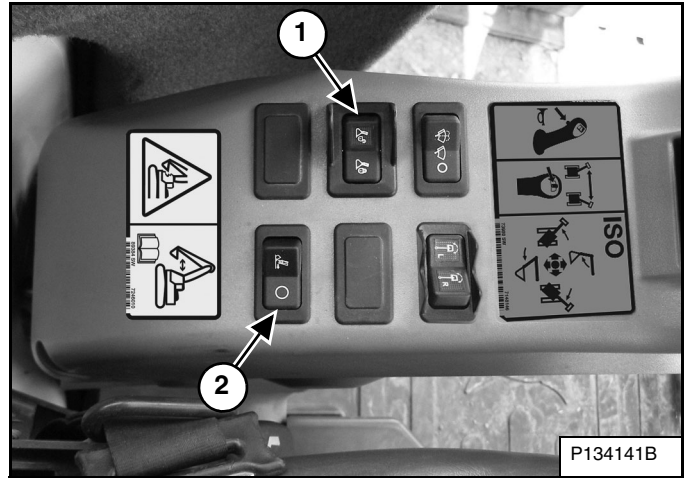

Figure 122



Move the right joystick (Item 1) [Figure 121] to the left (IN) to curl the coupler (Item 1) [Figure 122] fully in toward the cab.

Figure 123



Press the coupler ON / OFF switch (Item 1) [Figure 123] to the left (ON) position to enable the quick coupler feature. The switch will illuminate when in the ON position and a buzzer will sound.

While holding the right joystick (Item 1) [Figure 121] to the left (IN), press and release the INTENT switch (Item 2) [Figure 123] within five seconds after pressing the ON / OFF switch (Item 1) [Figure 123]. (The buzzer will continue to sound and the light (Item 1) [Figure 123] will stay ON.)

Figure 124

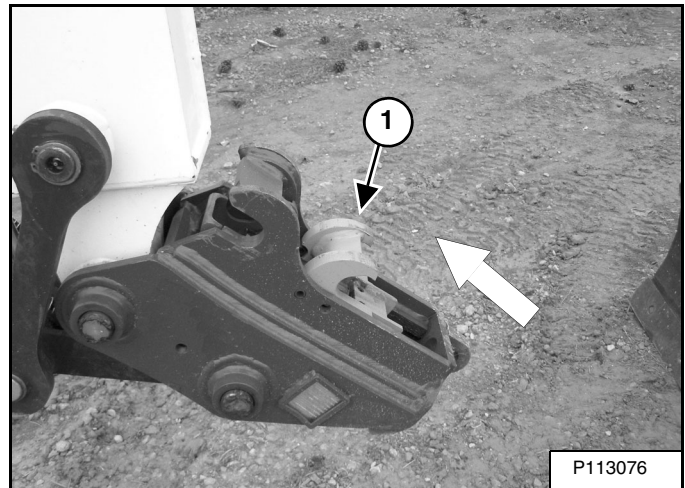

Continue holding the right joystick (Item 1) [Figure 121] to the left (IN) until the locking clasp (Item 1) [Figure 124] is fully retracted.

ATTACHMENTS (CONT'D)

Installing And Removing The Attachment (Hydraulic Pin Grabber Quick Coupler) (Cont'd)

Installation (Cont'd)

Figure 125

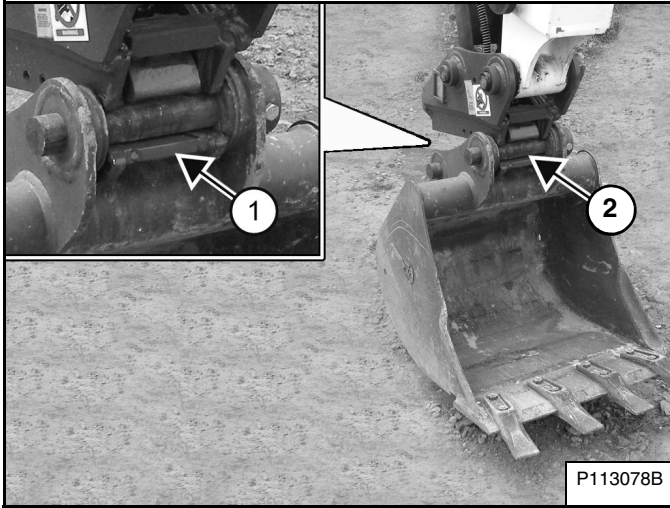

Roll the coupler out. Move the arm toward the attachment. Reposition the boom, arm and coupler until the coupler (Item 1) is positioned over the attachment pin (Item 2) [Figure 125]. Raise the attachment up slightly.

Figure 126

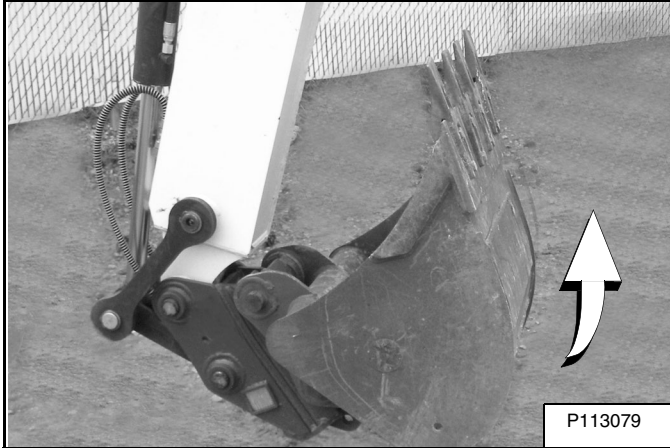

Curl the quick coupler in fully [Figure 126].

Press the coupler ON / OFF switch (Item 1) [Figure 123] to the right, (OFF) position. The switch light and buzzer will turn OFF.

Continue to curl the bucket in for an additional ten seconds to allow the locking clasp to move and lock to the bucket pins.

Figure 127

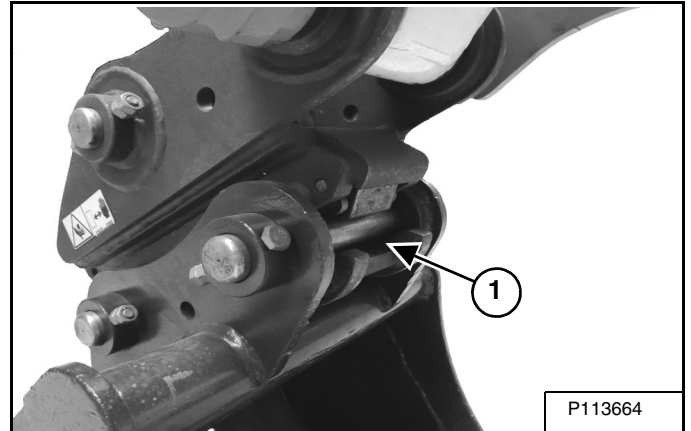

Visually check that the green locking clasp (Item 1) [Figure 127] is FULLY ENGAGED AND LOCKED, securely fastening the attachment to the coupler.

With the attachment as low to the ground as possible, curl the attachment out and in several times to ensure the attachment is secured to the coupler.

If the locking clasps do not engage in the locked position, see your Bobcat dealer for service.

Lower the attachment flat to the ground.

WARNING

AVOID INJURY OR DEATH

The quick coupler locking clasps / pins must be fully engaged and locked to the attachment pins. Failure to fully engage the locking clasps / pins can allow attachment to come off.

W-3024-0417

ATTACHMENTS (CONT'D)

Installing And Removing The Attachment (Hydraulic Pin Grabber Quick Coupler) (Cont'd)

Removal

NOTE: Removal and installation of the bucket is shown. The procedure is the same for other attachments. Disconnect any hydraulic lines that are operated by hydraulic power before removing any attachments (breaker, auger, etc.).

WARNING

Keep all bystanders 6 m (20 ft) away from equipment when operating. Contact with moving parts, a trench cave-in or flying objects can cause injury or death.

W-2119-0910

Enter the excavator and start the engine. (See PRE-STARTING PROCEDURE on Page 69.)

Figure 128

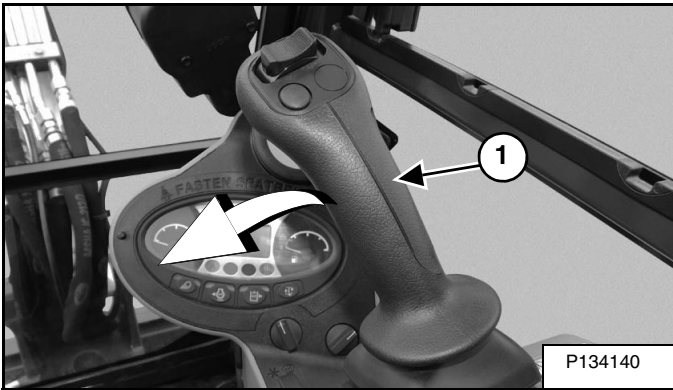
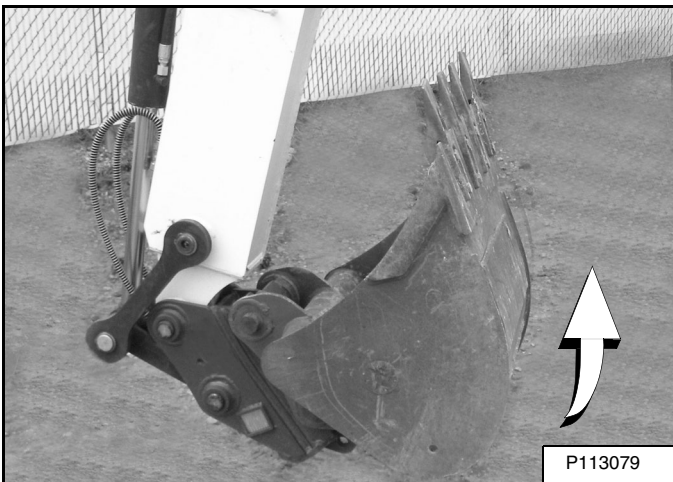

Figure 129



Raise the attachment slightly off of the ground.

Move the right joystick (Item 1) [Figure 128] to the left (IN) to curl the coupler (Item 1) [Figure 129] fully in toward the cab.

Figure 130

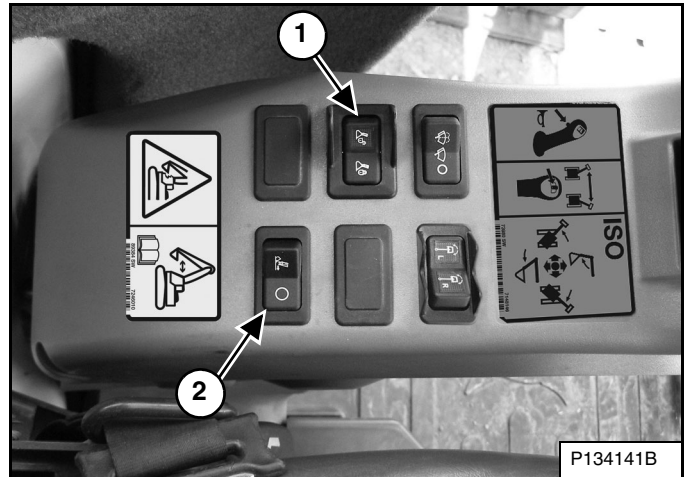

Press the coupler ON / OFF switch (Item 1) [Figure 130] to the left (ON) position to enable the quick coupler feature. The switch will illuminate when in the ON position and a buzzer will sound.

While holding the right joystick (Item 1) [Figure 128] to the left (IN), press and release the INTENT switch (Item 2) [Figure 130] within five seconds after pressing the ON / OFF switch (Item 1) [Figure 130]. (The buzzer will continue to sound and the light (Item 1) [Figure 130] will stay ON.)

Figure 131

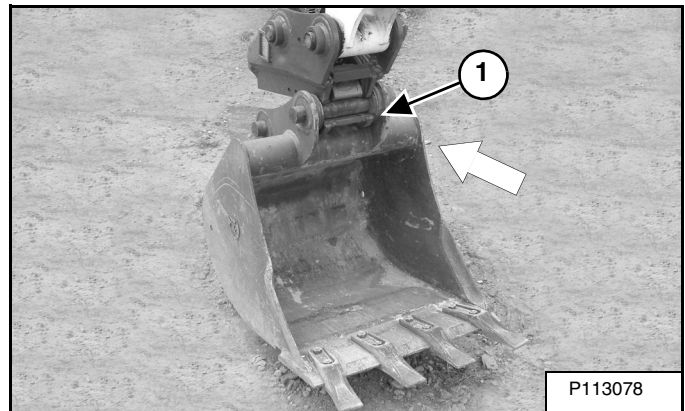

Continue holding the right joystick (Item 1) [Figure 128] to the left (IN) until the green locking clasp (Item 1) [Figure 128] retracts and will unlock the attachment from the quick coupler.

ATTACHMENTS (CONT'D)

Installing And Removing The Attachment (Hydraulic Pin Grabber Quick Coupler) (Cont'd)

Removal (Cont'd)

Figure 132

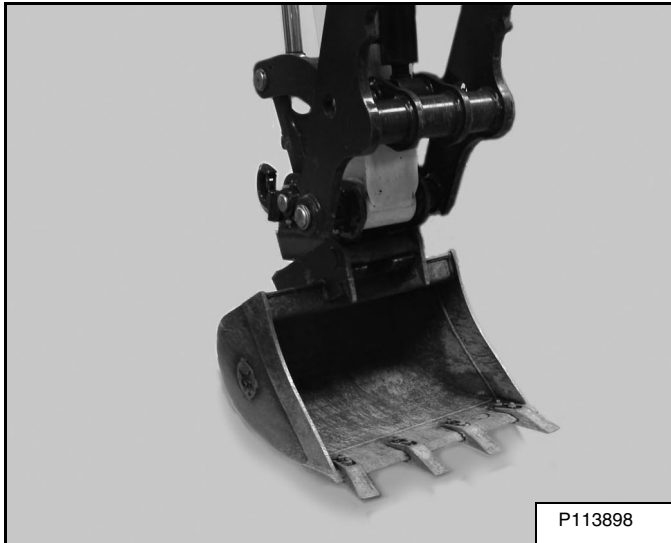

With the attachment slightly off the ground, roll the quick coupler back until the coupler starts to disengage from the attachment [Figure 132].

Figure 133

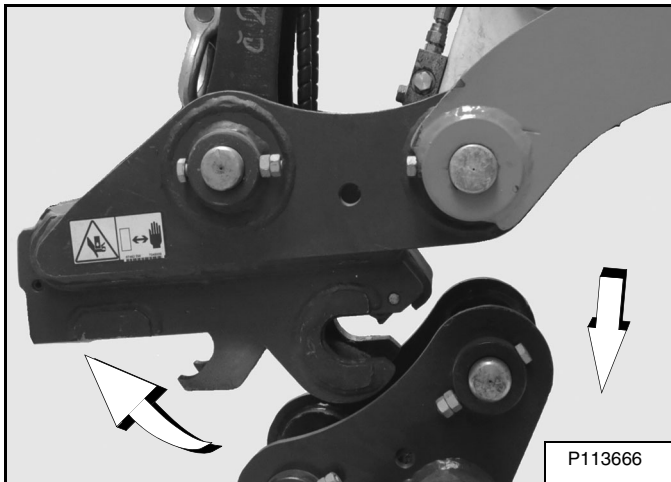

Roll the quick coupler back fully.

Lower the boom and arm until the attachment is on the ground and the quick coupler is disengaged from the attachment pins.

Move the arm away from the excavator until the quick coupler is clear of the attachment [Figure 133].

Figure 134

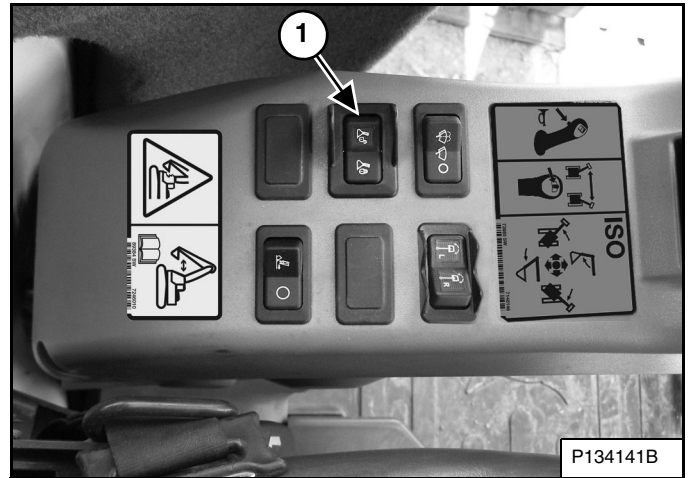

Press the coupler ON / OFF switch (Item 1) [Figure 134] to the right, (OFF) position. The switch light and buzzer will turn OFF.

OPERATING PROCEDURE

Inspect The Work Area

Before beginning operation, inspect the work area for unsafe conditions.

Look for sharp drop-offs or rough terrain. Have underground utility lines (gas, electrical, water, sewer, irrigation, etc.) located and marked. Work slowly in areas of underground utilities.

Remove objects or other construction material that could damage the excavator or cause personal injury.

Always check ground conditions before starting your work:

- Look for signs of instability such as cracks or settlement.
- Be aware of weather conditions that can affect ground stability.
- Check for adequate traction if working on a slope.

Basic Operating Instructions

When operating on a public road or highway, always follow local, state, and federal regulations. For example: A slow moving vehicle (SMV) sign, or direction signals may be required.

Run the engine at low idle speed to warm the engine and hydraulic system before operating the excavator.

IMPORTANT

Machines warmed up with moderate engine speed and light load have longer life.

I-2015-0284

New operators must operate the excavator in an open area without bystanders. Operate the controls until the excavator can be handled at an efficient and safe rate for all conditions of the work area.

Operating Near An Edge Or Water

Keep the excavator as far back from the edge as possible and the excavator tracks perpendicular to the edge so that if part of the edge collapses, the excavator can be moved back.

Always move the excavator back at any indication the edge may be unstable.

Lowering The Work Equipment (Engine STOPPED)

The hydraulic joysticks control the movement of the boom, arm, bucket and upperstructure slew functions.

The console must be in the locked down position, and the key switch in the ON position.

Use the control lever to lower the boom.

Figure 135



The joystick lock switch disengages the hydraulic control functions from the joysticks when the console are raised [Figure 135].

NOTE: If the engine stops, the boom / bucket (attachments) can be lowered to the ground using hydraulic pressure in the accumulator.

The control console must be in the locked down position, and the key switch in the ON position.

Use the control lever to lower the boom.

Lower the control console to engage the hydraulic control functions of the joysticks [Figure 135].

OPERATING PROCEDURE (CONT'D)

Object Handling With The Lifting Device

The excavator must be equipped with the optional lift eye link (Item 1) [Figure 137]. See your Bobcat dealer for available kits.

! WARNING

AVOID INJURY OR DEATH

- Do not exceed rated lift capacity.
- Excessive load can cause tipping or loss of control.
- Excessive load can cause failure of the lift eye and cause the load to drop.

W-2991-0714

Do not exceed the machine's Rated Lift Capacity or the Rated Lift Load (RLL) of the lifting device (lift eye). To determine the lift capacity changes, see the applicable lift capacity chart:

(See Rated Lift Capacity - Canopy With Heavy Counterweight on Page 172.), (See Rated Lift Capacity - Cab With Heavy Counterweight on Page 173.).

Make sure the secondary lifting system (chain) is of sufficient strength to lift the object.

Figure 136

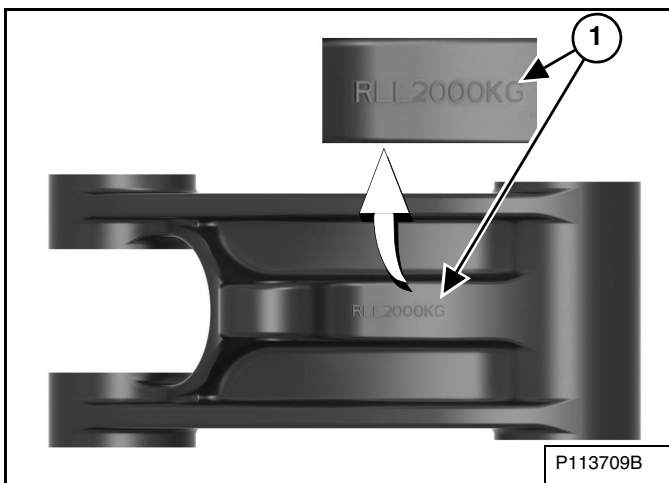

The maximum RLL (Item 1) [Figure 136] is shown on the lifting device.

Extend the bucket cylinder completely and lower the boom to the ground. Stop the engine. Exit the excavator. (See STOPPING THE ENGINE AND LEAVING THE EXCAVATOR on Page 76.)

Figure 137

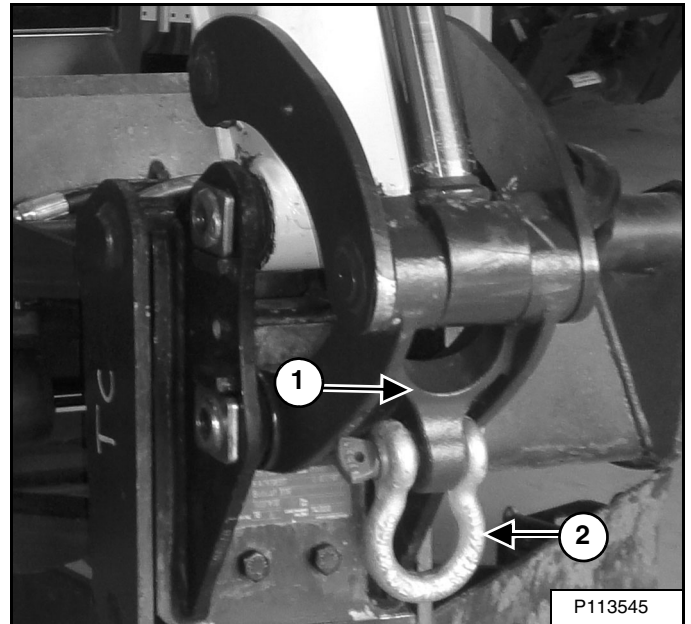

Install the clevis (Item 2) through the lift eye (Item 1) [Figure 137].

NOTE: Visually check the lifting eye, the clevis and the secondary lifting system (chain) for any damage. Replace any damage components before lifting. See your Bobcat dealer for replacement lift eye and clevis.

OPERATING PROCEDURE (CONT'D)

Object Handling With The Lifting Device (Cont'd)

Figure 138

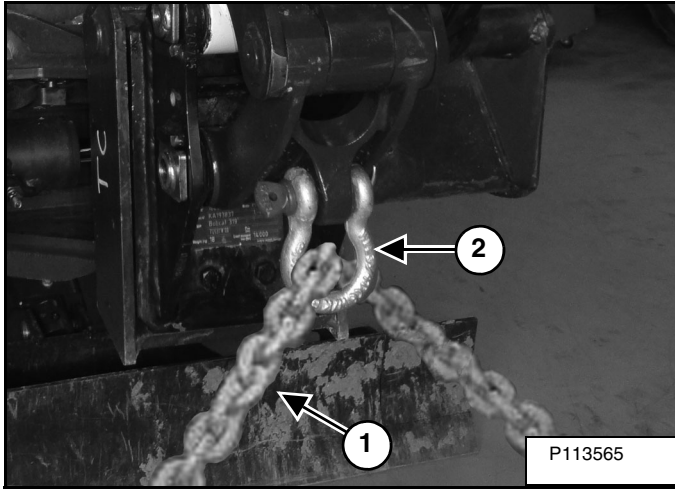

Install a lift chain (Item 1) (or other type of lifting device) through the clevis (Item 2) [Figure 138] and connect to the object to be lifted.

NOTE: Always use chains or other types of lifting devices that are intended for this type of use and that are of adequate strength for the object being lifted.

Enter the excavator, fasten the seat belt and start the engine. (See PRE-STARTING PROCEDURE on Page 69.)

Figure 139



Press the switch (Item 1) [Figure 139] to the left to activate the overload warning device (if equipped).

Figure 140

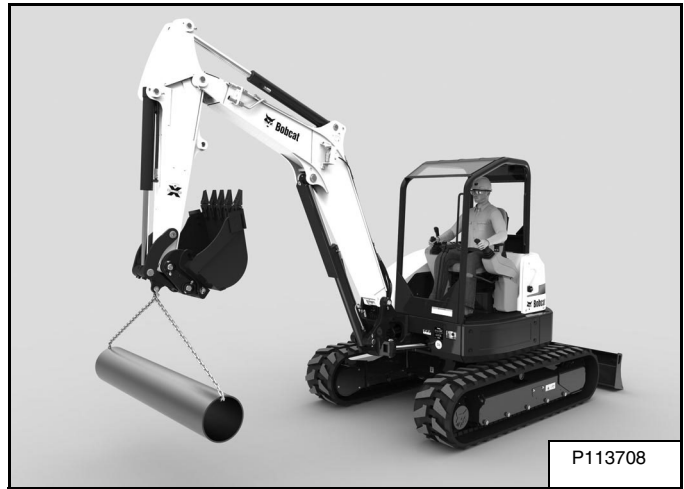

Make sure the load is evenly weighted and centered on the lifting chain (or other type of lifting device), and is secured to prevent the load from shifting [Figure 140].

Operate the controls slowly and smoothly to avoid suddenly swinging the lifted load.

Lift and position the load. When the load is placed in a secured position and tension is removed from the lift chain, remove the chain from the load and from the lift eye.

OPERATING PROCEDURE (CONT'D)

Lift Capacity

The lifting capacities were calculated with a Standard Configuration Machine (machine equipped with an X-Change quick-tach interface and no attachment). The weight of the attachment, the hydraulic clamp (if equipped), and different interface (if equipped), must be subtracted from the lift capacity to obtain the actual lift capacity.



WARNING

AVOID INJURY OR DEATH

Do not exceed rated lift capacity. Excessive load can cause tipping or loss of control.

W-2374-0500

Figure 141

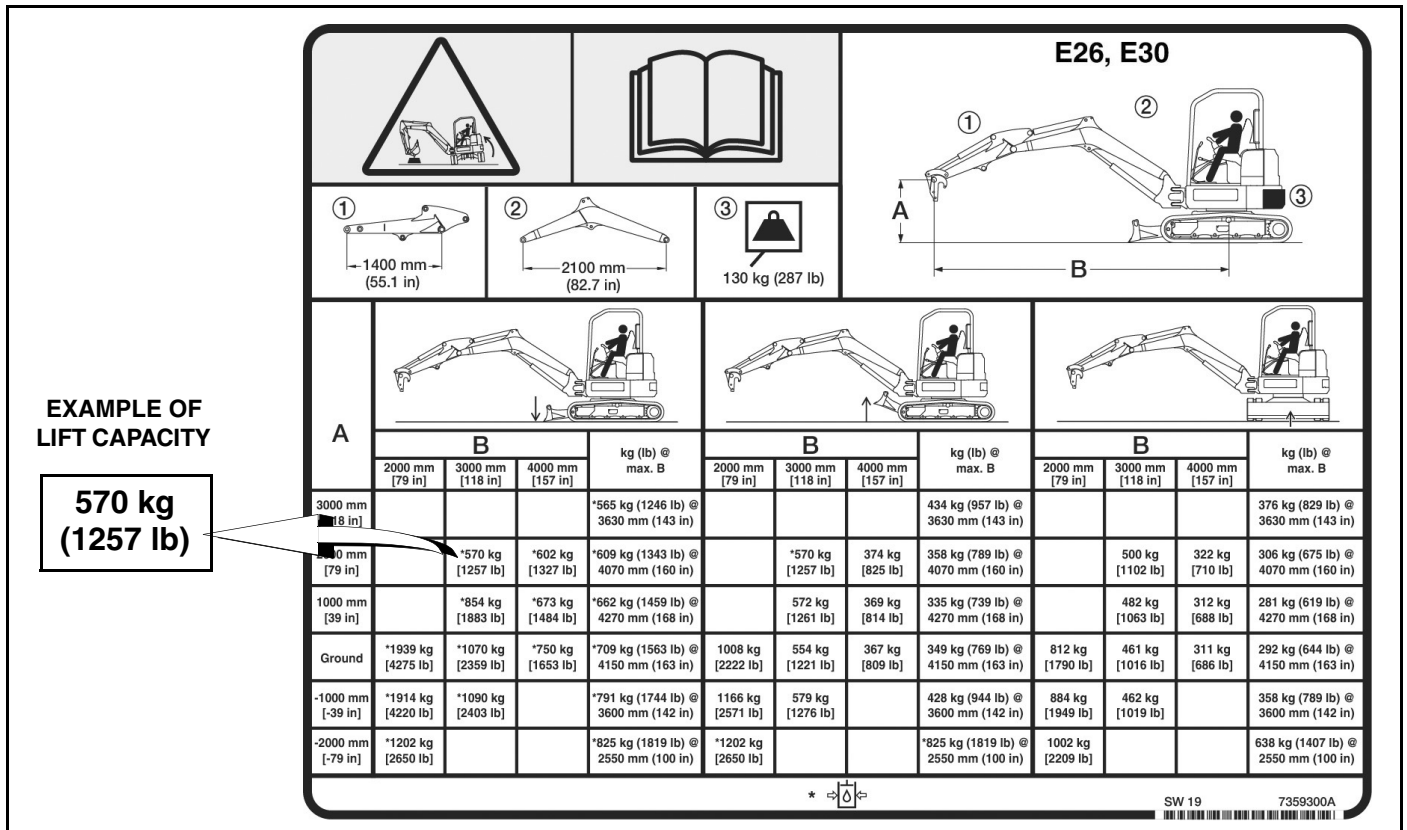

Detailed information about Quick Coupler and hydraulic clampweights can be found in documentation including its serial number plate. The following lists examples of the optional quick couplers and hydraulic clamp weights:

- Hydraulic Clamp And Cylinder = 54 kg (119 lb)
- Optional Buckets and Attachments (See **NOTE** below)

NOTE: For bucket weights, see your Bobcat dealer. For attachment weights, see the attachment Operation & Maintenance Manual.

The following example will show how to calculate the lift capacity differences between the lift capacity charts with standard equipment and when using optional equipment.

OPERATING PROCEDURE (CONT'D)

Lift Capacity (Cont'd)

The following is an example for determining the actual lift capacity using the sample chart shown above **[Figure 141]**.

- Machine Position: Over Blade, Blade Down
- Lift Radius: 3000 mm (118 in)
- Lift Point Height: 2000 mm (79 in)
- Hydraulic Clamp and Cylinder
- Standard Bucket

1. Obtain Lift Capacity from Chart: 570 kg (1257 lb)

2. Obtain the weights of optional equipment that reduces the lift capacity of the machine (coupling interface, hydraulic clamp, attachment).

Optional Equipment Weights: Standard Bucket 103 kg (226 lb) and Hydraulic Clamp and Cylinder 54 kg (119 lb)

3. Calculate the actual lift capacity by subtracting the weight of any optional equipment from the lift capacity of the standard configuration.

570 kg (1257 lb) - 103 kg (226 lb) (standard bucket) - 54 kg (119 lb) (hydraulic clamp and cylinder) = 413 kg (912 lb)

** The lift capacity charts (decals) are based off ISO 10567: 2007. The lifting capacities are defined as the lower value of 75% of the tipping load or 87% of the hydraulic lift capacity.*

OPERATING PROCEDURE (CONT'D)

Using The Clamp

Figure 142

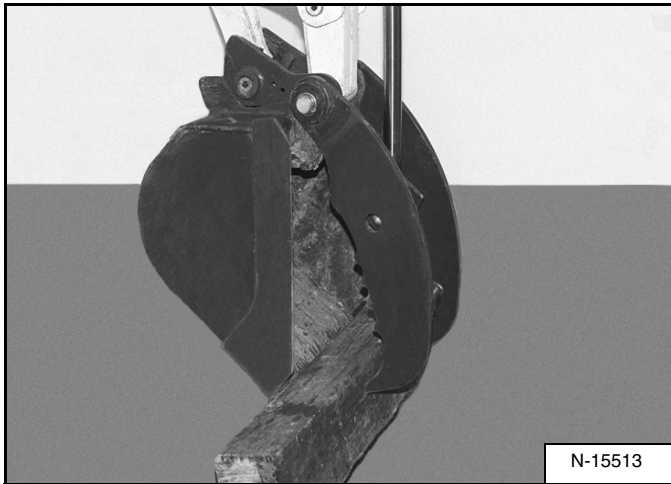

The optional lifting clamp attachment gives the excavator a wider range of use and mobility for debris removal [Figure 142].

The lifting clamp cylinder must be fully retracted when the machine is being used for excavating or other applications.

The lift capacities are reduced by 122 kg (270 lb) if the excavator is equipped with the optional lifting clamp.

NOTE: Use care when operating the bucket and clamp functions on machines equipped with an attachment mounting system and without a bucket or attachment installed. Cylinder damage can occur due to contact between the attachment mounting system and the clamp when both cylinders are fully extended.

Using Primary Auxiliary Hydraulics To Activate Clamp

1. Engage the auxiliary hydraulics. (See Activating Primary Auxiliary Hydraulics With Standard Instrument Panel on Page 53.) (See Activating Primary Auxiliary Hydraulics With Deluxe Instrument Panel (Software Version 88.09 Or Below) on Page 54.) (See Activating Primary Auxiliary Hydraulics With Deluxe Instrument Panel (Software Version 88.10 Or Above) on Page 54.).
2. Set auxiliary flow rate to Mode 2 (standard instrument panel) or 65 – 75% (deluxe instrument panel).

Figure 143

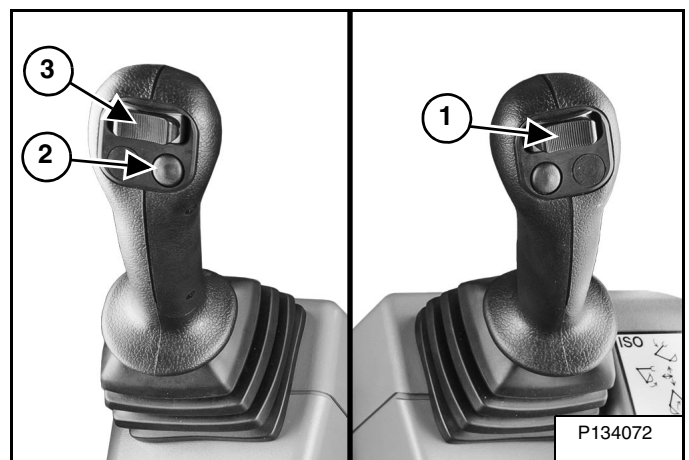

3. Move the switch (Item 1) [Figure 143] on the right joystick to the right to open the clamp. Move the switch to the left to close the clamp.

Using Secondary Auxiliary Hydraulics To Activate Clamp

1. Engage the auxiliary hydraulics (See Operating Attachments With Secondary Auxiliary Hydraulics (Software Version 88.09 Or Below) on Page 58.) (See Operating Attachments With Secondary Auxiliary Hydraulics (Software Version 88.10 Or Above) on Page 59.).
2. Press the button on the left joystick (Item 2) to toggle to the second auxiliary hydraulics.

Move the switch (Item 3) [Figure 143] on the left joystick to the left open the clamp. Move the switch to the right to close the clamp.

OPERATING PROCEDURE (CONT'D)

Driving The Excavator

When operating on uneven ground, operate as slow as possible and avoid sudden changes in direction.

Avoid traveling over objects such as rocks, trees, stumps, etc.

When working on wet or soft ground, put planks on the ground to provide a solid base to travel on and prevent the excavator from getting stuck.

Figure 144

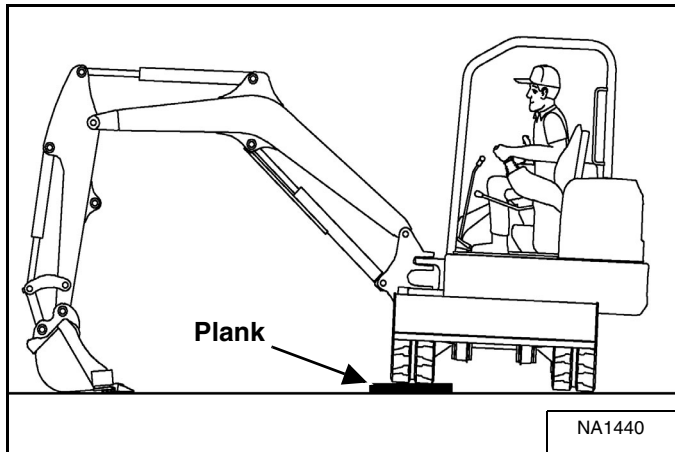

If one or both tracks have become stuck in soft or wet ground, raise one track at a time by turning the upperstructure and pushing the bucket against the ground [Figure 144].

Put planks under the tracks and drive the excavator to dry ground.

Figure 145

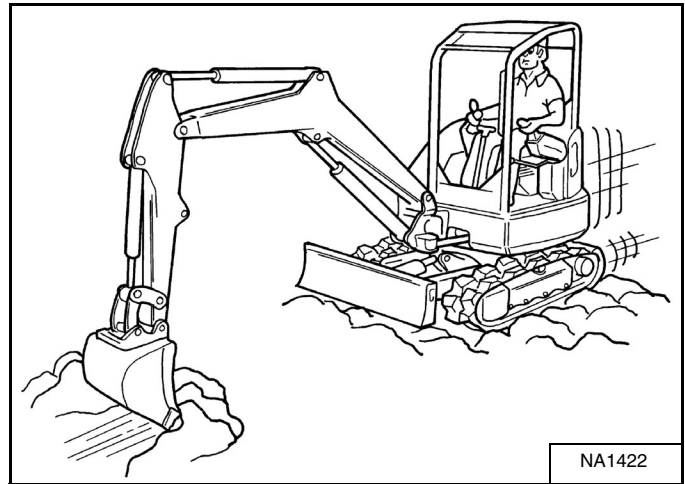

The bucket may also be used to pull the excavator. Raise the blade, extend the arm and lower the boom. Operate the boom and arm in a digging manner [Figure 145].

OPERATING PROCEDURE (CONT'D)

Operating On Slopes

! WARNING

INSTABILITY HAZARD

Machine tipping or rollover can cause serious injury or death.

- Do not travel across or up slopes that are over 15 degrees.
- Do not travel down or back up slopes that exceed 25 degrees.
- Look in the direction of travel.
- Check for adequate traction.

W-2497-1024

When going down a slope, control the speed with the steering levers and the speed control lever.

Figure 146

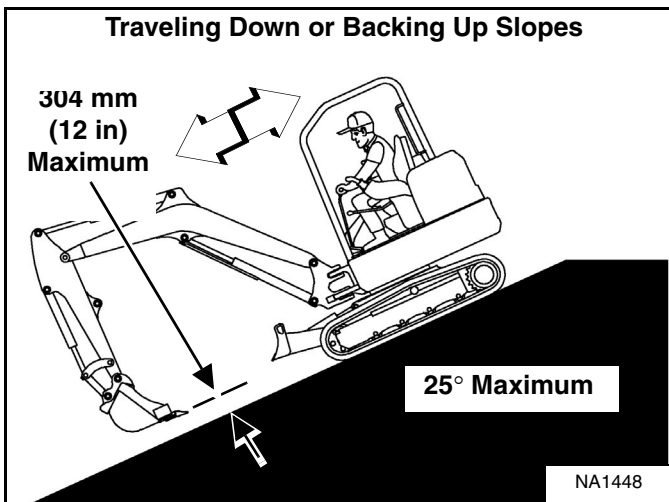

When going down grades that exceed 15 degrees, put the machine in the position shown, and run the engine slowly [Figure 146].

Operate as slow as possible and avoid sudden changes in lever direction.

Avoid traveling over objects such as rocks, trees, stumps, etc.

Stop the machine before moving the upper equipment controls. Never allow the blade to strike a solid object. Damage to the blade or hydraulic cylinder can result.

! WARNING

INSTABILITY HAZARD

Machine tipping or rollover can cause serious injury or death.

- Always fasten seat belt.
- Avoid steep areas or banks that could break away.
- Keep boom centered and attachments as low as possible when traveling on slopes or in rough conditions.
- Look in the direction of travel.
- Keep feet and hands on controls.

W-2498-1024

Figure 147

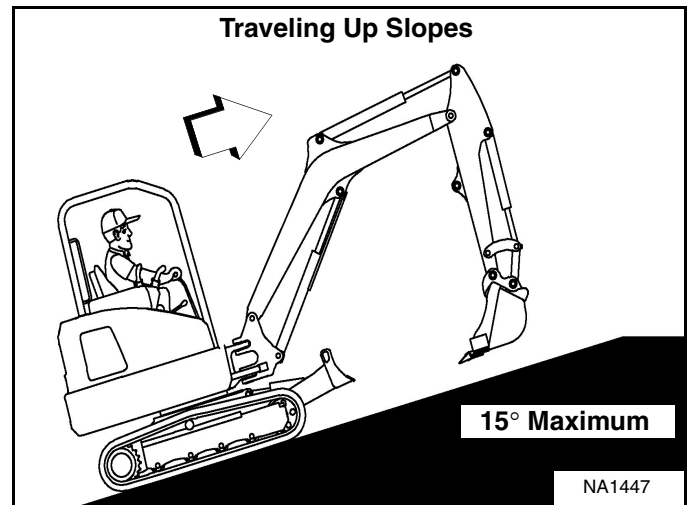
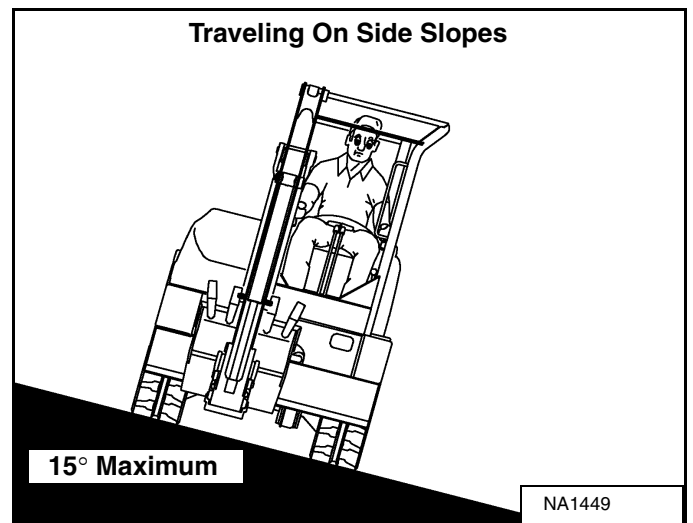

Figure 148



When traveling up slopes or on side slopes that are 15 degrees or less, position the machine as shown and run the engine slow [Figure 147] and [Figure 148].

OPERATING PROCEDURE (CONT'D)

Operating On Slopes (Cont'd)

Figure 149

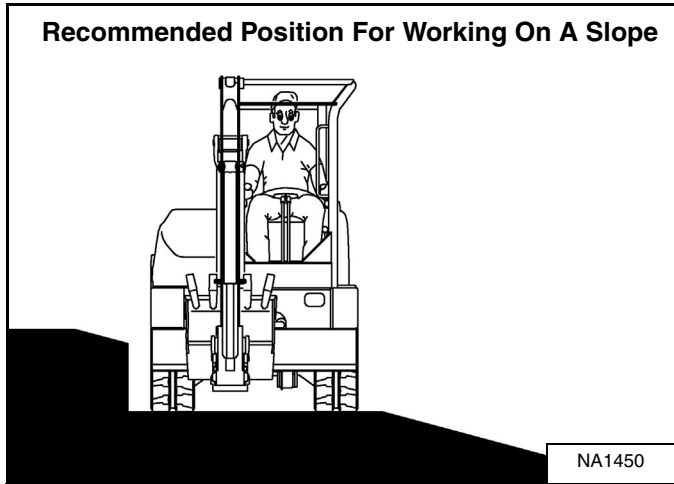

When operating on a slope, level the work area before beginning [Figure 149].

If this is not possible, the following procedures should be used:

Do not work on slopes which are over 15 degrees.

Use a slow work cycle.

Avoid working with the tracks across the slope. This will reduce stability and increase the tendency for the machine to slide. Position the excavator with the blade downhill and lowered.

Avoid swinging or extending the bucket more than necessary in a down hill direction. When you must swing the bucket downhill, keep the arm low and skid the bucket downhill.

When working with the bucket on the uphill side, keep the bucket as close to the ground as possible. Dump the spoil far enough away from the trench or hole to prevent the possibility of a cave in.

Figure 150

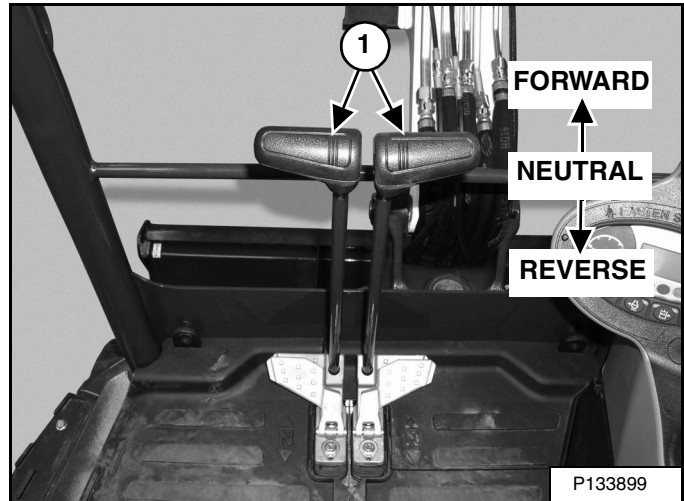

To brake the machine when going down a slope, move the steering levers (Item 1) [Figure 150] to the NEUTRAL position. This will engage the hydrostatic braking.

When the engine stops on a slope, move the steering levers to the NEUTRAL position. Lower the boom / bucket to the ground.

NOTE: If the engine stops, the boom / bucket (attachments) can be lowered to the ground using hydraulic pressure which is stored in the accumulator.

The console must be in the locked down position, and the key switch in the ON position.

Use the control lever to lower the boom.

Start the engine and resume operation.

OPERATING PROCEDURE (CONT'D)

Operating In Water

Mud and water should be removed from the machine before parking. In freezing temperatures, park the machine on boards or concrete to prevent the track or undercarriage from freezing to the ground and preventing machine movement.

Figure 151

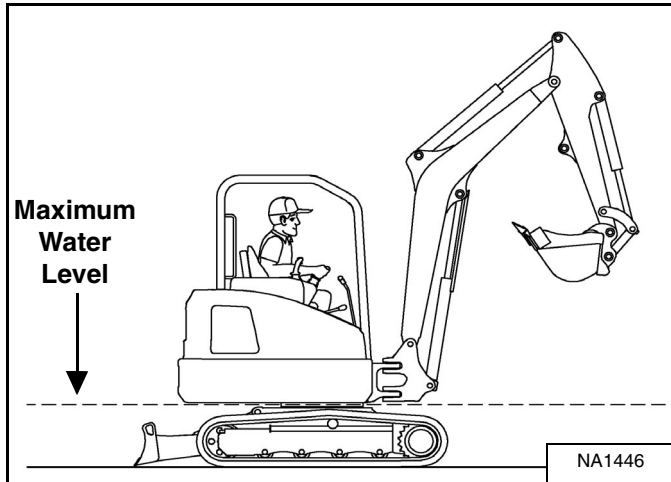

Do not operate or immerse the excavator in water higher than the bottom of the swing bearing **[Figure 151]**.

Grease the excavator when it has been operated or immersed in water for a period of time. Greasing forces the water out of the lubrication areas.

Water must be removed from the cylinder rods. If water freezes to the cylinder rod, the cylinder seals can be damaged when the rod is retracted.

OPERATING PROCEDURE (CONT'D)

Avoiding Track Damage

Mud and water should be removed from the machine before parking. In freezing temperatures, park the machine on boards or concrete to prevent the track or undercarriage from freezing to the ground and preventing machine movement.

Some Cause Of Track Damage:

Figure 152

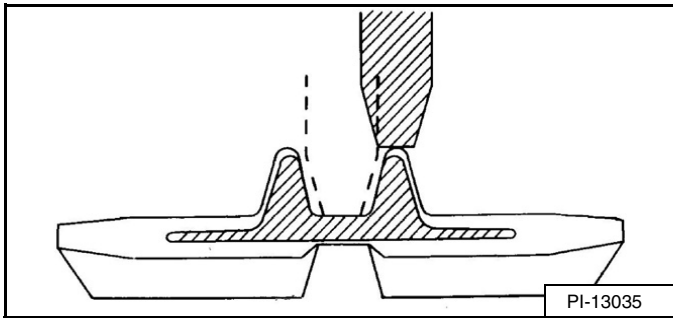

Incorrect track tension: When the rubber track is detracting, the idler or sprocket rides on the projections of the embedded metal **[Figure 152]** causing the embedded metal to be exposed to corrosion. (See TRACK TENSION on Page 142.)

If rubber track is clogged with stones or foreign objects, these can get wedged between the sprocket / rollers and cause detracting and track stress.

When moisture invades through cuts on the track, the embedded steel cords will corrode. The deterioration of the design strength may lead to the breaking of the steel cords.

Figure 153

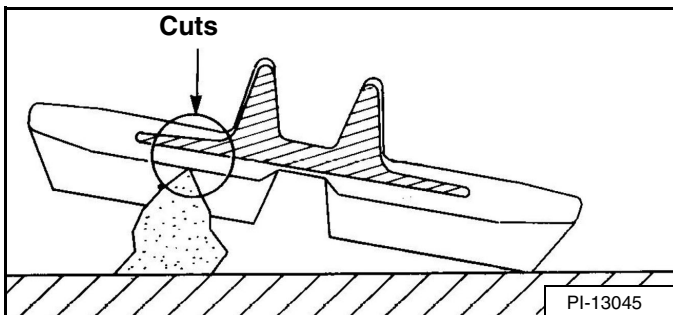

When rubber tracks drive over projections or sharp objects in the field, the concentrated forces applied cause cuts on the lug side rubber surface **[Figure 153]**. In case of making turns on projections, the lug side rubber surface will have an even higher chance to be cut. If the cuts run through the embedded steel cords, it might result in the steel cords' breakage due to their corrosion.

Avoid quick turns on bumpy and rocky fields.

Driving over sharp objects should be avoided. If this is impossible, do not make turns while driving over sharp objects.

Figure 154

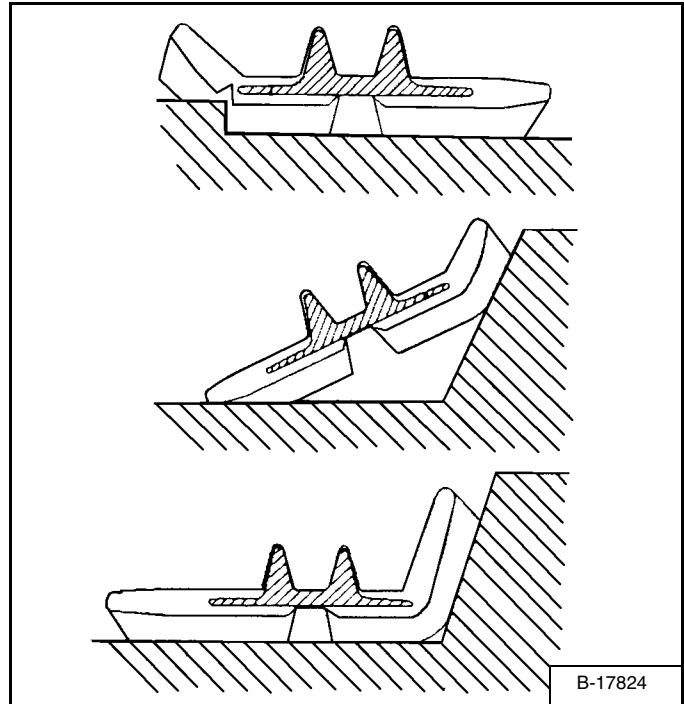

When rubber tracks drive over sharp projections, intensive stress is applied to the lug side rubber surface, especially at the edges of embedded metals, causing cracks and cuts in the area around the embedded metals **[Figure 154]**.

Avoid extensive stress applied to the lug root where metals are embedded. Operators should try to avoid driving over stumps and ridges.

TOWING THE EXCAVATOR

Procedure

There is not a recommended towing procedure for the excavators.

The excavator can be lifted onto the transport vehicle. (See LIFTING THE EXCAVATOR on Page 100.)

Figure 155

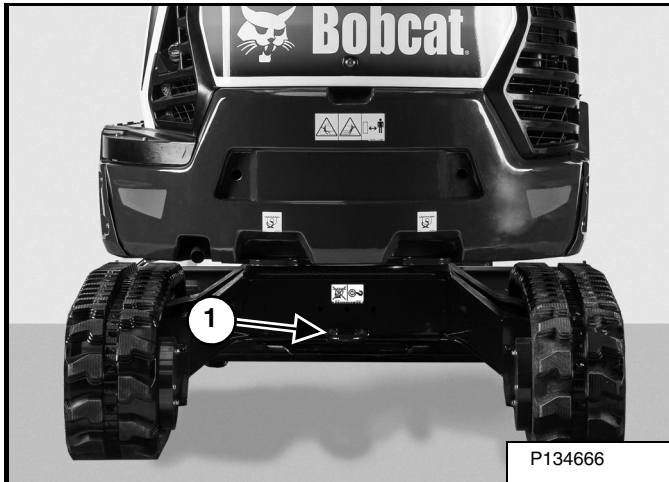

The excavator can be skidded a short distance for service (for example, moving it onto a transport vehicle) without damaging the hydraulic system. (The tracks will not turn.) There might be slight wear to the tracks when the excavator is skidded.

Secure the towing chain to the loop located at the rear of the excavator (Item 1) **[Figure 155]**.

The towing chain (or cable) must be rated at 1.5 times the weight of the excavator. (See Performance on Page 174.)

LIFTING THE EXCAVATOR

Procedure

Figure 156



Before lifting, fully extend the cylinders of the bucket, arm, and boom. Raise the blade fully. Turn the upperstructure so the boom and blade are at opposite ends of the excavator as shown [Figure 156].

Put all the control levers in NEUTRAL and stop the machine.



AVOID INJURY OR DEATH

- Use chains and lifting equipment with sufficient capacity for the weight of the excavator plus any added attachments.
- Maintain center of gravity and balance when lifting.
- Do not swing boom or upperstructure.
- Never lift with operator on machine.
- Never lift with the blade angled (if equipped).

W-2800-0709

Figure 157



Fasten chains to the ends of the blade (Item 1) [Figure 157] and up to a lifting fixture above the canopy / cab. The lifting fixture must extend over the sides of the canopy / cab to prevent the chains from hitting the ROPS / TOPS.

Figure 158



Fasten a chain from the boom to the lift fixture (Item 1) [Figure 158].

Figure 159

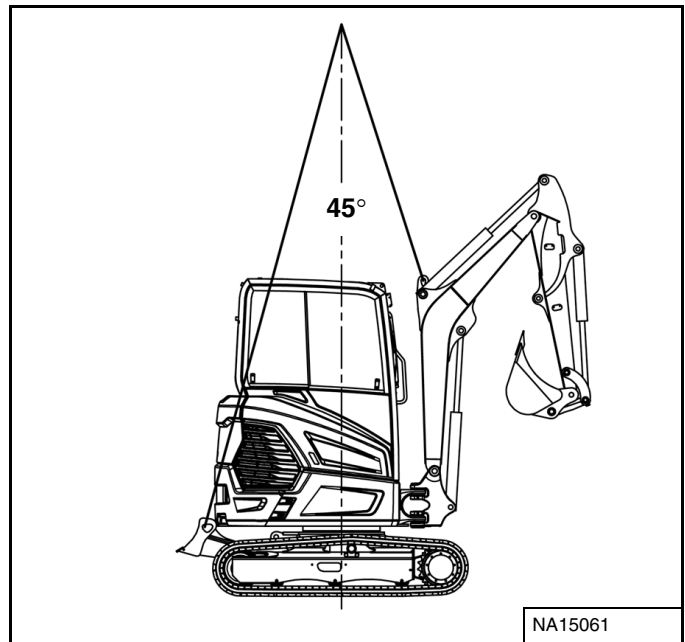

The excavator should remain as close to horizontal as possible while it is lifted. To prevent damage, the chains should not contact any part of the operator canopy / cab. The chains should be at an angle of 45 degrees [Figure 159].

TRANSPORTING THE EXCAVATOR ON A TRAILER

Loading And Unloading

When transporting the machine, observe the rules, motor vehicle laws, and vehicle limit ordinances. Use a transport and towing vehicle of adequate length and capacity.

Secure the parking brakes and block the wheels of the transport vehicle.

Align the ramps with the center of the transport vehicle. Secure the ramps to the truck bed and be sure ramp angle does not exceed 15 degrees.

Use metal loading ramps with a slip resistant surface.

Use ramps that are the correct length and width and can support the weight of the machine.

The rear of the trailer must be blocked or supported when loading or unloading the machine to prevent the front of the transport vehicle from raising.

Determine the direction of the track movement before moving the machine (blade forward).

Disengage the auto idle feature and move the two speed travel to the low range position.



WARNING

INSTABILITY HAZARD

Wood ramps can break and cause personal injury. Use adequately designed ramps of sufficient strength to support the weight of the machine loading onto a transport vehicle.

W-2058-0824

Figure 160



Move the machine forward onto the transport vehicle **[Figure 160]**.

Do not change direction of the machine while it is on the ramps.

Lower the boom, arm, bucket, and blade to the transport vehicle.

Stop the engine and remove the key (if equipped).

Put blocks at the front and rear of the tracks.

TRANSPORTING THE EXCAVATOR ON A TRAILER (CONT'D)

Fastening

Tie down the excavator to prevent it from moving when going up or down slopes or during sudden stops.

Tie-Down Points At The Front Of The Excavator:

Figure 161

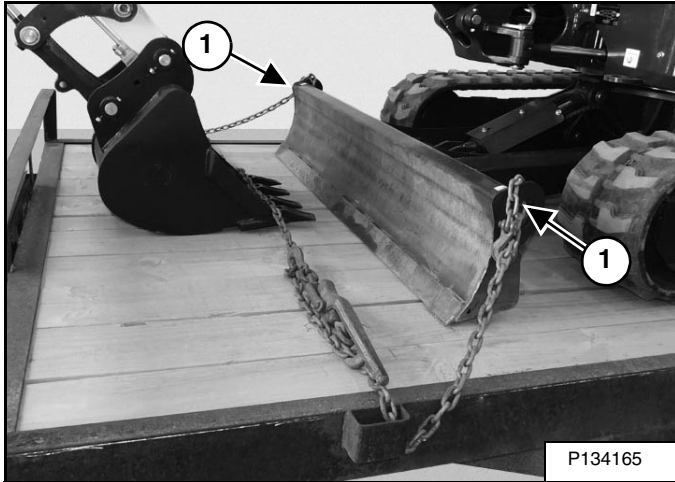

Tie-Down Points At The Rear Of The Excavator:

Figure 163

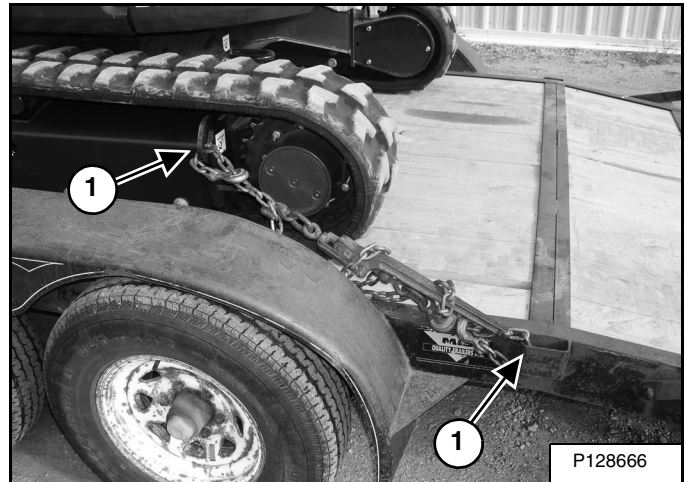

Figure 162

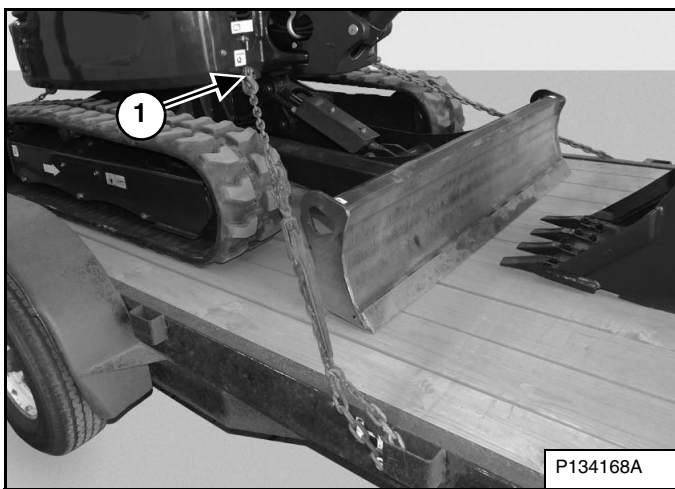
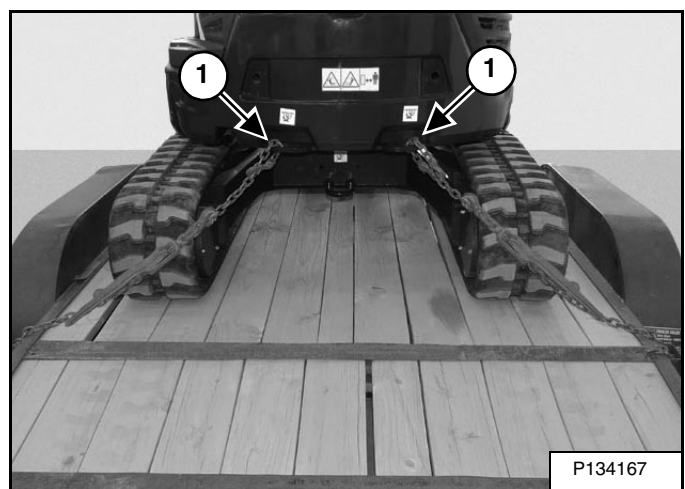

Figure 164



Fasten chains to the front corners of the blade (Item 1) [Figure 161] or to the tie-down loops at the front of the upperstructure (Item 1) [Figure 162].

Fasten chains to the tie-down loops at the rear corners of the track frame (Item 1) [Figure 163] or to the tie-down holes at the rear of the upperstructure (Item 1) [Figure 164].

TRANSPORTING THE EXCAVATOR ON A TRAILER (CONT'D)

Fastening (Cont'd)

Figure 165

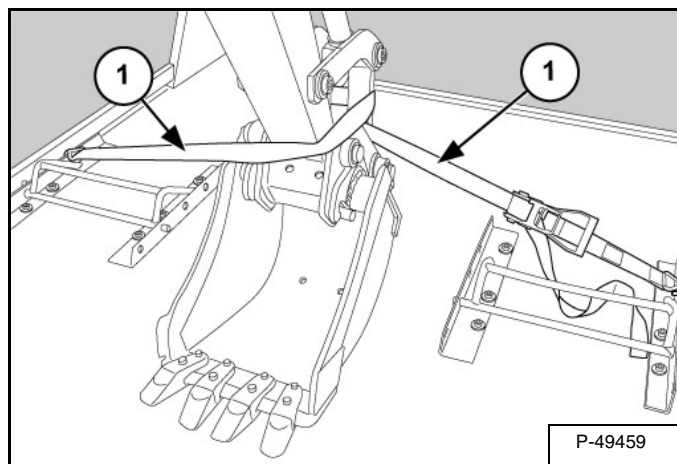

Loop a chain (Item 1) **[Figure 165]** around the bucket link and to the trailer.

Use chain binders to tighten the chains and then safely tie the chain binder levers to prevent loosening.

PREVENTIVE MAINTENANCE

MAINTENANCE SAFETY	107
SERVICE SCHEDULE	108
Maintenance Intervals	108
CONTROL CONSOLE LOCKOUTS	110
Inspection And Maintenance	110
SEAT BELT	111
Inspection And Maintenance	111
MOTION ALARM SYSTEM	112
Description	112
Inspecting	112
Adjusting Switch Position	113
TAILGATE	114
Opening And Closing	114
Adjusting The Latch	114
RIGHT SIDE COVER	115
Opening And Closing	115
RIGHT SIDE PANEL	116
Removing And Reinstalling	116
CAB FILTERS	117
Cleaning And Maintenance	117
HEATING AND VENTILATION	118
Cleaning And Maintenance	118
AIR CLEANER SERVICE	119
Replacing The Filter Elements	119
FUEL SYSTEM	121
Fuel Specifications	121
Biodiesel Blend Fuel	121
Filling The Fuel Tank	122
Fuel Filters	123
Draining The Fuel Tank	123
Removing Air From The Fuel System	124
ENGINE LUBRICATION SYSTEM	125
Checking And Adding Engine Oil	125
Engine Oil Chart	125
Removing And Replacing Oil And Filter	126

ENGINE COOLING SYSTEM	127
Cleaning	127
Coolant Types	127
Coolant Concentration	128
Checking Level	128
Removing And Replacing Coolant	129
ELECTRICAL SYSTEM	131
Description	131
Fuse And Relay Location / Identification	131
Battery Maintenance	134
Maintaining Battery Charge Level	134
Battery Service During Machine Storage	134
Battery Testing	135
Battery Charging	135
Using A Booster Battery (Jump Starting)	136
Removing And Installing The Battery	137
HYDRAULIC SYSTEM	138
Checking And Adding Hydraulic Oil	138
Hydraulic / Hydrostatic Fluid Chart	139
Removing And Replacing The Hydraulic Filters	139
Removing And Replacing The Hydraulic Fluid	140
SPARK ARRESTER MUFFLER	141
Cleaning Procedure	141
TRACK TENSION	142
Adjusting	142
TRAVEL MOTOR	144
Checking And Adding Oil	144
Removing And Replacing Oil	144
ALTERNATOR AND FAN BELT	145
Belt Adjustment	145
Belt Replacement	145
X-CHANGE	147
Inspection And Maintenance	147
BUCKET	147
Bucket Teeth Removal And Installation	147
TRACK ROLLER AND IDLER LUBRICATION	148
Procedure	148
Lubrication Locations	148
PIVOT PINS	150
Inspection And Maintenance	150

EXCAVATOR STORAGE AND RETURN TO SERVICE151
Storage151
Return To Service151

MAINTENANCE SAFETY



WARNING

Instructions are necessary before operating or servicing machine. Read and understand the Operation & Maintenance Manual, Operator's Handbook and signs (decals) on machine. Follow warnings and instructions in the manuals when making repairs, adjustments or servicing. Check for correct function after adjustments, repairs or service. Untrained operators and failure to follow instructions can cause injury or death.

W-2003-0807



Safety Alert Symbol: This symbol with a warning statement, means: "Warning, be alert! Your safety is involved!" Carefully read the message that follows.

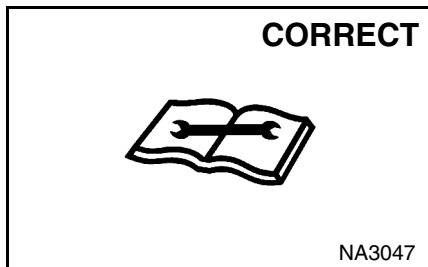

NA3047

- ⚠ Never service the Bobcat Compact Excavator without instructions.

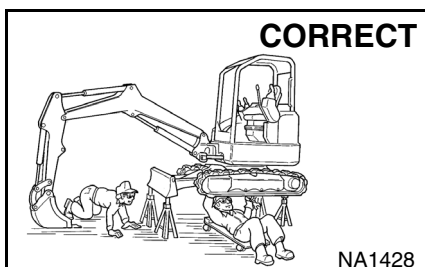

NA1428

- ⚠ Use the correct procedure to lift and support the excavator.

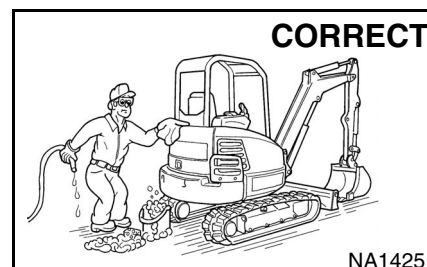

NA1425

- ⚠ Cleaning and maintenance are required daily.

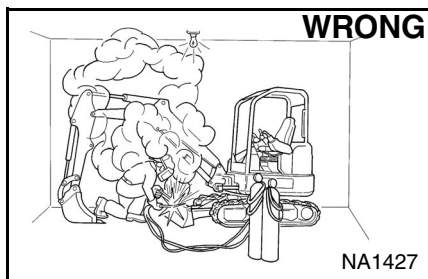

NA1427

- ⚠ Have good ventilation when welding or grinding painted parts.
- ⚠ Wear dust mask when grinding painted parts. Toxic dust and gas can be produced.

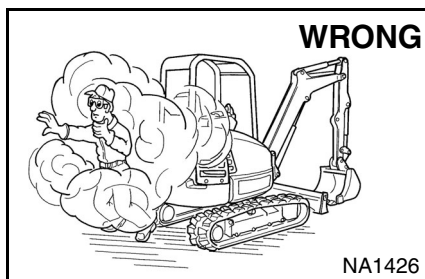

NA1426

- ⚠ Vent exhaust to outside when engine must be run for service.
- ⚠ Exhaust system must be tightly sealed. Exhaust fumes can kill without warning.

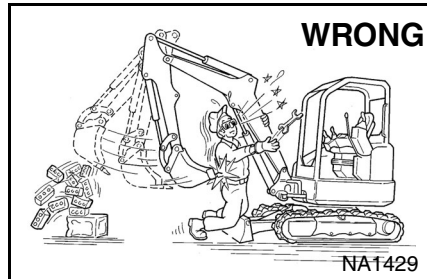

NA1429

- ⚠ Always lower the bucket and blade to the ground before doing any maintenance.
- ⚠ Never modify equipment or add attachments not approved by Bobcat Company.

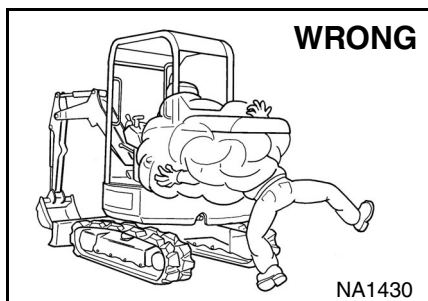

NA1430

- ⚠ Stop, cool and clean engine of flammable materials before checking fluids.
- ⚠ Never service or adjust machine with the engine running unless instructed to do so in the manual.
- ⚠ Avoid contact with leaking hydraulic fluid or diesel fuel under pressure. It can penetrate the skin or eyes.
- ⚠ Never fill fuel tank with engine running, while smoking, or when near open flame.

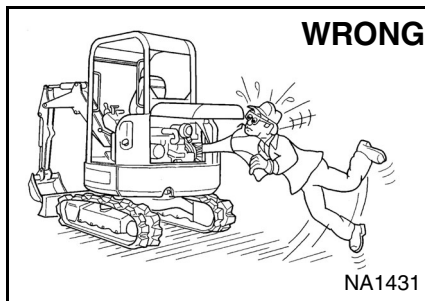

NA1431

- ⚠ Keep body, jewelry and clothing away from moving parts, electrical contact, hot parts and exhaust.
- ⚠ Wear eye protection to guard from battery acid, compressed springs, fluids under pressure and flying debris when engines are running or tools are used. Use eye protections approved for type of welding.
- ⚠ Keep tailgate closed except for service. Close and latch tailgate before operating the excavator.

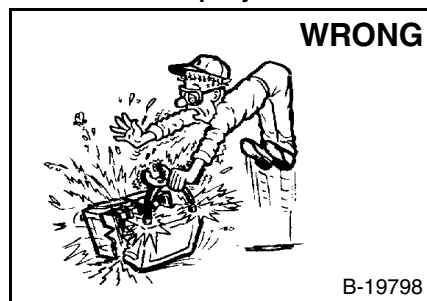

B-19798

- ⚠ Lead-acid batteries produce flammable and explosive gases.
- ⚠ Keep arcs, sparks, flames and lighted tobacco away from batteries.
- ⚠ Batteries contain acid which burns eyes or skin on contact.
- ⚠ Wear protective clothing. If acid contacts body, flush well with water. For eye contact flush well and get immediate medical attention.

Maintenance procedures which are given in the Operation & Maintenance Manual can be performed by the owner/operator without any specific technical training. Maintenance procedures which are **not** in the Operation & Maintenance Manual must be performed **ONLY BY QUALIFIED BOBCAT SERVICE PERSONNEL**. Always use genuine Bobcat replacement parts. The Service Safety Training Course is available from your Bobcat dealer.

MSW38-0421

SERVICE SCHEDULE

Maintenance Intervals

Maintenance work must be done at regular intervals. Failure to do so will result in excessive wear and early failures.

The service schedule is a guide for correct maintenance of the Bobcat excavator.



The service schedule decal is located under the right cover on the hydraulic tank. See inside page of the back cover for symbols and identification.

Every 10 Hours (Before Starting The Excavator)

- **Engine Oil** - Check level and add as needed. (See Page 126.)
- **Engine Air Filters and Air System** - Check condition indicator. Service only when required. Check for leaks and damaged components. (See Page 119.)
- **Engine Cooling System** - Check coolant level COLD and add premixed coolant as needed. (See Page 128.), (See Coolant Types on Page 127.) and (See Coolant Concentration on Page 128.)
- **Seat Belt, Seat Belt Retractors, Seat Belt Mounting hardware** - Check the condition of seat belt and mounting hardware. Clean or replace seat belt retractors as needed. Clean dirt and debris from moving parts. (See Page 111.)
- **Motion Alarm** - Check for proper function (if equipped). (See Page 112.)
- **Control Console Lockout** - Check the control console lockout lever for proper operation. (See Page 110.)
- **Operator Canopy / Cab** - Check the canopy / cab condition and mounting hardware. (See Page 41.)
- **Operator Cab and HVAC Filters** - Clean filters. (See Page 117.)
- **Indicators and Lights** - Check for correct operation of all indicators and lights. (See Page 31.)
- **Safety Signs** - Check for damaged signs (decals). Replace any signs that are damaged. (See Page 14.)
- **Hydraulic Fluid** - Check fluid level and add as needed. (See Page 138.)
- **Track Tension** - Check tension and adjust as needed. (See Page 142.)
- **Pivot Points** - Grease all machinery pivot points. Grease clamp (if equipped). (See Page 150.)
- **X-Change** - Check for damage or loose parts (if equipped). (See Page 147.)
- **Fuel Filter** - Drain water and sediment. (See Page 123.)

First 50 Hours

- **Fuel Filter** - Change filter. (See Page 123.)
- **Engine Oil and Filter** - Replace oil and filter. (See Page 126.)
- **Drive Belts (Alternator)** - Check condition. Replace as needed. (See Page 145.)
- **Hydraulic Filter and Case Drain Filter** - Replace the hydraulic filter and the case drain filter. (See Page 139.)
- **Alternator and Starter** - Check connections.



WARNING

INSUFFICIENT INSTRUCTIONS HAZARD

Untrained operators or failure to obey instructions can cause serious injury or death.

- **Obey warnings and instructions in the Operation & Maintenance Manual, Operator's Handbook, and decals on machine.**
- **Obey warnings and instructions in the manuals when making repairs, adjustments, or servicing.**
- **Check for correct function after adjustments, repairs, or service.**

W-2003-0425

SS EXC E26-27 T4 S5 K - 0319

SERVICE SCHEDULE (CONT'D)

Maintenance Intervals (Cont'd)

Every 50 Hours

- **Swing Bearing** - Grease swing bearing and swing pinion. Service every 10 hours when operating in water. (See Page 148.)

Every 100 Hours

- **Spark Arrester** - Empty spark chamber. (See Page 141.)

First 250 Hours

- **Travel Motors (Final Drive)** - Replace fluid. (See Page 144.)

Every 250 Hours Or Every 12 Months

- **Battery** - Check cables and connections. (See Page 137.)
- **Fuel Filter** - Change fuel filter and pre-filter. (See Page 123.)
- **Travel Motors (Final Drive)** - Check fluid level and add as needed. (See Page 144.)
- **Engine Oil and Filter** - Replace oil and filter. (See Page 126.)

Every 500 Hours Or Every 12 Months

- **Engine Air Filters and Air System** - Check condition indicator. Service only when required. Check for leaks and damaged components. (See Page 119.)
- **Engine Cooling System** - Clean debris from radiator, fuel cooler and hydraulic fluid cooler. (See Page 127.)
- **Drive Belts (Alternator)** - Check condition. Replace as needed. (See Page 145.)
- **Hydraulic Filter, Case Drain Filter, and Hydraulic Reservoir Breather Cap** - Replace the hydraulic filter, case drain filter, and reservoir breather cap. (See Page 139.)
- **Alternator and Starter** - Check connections.

Every 1000 Hours Or Every 12 Months

- **Engine Valves** - Adjust the engine valve clearance.
- **Travel Motors (Final Drive)** - Replace fluid. (See Page 144.)
- **Hydraulic Fluid and Filters** - Replace hydraulic fluid and filters. (See Page 139.)

Every 24 Months

- **Coolant** - Replace the coolant. (See Page 129.)

SS EXC E26-27 T4 S5 K - 0319

CONTROL CONSOLE LOCKOUTS

Inspection And Maintenance

Figure 166

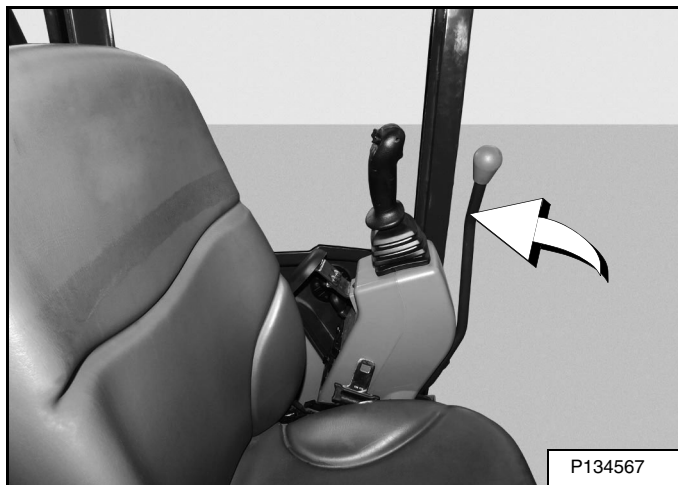

When the left console is raised **[Figure 166]**, the hydraulic joysticks and traction system must not function.

Sit in the operator's seat, fasten the seat belt and start the engine.

Raise the left console **[Figure 166]**.

Move the joysticks. There should be no movement of the boom, arm, slew or bucket.

Move the steering control levers. There should be no movement of the excavator tracks.

Service the system if these controls do not deactivate when the left control console is raised. (See your Bobcat dealer for service.)

SEAT BELT

Inspection And Maintenance

WARNING

Failure to properly inspect and maintain the seat belt can cause lack of operator restraint resulting in serious injury or death.

W-2466-0703

Check the seat belt daily for correct function.

Inspect the seat belt system thoroughly at least once each year or more often if the machine is exposed to severe environmental conditions or applications.

Any seat belt system that shows cuts, fraying, extreme or unusual wear, significant discolorations due to ultraviolet UV exposure, dusty / dirty conditions, abrasion to the seat belt webbing, or damage to the buckle, latch plate, retractor (if equipped), hardware or any other obvious problem should be replaced immediately.

The items below are referenced in **[Figure 167]**.

1. Check the webbing. If the system is equipped with a retractor, pull the webbing completely out and inspect the full length of the webbing. Look for cuts, wear, fraying, dirt, and stiffness.
2. Check the buckle and latch for correct operation. Make sure latch plate is not excessively worn, deformed or buckle is not damaged or casing broken.
3. Check the retractor web storage device (if equipped) by extending webbing to determine if it looks correct and that it spools out and retracts webbing correctly.
4. Check webbing in areas exposed to ultraviolet (UV) rays from the sun or extreme dust or dirt. If the original color of the webbing in these areas is extremely faded and / or the webbing is packed with dirt, the webbing strength may have deteriorated.

See your Bobcat dealer for seat belt system replacement parts for your machine.

Figure 167

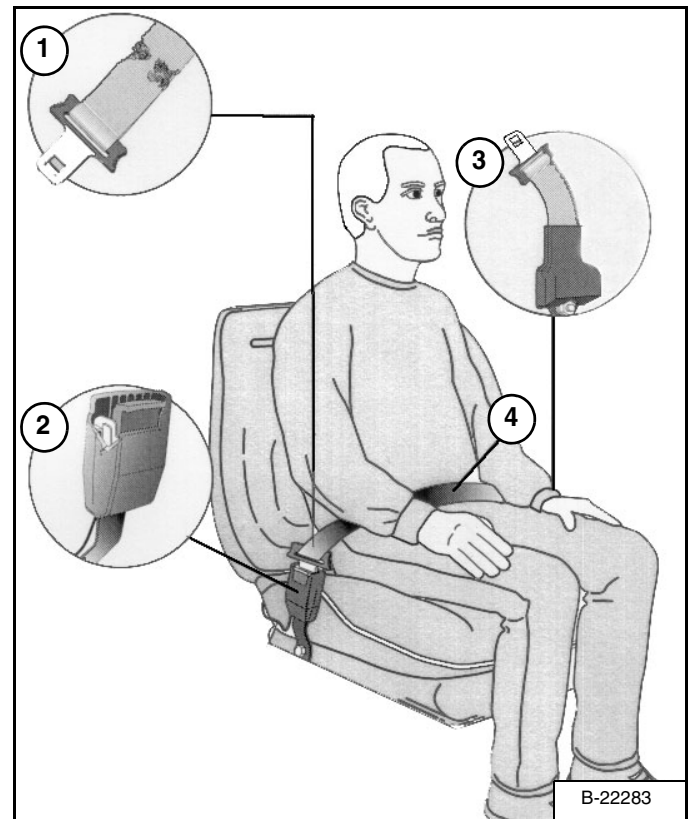

MOTION ALARM SYSTEM

Description

This excavator may be equipped with a motion alarm system. The motion alarm will sound when the operator moves the travel control levers in either the forward or reverse direction. Slight movement of the steering levers in either the forward or reverse direction is required with hydraulic components before the motion alarm will sound.

Inspecting

Figure 168

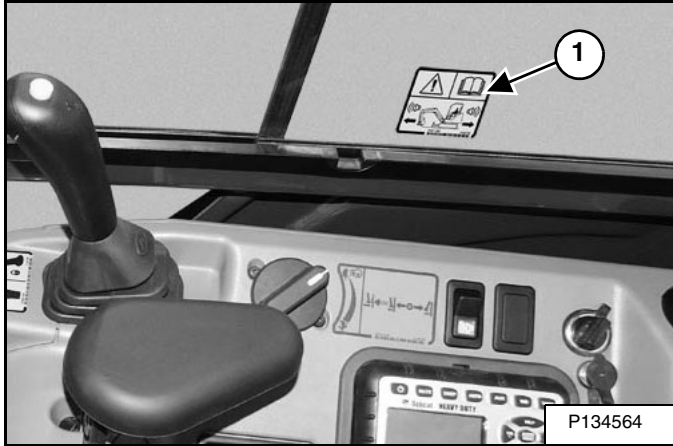
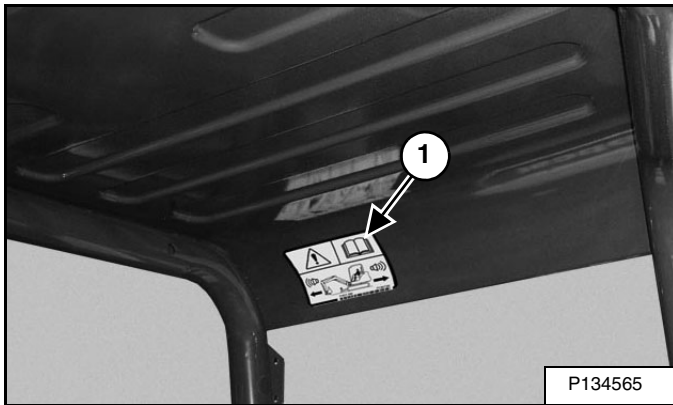

Figure 169



Inspect for damaged or missing motion alarm decal (Item 1) [Figure 168] (cab machine) or (Item 1) [Figure 169] (canopy machine). Replace if required.

NOTE: The excavator will need to be moved slightly in both the forward and reverse direction to test the motion alarm. Keep all bystanders away from machine during test.

WARNING

AVOID INJURY OR DEATH

When an engine is running in an enclosed area, fresh air must be added to avoid concentration of exhaust fumes. If the engine is stationary, vent the exhaust outside. Exhaust fumes contain odorless, invisible gases which can kill without warning.

W-2050-0807

Sit in the operator's seat and fasten the seat belt. Start the engine. (See PRE-STARTING PROCEDURE on Page 69.)

Move the travel control levers (one lever at a time) in the forward direction. The motion alarm must sound. Move the travel control levers (one lever at a time) in the reverse direction. The motion alarm must sound.

Figure 170



Slightly move both travel control levers in the forward direction (until the machine is slowly moving forward) and then press the motion alarm cancel switch (Item 1) [Figure 170]. The motion alarm will shut off. With the machine still moving forward, move both of the levers to the NEUTRAL position, the motion alarm must sound.

Slightly move both travel control levers in the reverse direction (until the machine is slowly moving backward) and then press the motion alarm cancel switch (Item 1) [Figure 170] (the switch icon will be illuminated when the motion alarm is deactivated). The motion alarm will shut off. With the machine still moving backward, move one of the levers to the NEUTRAL position, the motion alarm must sound.

Return both levers to NEUTRAL and turn excavator key to OFF position. Exit the excavator. (See STOPPING THE ENGINE AND LEAVING THE EXCAVATOR on Page 76.)

MOTION ALARM SYSTEM (CONT'D)

Inspecting (Cont'd)

The motion alarm is mounted to the bottom rear of the excavator. (To the front of the engine oil pan.)

Figure 171

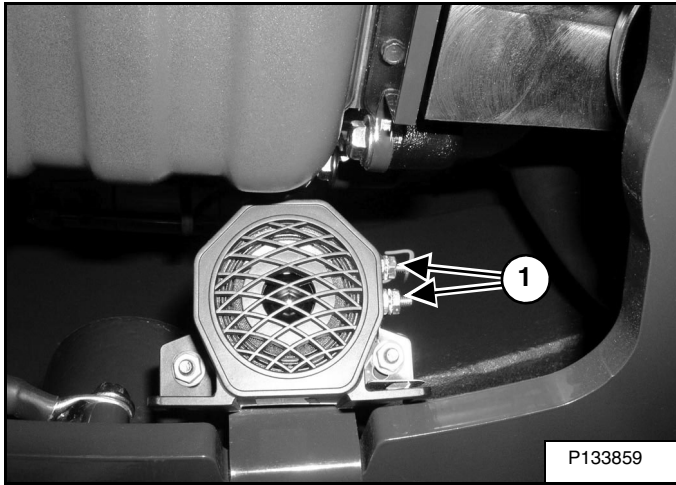

Inspect the motion alarm electrical connections (Item 1) [Figure 171], wire harness, and motion alarm switch (Item 1) [Figure 172] for tightness and damage. Repair or replace any damaged components.

If the motion alarm switch requires adjustment, see the following information.



**This machine is equipped with a motion alarm.
ALARM MUST SOUND!
when operating forward or backward.**

Failure to maintain a clear view in the direction of travel could result in serious injury or death.

The operator is responsible for the safe operation of this machine.

W-2786-0309

Adjusting Switch Position

The motion alarm switch (Item 1) [Figure 172] is located in the travel control valve located under the floorplate. Remove the floor mat and the floorplate. (See the Service Manual for the correct procedure.)

Remove the travel levers.

Figure 172

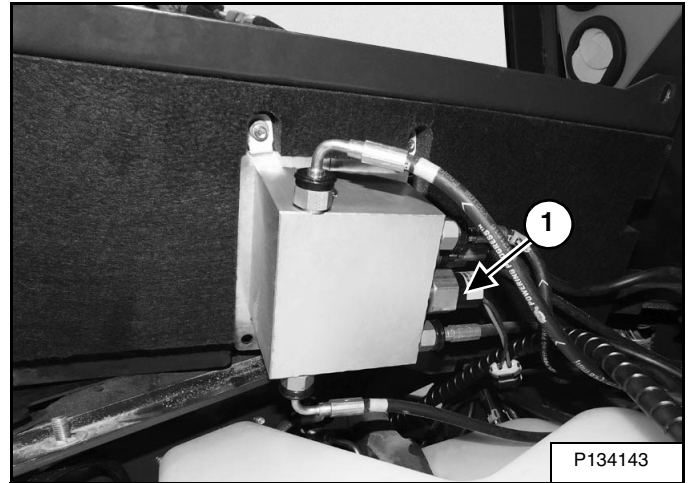

The switch (Item 1) [Figure 172] is non-adjustable. It must be fully installed into the travel control valve housing and tightened. Tighten the switch to 18 – 20 N•m (13 – 15 ft-lb).

Inspect the motion alarm system for proper function after switch replacement.

TAILGATE

Opening And Closing

! WARNING

AVOID INJURY OR DEATH

Never service or adjust the machine when the engine is running unless instructed to do so in the manual.

W-2012-0497

! WARNING

Keep the rear door closed when operating the machine. Failure to do so could seriously injure a bystander.

W-2020-1285

Figure 173

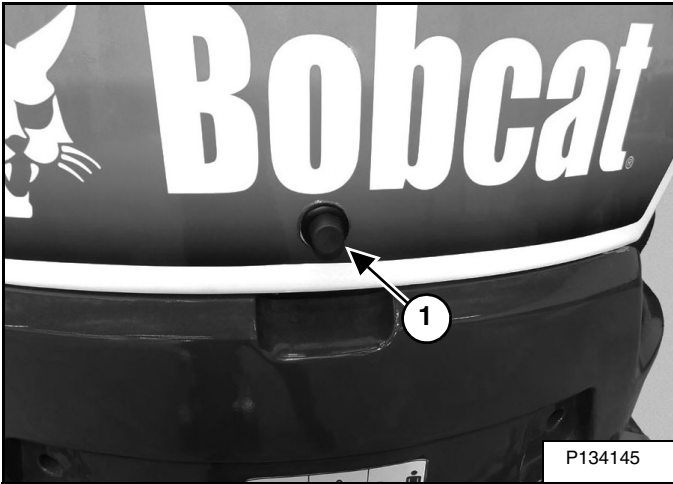

Push the button (Item 1) [Figure 173] and pull the tailgate up.

Push firmly to close the tailgate.

Adjusting The Latch

Figure 174

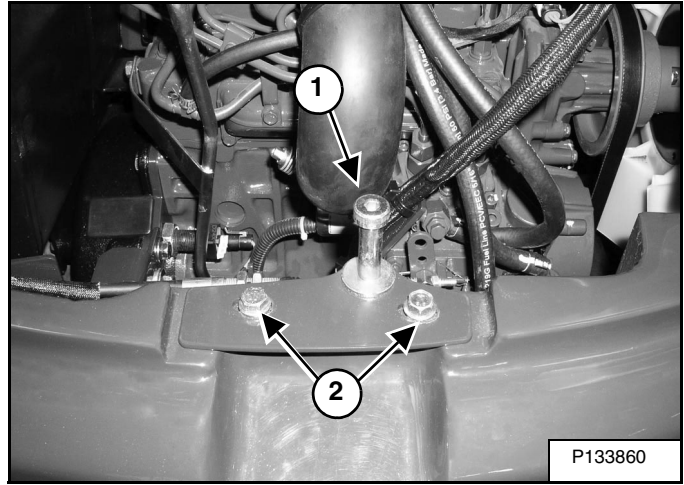

The tailgate latch (Item 1) [Figure 174] can be adjusted by loosening the two bolts (Item 2) [Figure 174], moving the latch, and tightening the two bolts.

Close the tailgate before operating the excavator.

RIGHT SIDE COVER

Opening And Closing

WARNING

AVOID INJURY OR DEATH

Never service or adjust the machine when the engine is running unless instructed to do so in the manual.

W-2012-0497

WARNING

Keep the rear door closed when operating the machine. Failure to do so could seriously injure a bystander.

W-2020-1285

Figure 175

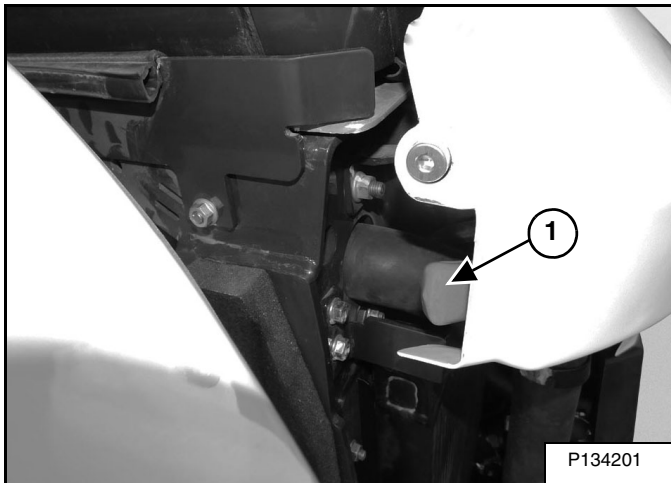

Open the tailgate to access the right side cover latch (Item 1) [Figure 175].

Figure 176



Pull the latch (Item 1) [Figure 175] toward the cover and lift the cover up (Item 1) [Figure 176].

To close the right side cover, rotate the cover back until it is in the fully closed position and you hear the latch (Item 1) [Figure 175] snap into place.

RIGHT SIDE PANEL

Removing And Reinstalling

Figure 177

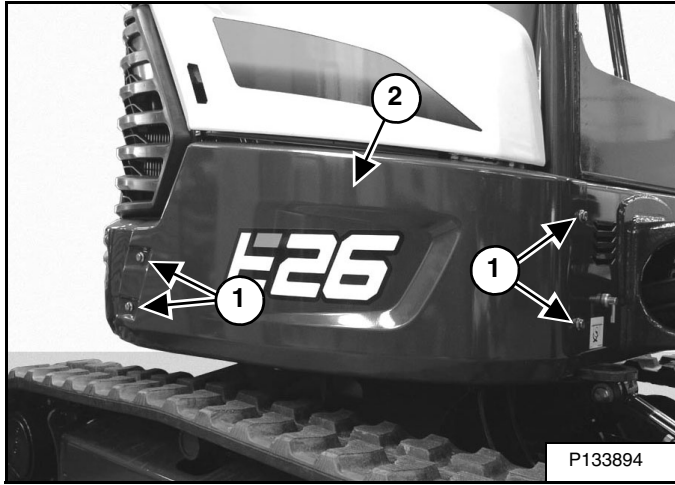

Remove the four bolts (Item 1) to remove the right side panel (Item 2) [Figure 177].

Reinstall the four bolts (Item 1) to reinstall the right side panel (Item 2) [Figure 177].

CAB FILTERS

Cleaning And Maintenance

The recirculation filter and the fresh air filter must be cleaned regularly. (See SERVICE SCHEDULE on Page 108.)

The recirculation filter is located to the right of the operator seat and the fresh air filter is located under the right side cover.

Recirculation Filter

Figure 178

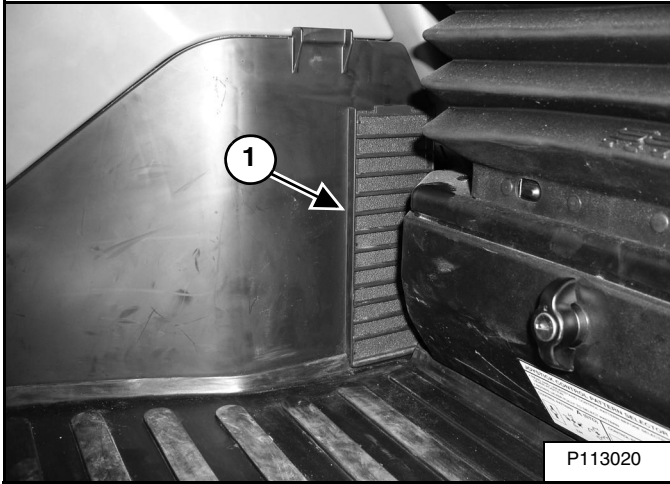

The recirculation filter (Item 1) [Figure 178] is located to the right of the operator's seat.

Figure 179

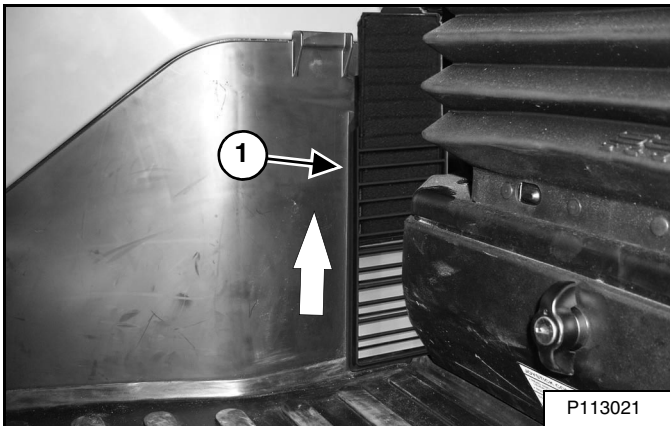

Pull up on the filter (Item 1) [Figure 179] until it is removed from the housing.

Shake the filter or use low pressure air to clean the filter. Replace the filter if it is very dirty or damaged.

Installation: Position the bottom of the filter (Item 1) [Figure 179] into the housing and slowly push the filter down fully.

Fresh Air Filter

Figure 180

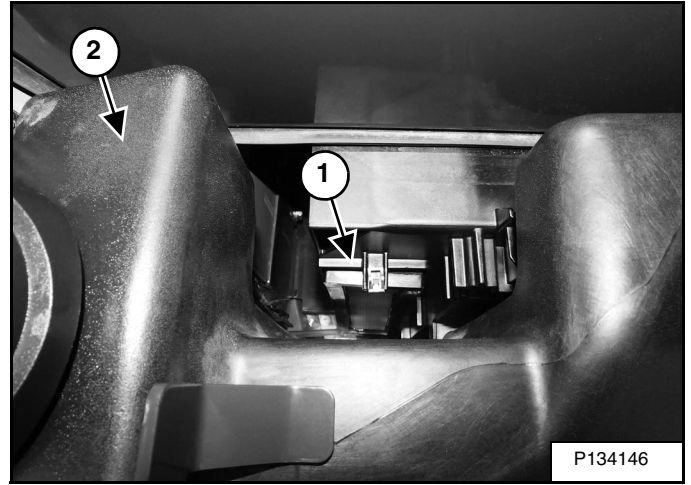

The fresh air filter (Item 1) is located behind the hydraulic tank (Item 2) [Figure 180] (view from the top).

Open the right side cover. (See RIGHT SIDE COVER on Page 115.)

Pull out on the tab (Item 1) [Figure 180] and remove the cover.

Pull the filter out of the housing.

Shake the filter or use low pressure air to clean the filter. Do not use solvents. Replace the filter when very dirty or damaged.

Installation: Position the filter into the housing and slowly push the filter in fully.

Place the bottom tabs of the filter cover into the frame and push the top in until the tab locks to the frame.

HEATING AND VENTILATION

Cleaning And Maintenance

The inside of the heater housing needs to be cleaned regularly. Dust will accumulate over time inside the housing. A dusty heater coil will reduce heating efficiency. (See SERVICE SCHEDULE on Page 108.)

The heater housing is located to the right of the operator seat.

Figure 181

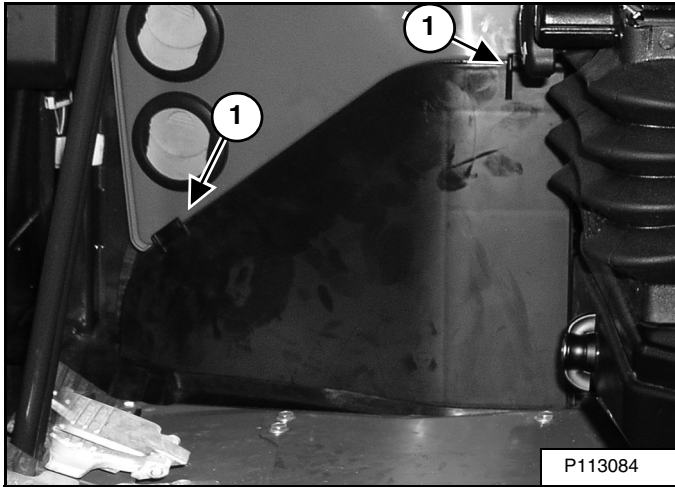

Remove the floor mat.

Pull back on the two latches (Item 1) [Figure 181] and remove the HVAC side cover.

To allow water to drain from the heater housing during the cleaning process, it is recommended to rotate the upperstructure 90° to the right. Then using the blade, raise the front of the excavator to allow water to run out of the housing. Use jackstands to support the front of the undercarriage.

Figure 182

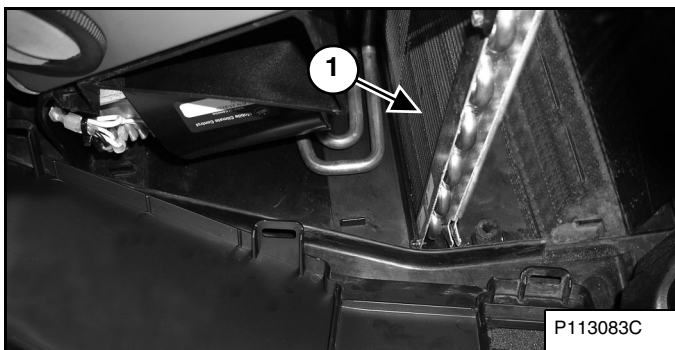

Use a lower pressure air or a low pressure water stream to remove debris and to clean the coils (Item 1) [Figure 182].

After the housing has been cleaned and flushed, remove the jackstands and raise the blade so the front of the excavator is flat on the ground. Stop the engine.

There are three rubber drain valves that allow condensation to drain from the housing during normal usage. These drain valve can get clogged with dirt and should be cleaned at the same time the housing is cleaned.

Two of the drain valves can be accessed from the right side cover (the drain valves are located below the heater housing on the right side) and one of the valves is located below the left rear corner of the heater housing and is accessed by removing the center floorplate.

Pinch the three rubber drain valves on the flat sides to open the valves and allow dirt and moisture to exit from the end of the valves.

Reinstall the center floorplate and close the right side cover.

Figure 183

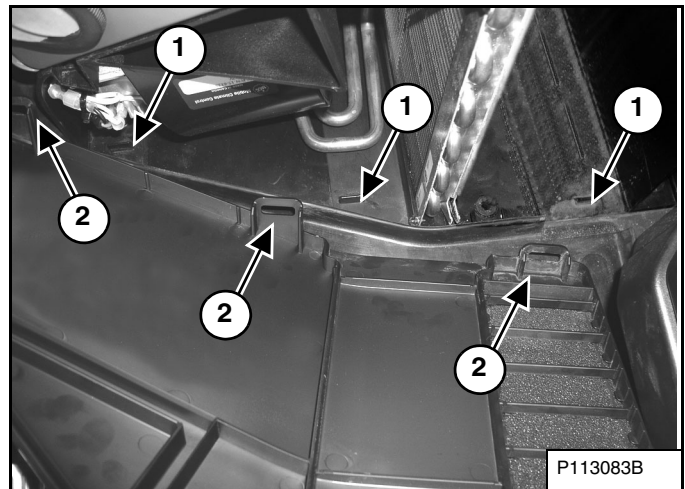

NOTE: The floor mat needs to be removed to allow easier access for installing the heater side cover.

Three tabs (Item 1) are on the bottom of the heater housing that the side cover retainers (Item 2) [Figure 183] fit into.

Position the side cover on the tabs and starting with the front edge of the side cover, position it into the front of the heater housing. Press on the front of the cover to secure the front latch (Item 1) [Figure 181]. Then press in on the top edge of the side cover and work back to the rear of the cover and secure the rear latch.

Reinstall the floor mat.

AIR CLEANER SERVICE

See the SERVICE SCHEDULE for the correct service interval. (See SERVICE SCHEDULE on Page 108.)

Open the tailgate. (See TAILGATE on Page 114.)

Figure 184

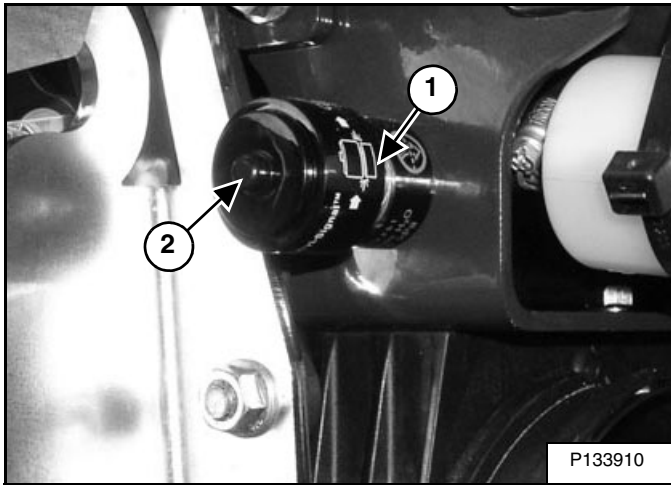

Check the condition indicator (Item 1) [Figure 184]. If the red ring shows in the condition indicator, the filter needs to be replaced.

Replace the inner filter every third time the outer filter is replaced or as indicated.

Replacing The Filter Elements

Outer Filter

Figure 185

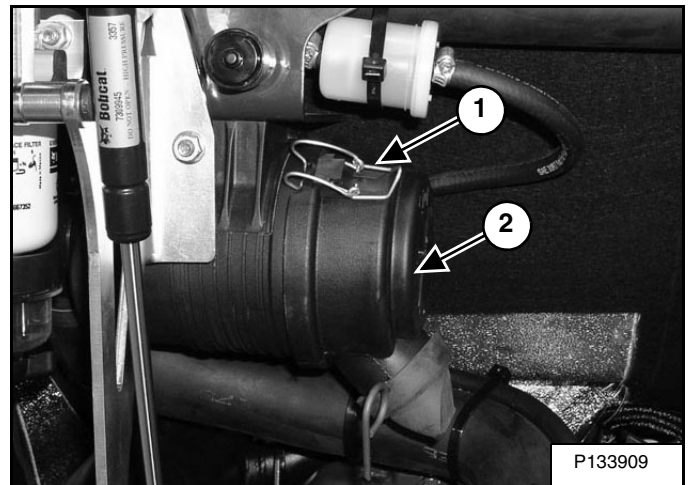

Open the two latches (Item 1) [Figure 185].

Remove and clean the dust cover (Item 2) [Figure 185].

Figure 186

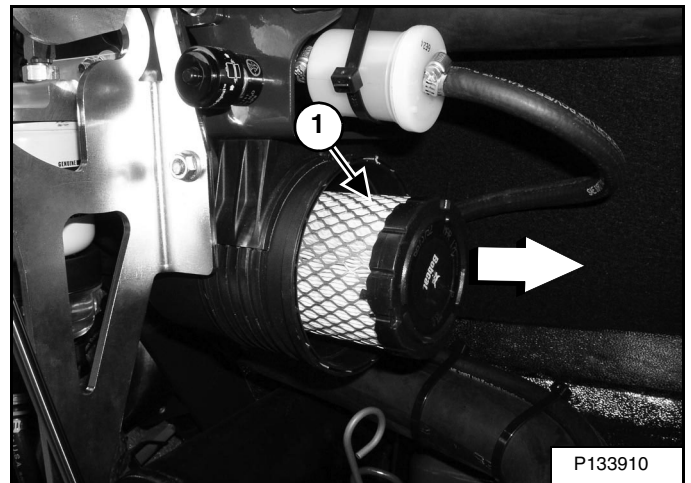

Pull the outer filter (Item 1) [Figure 186] from the air cleaner housing.

Check the housing for damage.

Clean the housing and the seal surface. DO NOT use compressed air.

Install a new filter.

AIR CLEANER SERVICE (CONT'D)

Replacing The Filter Elements (Cont'd)

Outer Filter (Cont'd)

Figure 187

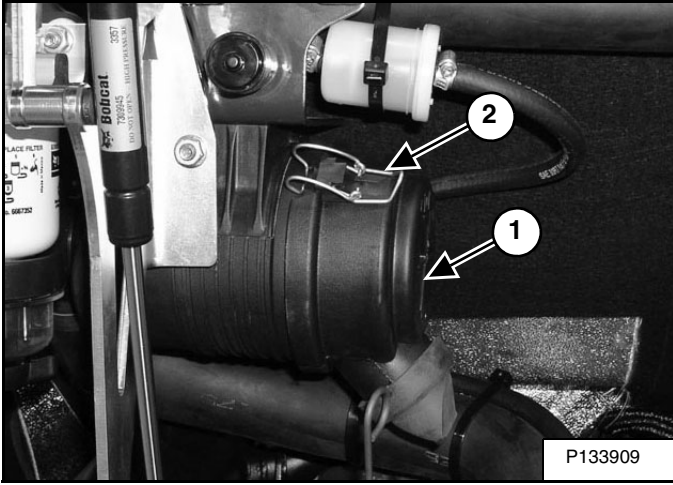

Install the dust cover (Item 1) [Figure 187].

Make sure the dust cover is installed and engage the latches (Item 2) [Figure 187].

Check the air intake hose and the air cleaner housing for damage. Make sure all connections are tight.

After the outer filter has been replaced, press the button (Item 2) [Figure 184] on the end of the condition indicator.

Start the engine. (See STARTING THE ENGINE on Page 71.) Run at full rpm, then reduce engine speed. Stop the engine. (See STOPPING THE ENGINE AND LEAVING THE EXCAVATOR on Page 76.)

If the red ring (Item 1) [Figure 184] shows in the condition indicator, replace the inner filter.

Inner Filter

Only replace the inner filter under the following conditions:

- Replace the inner filter every *third* time the outer filter is replaced.
- After the outer filter has been replaced, press the button (Item 2) [Figure 184] on the condition indicator. Start the engine and run at full rpm, then reduce engine speed. Stop the engine. If the red ring shows in the condition indicator, replace the inner filter.

Figure 188

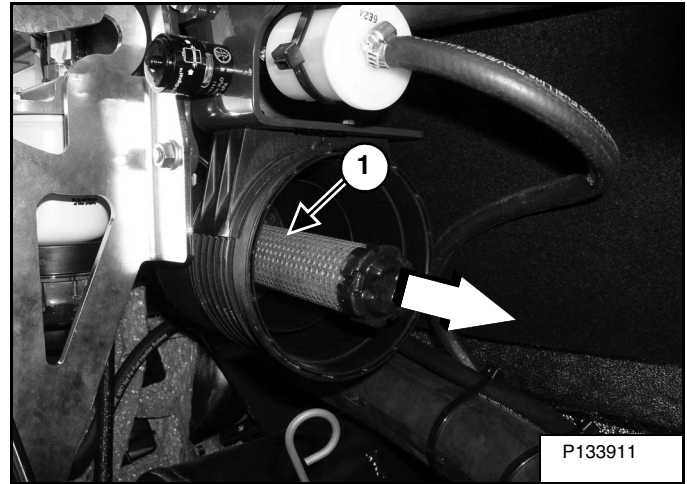

Remove the dust cover, outer filter and inner filter (Item 1) [Figure 188].

NOTE: Make sure all sealing surfaces are free of dirt and debris.

Install the new inner filter.

Install the outer filter and the dust cover.

Press the button (Item 2) [Figure 184] on the end of the condition indicator to remove the red ring.

Close the tailgate.

FUEL SYSTEM

Fuel Specifications

NOTE: Contact your local fuel supplier to receive recommendations for your region.

U.S. Standard (ASTM D975)

Use only clean, high quality diesel fuel, Grade Number 2-D or Grade Number 1-D.

Ultra low sulfur diesel fuel must be used in this machine. Ultra low sulfur is defined as 15 mg/kg (15 ppm) sulfur maximum.

The following is one suggested blending guideline that should prevent fuel gelling during cold temperatures:

TEMPERATURE	GRADE 2-D	GRADE 1-D
Above -9°C (+15°F)	100%	0%
Down to -21°C (-5°F)	50%	50%
Below -21°C (-5°F)	0%	100%

NOTE: Biodiesel blend fuel may also be used in this machine. Biodiesel blend fuel must contain no more than five percent biodiesel mixed with ultra low sulfur petroleum based diesel. This biodiesel blend fuel is commonly marketed as B5 blended diesel fuel. B5 blended diesel fuel must meet ASTM specifications.

E.U. Standard (EN590)

Use only clean, high quality diesel fuel that meets the EN590 specifications listed below:

- Ultra low sulfur diesel fuel defined as 10 mg/kg (10 ppm) sulfur maximum
- Diesel fuel with cetane number of 51.0 and above.

NOTE: Biodiesel blend fuel may also be used in this machine. Biodiesel blend fuel must contain no more than seven percent biodiesel mixed with ultra low sulfur petroleum based diesel. This biodiesel blend fuel is commonly marketed as B7 blended diesel fuel. B7 blended diesel fuel must meet EN590 specifications.

Biodiesel Blend Fuel

Biodiesel blend fuel has unique qualities that should be considered before using in this machine:

- Cold weather conditions can lead to plugged fuel system components and hard starting.
- Biodiesel blend fuel is an excellent medium for microbial growth and contamination which can cause corrosion and plugging of fuel system components.
- Use of biodiesel blend fuel may result in premature failure of fuel system components, such as plugged fuel filters and deteriorated fuel lines.
- Shorter maintenance intervals may be required, such as cleaning the fuel system and replacing fuel filters and fuel lines.
- Using biodiesel blended fuels containing more than five percent biodiesel can affect engine life and cause deterioration of hoses, tubelines, injectors, injector pump and seals.

Apply the following guidelines if biodiesel blend fuel is used:

- Ensure the fuel tank is as full as possible at all times to prevent moisture from collecting in the fuel tank.
- Ensure that the fuel tank cap is securely tightened.
- Biodiesel blend fuel can damage painted surfaces, remove all spilled fuel from painted surfaces immediately.
- Drain all water from the fuel filter daily before operating the machine.
- Do not exceed engine oil change interval. Extended oil change intervals can cause engine damage.
- Before vehicle storage; drain the fuel tank, refill with 100% petroleum diesel fuel, add fuel stabilizer and run the engine for at least 30 minutes.

NOTE: Biodiesel blend fuel does not have long-term stability and should not be stored for more than three months.

FUEL SYSTEM (CONT'D)

Filling The Fuel Tank

WARNING

FIRE AND EXPLOSION HAZARD

Failure to obey instructions can cause serious injury or death.

Shut down the machine and allow it to cool before adding fuel. **NO SMOKING!**

W-2063-0425

WARNING

FIRE AND EXPLOSION HAZARD

Failure to use care around combustibles can cause serious injury or death.

Always clean up spilled flammable fluids or oil. Keep heat, flames, sparks or lighted tobacco away from flammable fluids and oil.

W-2103-0824

Figure 189



Use the start key to unlock the fuel cap.

Remove the fuel fill cap (Item 1) [Figure 189].

Use a clean, approved safety container to add fuel. Add fuel only in an area that has a free movement of air and no flames or sparks. **NO SMOKING!**

Install and tighten the fuel fill cap.

Clean up any spilled fuel.

See the SERVICE SCHEDULE for the service interval when to remove water from or replace the fuel filter. (See SERVICE SCHEDULE on Page 108.)

FUEL SYSTEM (CONT'D)

Fuel Filters

Removing Water

Open the tailgate. (See TAILGATE on Page 114.)

Figure 190

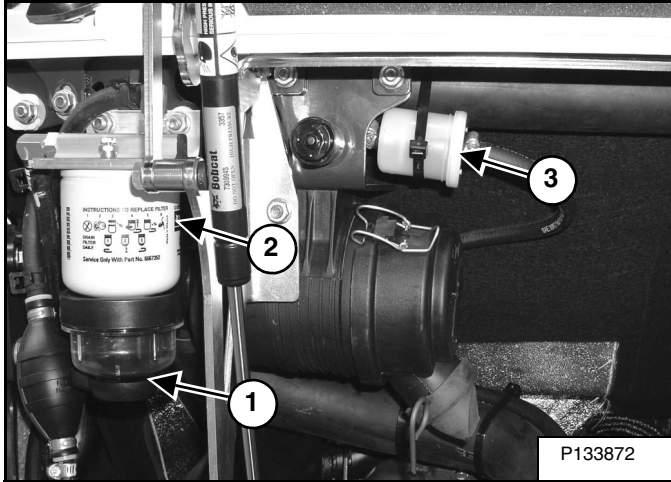

Loosen the drain (Item 1) [Figure 190] at the bottom of the filter (Item 2) [Figure 190] to drain water from the filter into a container.

Inspect the fuel pre-filter (Item 3) [Figure 190] daily for moisture and contamination. Replace as necessary.

Clean up any spilled fuel.

Replacing Elements

Remove and replace the fuel pre-filter (Item 3) [Figure 190].

Remove the filter (Item 2) [Figure 190].

Clean the area around the filter housing. Put clean oil on the seal of the new filter. Install the fuel filter and hand tighten.

Remove the air from the fuel system. (See Removing Air From The Fuel System on Page 124.)

Close the tailgate.

Draining The Fuel Tank

See the SERVICE SCHEDULE for the correct service interval. (See SERVICE SCHEDULE on Page 108.)

Figure 191



Rotate the upperstructure so that the fuel tank drain plug (Item 1) is located between the rear tracks.

Remove the drain plug (Item 1) [Figure 191].

Drain the fuel into the container.

Reuse, recycle or dispose of fuel in an environmentally safe manner.

Reinstall the drain plug.

WARNING

INJECTION HAZARD

Pressurized diesel fuel or hydraulic fluid can penetrate skin and eyes, causing serious injury or death.

Fluid leaks under pressure may not be visible. Use a piece of cardboard or wood to find leaks. DO NOT use your bare hand. Wear safety goggles. If fluid enters skin or eyes, get immediate medical attention from a doctor familiar with this injury.

W-2072-0824

FUEL SYSTEM (CONT'D)

Removing Air From The Fuel System

After replacing the fuel filter or when the fuel tank has run out of fuel, air must be removed from the fuel system before starting the engine.

Open the tailgate. (See TAILGATE on Page 114.)

Figure 192

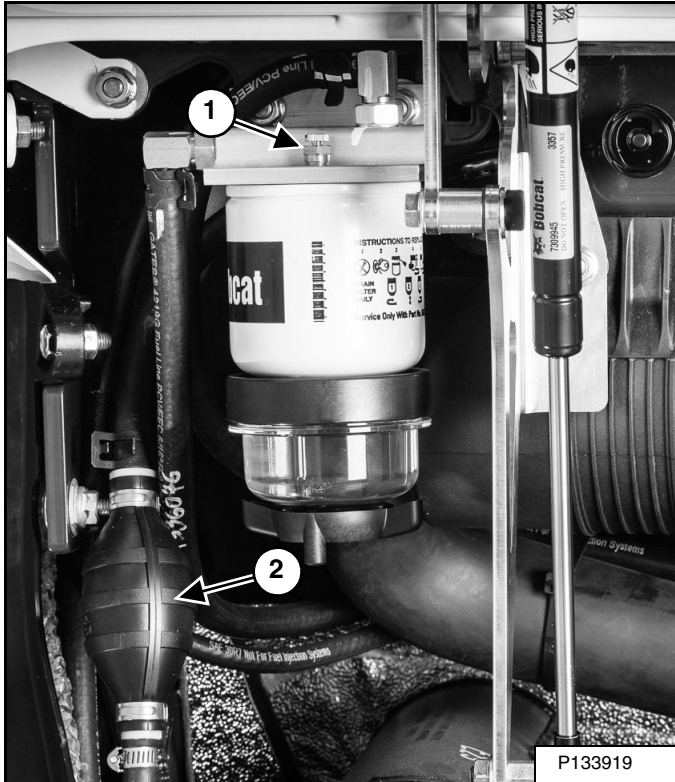

Open the fuel filter vent (Item 1) [Figure 192] and operate the hand pump (priming bulb) (Item 2) [Figure 192] until the fuel flows from the vent with no air bubbles.

Close the vent (Item 1) [Figure 192].

Figure 193

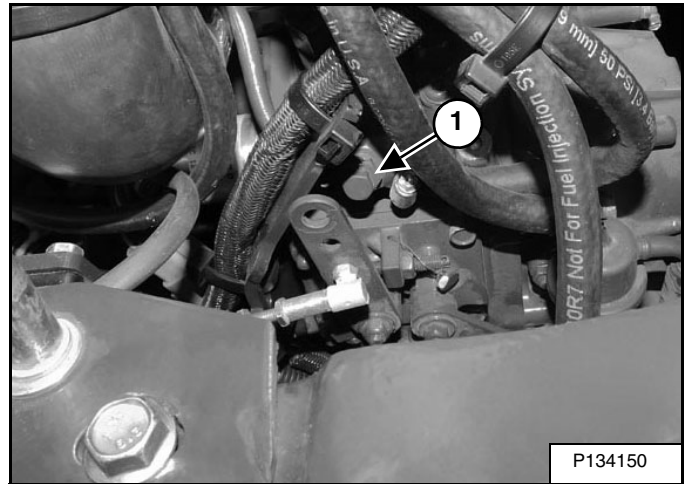

Start the engine. It can be necessary to open the vent (Item 1) [Figure 193] (at the fuel injection pump) briefly until the engine runs smoothly.

Close the tailgate.

WARNING

INJECTION HAZARD

Pressurized diesel fuel or hydraulic fluid can penetrate skin and eyes, causing serious injury or death.

Fluid leaks under pressure may not be visible. Use a piece of cardboard or wood to find leaks. **DO NOT** use your bare hand. Wear safety goggles. If fluid enters skin or eyes, get immediate medical attention from a doctor familiar with this injury.

W-2072-0824

ENGINE LUBRICATION SYSTEM

Checking And Adding Engine Oil

Check the engine oil after every 8 – 10 hours of operation and before starting the engine. (See SERVICE SCHEDULE on Page 108.)

Figure 194

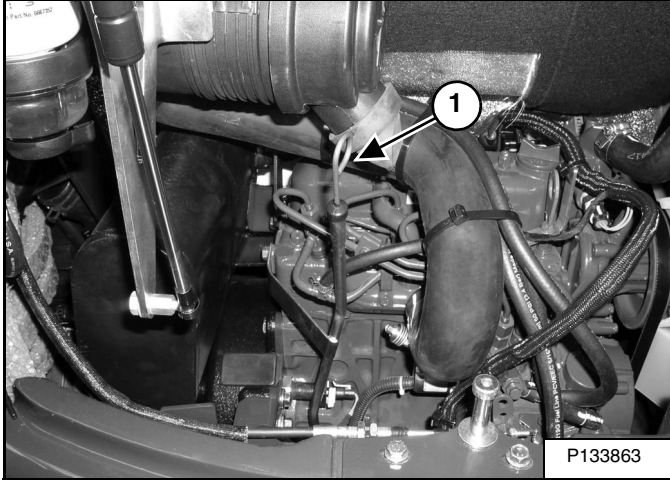

Open the tailgate and remove the dipstick (Item 1) [Figure 194].

Keep the oil level between the marks on the dipstick.

Use a good quality motor oil that meets the correct API Service Classification.

Close the tailgate.

Engine Oil Chart

Figure 195

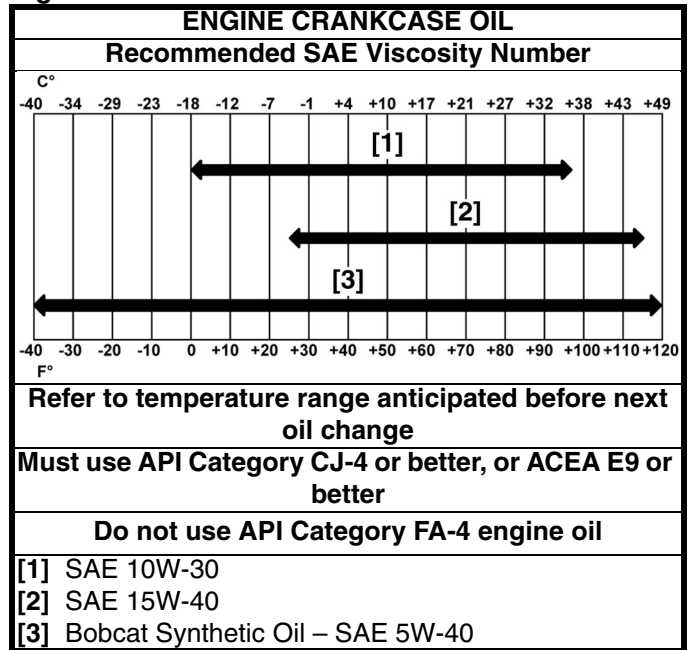

Bobcat engine oils are recommended for use in this machine. If Bobcat engine oil is not available, use a good quality engine oil that meets API Service Category of CJ-4 or better, or ACEA E9 or better [Figure 195].

! WARNING

FIRE AND EXPLOSION HAZARD

Failure to use care around combustibles can cause serious injury or death.

Always clean up spilled flammable fluids or oil. Keep heat, flames, sparks or lighted tobacco away from flammable fluids and oil.

W-2103-0824

ENGINE LUBRICATION SYSTEM (CONT'D)

Removing And Replacing Oil And Filter

See the SERVICE SCHEDULE for the service interval for replacing the engine oil and filter. (See SERVICE SCHEDULE on Page 108.)

Run the engine until it is at operating temperature. Stop the engine.

Open the tailgate. (See TAILGATE on Page 114.)

Figure 196

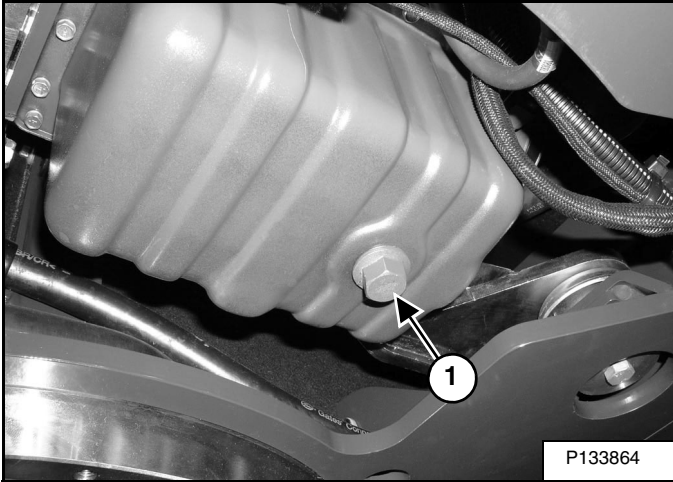

Place a container under the oil pan. Remove the drain plug (Item 1) [Figure 196] from the bottom of the engine oil pan.

Recycle or dispose of used oil in an environmentally safe manner.

Figure 197

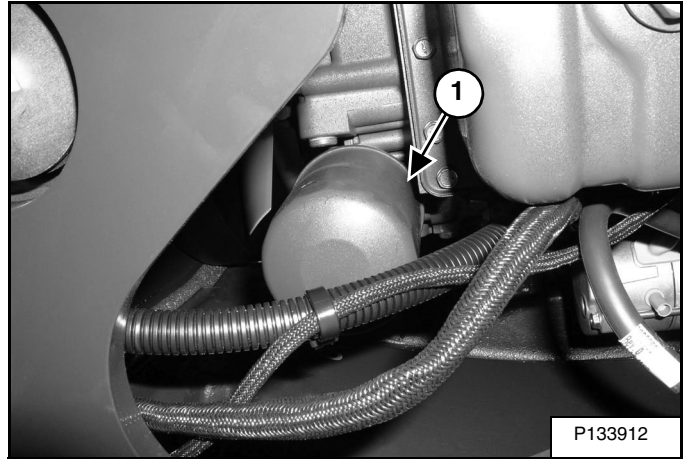

Remove the oil filter (Item 1) [Figure 197] and clean the filter housing surface.

Use a genuine Bobcat replacement filter. Put clean oil on the filter gasket. Install the filter and hand tighten.

Install and tighten the drain plug (Item 1) [Figure 196].

Figure 198



Remove the fill cap (Item 1) [Figure 198].

Put oil in the engine. (See Engine Oil Chart on Page 125.)

Install the fill cap (Item 1) [Figure 198].

Start the engine and let it run for several minutes.

Stop the engine. Check for leaks at the oil filter. Check the oil level.

Add oil as needed if it is not at the top mark on the dipstick.

Close the tailgate.

ENGINE COOLING SYSTEM

Cleaning

Check the cooling system every day to prevent overheating, loss of performance or engine damage. (See SERVICE SCHEDULE on Page 108.)

NOTE: Allow the cooling system and engine to cool before servicing or cleaning the cooling system.

Open the tailgate. (See TAILGATE on Page 114.)

Open the right side cover. (See RIGHT SIDE COVER on Page 115.)

Figure 199

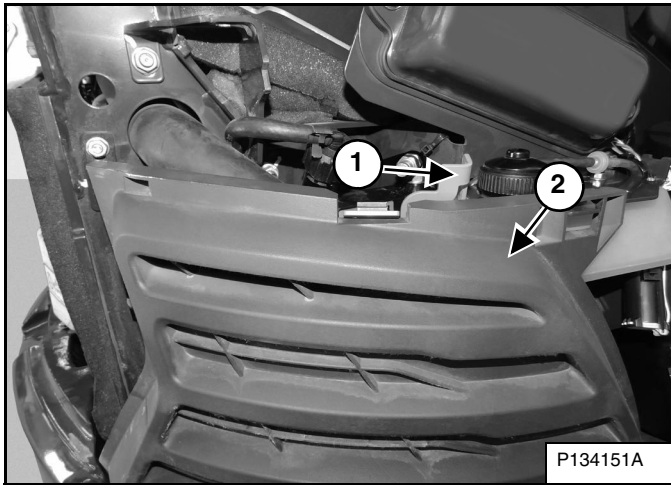

Push the lever (Item 1) and remove the rear side cover (Item 2) [Figure 199].

Figure 200

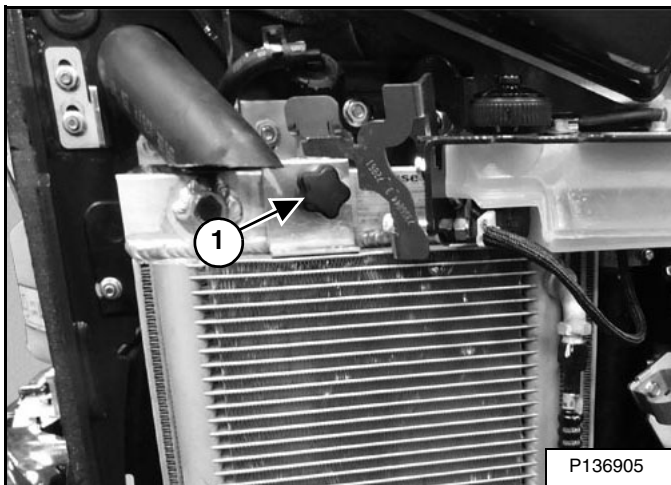

Unscrew the knob (Item 1) [Figure 200] and remove it.

Figure 201

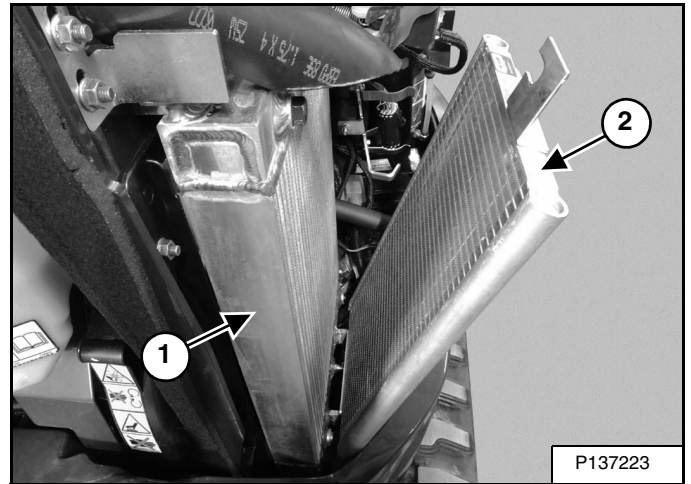

Pull the condenser (Item 2) away from the radiator (Item 1) [Figure 201]. Use low air pressure or water pressure to clean the radiator and condenser (both inside and outside surfaces). Be careful not to damage fins when cleaning.

Slide the knob (Item 1) [Figure 200] back through the condenser and radiator until it is fully seated in the slots of the mounting brackets. Tighten the knob. Be careful not to damage fins.

Reinstall the rear side cover (Item 2) by sliding the bottom into place and snapping the top back into the lever (Item 1) [Figure 199].

Close the right side cover and tailgate.

Coolant Types

Your machine was factory filled with one of these two coolants. Before refilling or replacing coolant, identify the coolant by color:

- Propylene Glycol (PG) is purple.
- Ethylene Glycol (EG) is red.

If coolant cannot be identified by color, drain coolant completely and refill tank with Bobcat EG Coolant Premix.

When adding coolant to the tank, add the same type of coolant. Do not mix different types of coolants.

To switch between different types of coolants, first completely drain existing coolant.

ENGINE COOLING SYSTEM (CONT'D)

Coolant Concentration

Bobcat Company recommends using pre-mixed coolant. If you choose to mix it yourself, use the following concentrations.

Ethylene Glycol (EG) Concentration

The correct mixing ratio of propylene glycol (PG) is 47% distilled water or deionized water and 53% PG. This will provide -37°C (-34°F) freeze protection. Mix 3,8 L (1 U.S. gal) PG concentrate with 3,3 L (3.5 qt) distilled water to obtain this ratio.

Propylene Glycol (PG) Concentration

The correct mixing ratio of ethylene glycol (EG) is 50% distilled water or deionized water and 50% EG. This will provide -37°C (-34°F) freeze protection. Mix 3,8 L (1 U.S. gal) EG concentrate with 3,8 L (1 U.S. gal) distilled water to obtain this concentration.

Checking Level

WARNING

BURN HAZARD

Failure to follow instructions can cause serious burns.

Stop the engine and allow it to cool before removing the radiator cap or adding coolant.

W-2070-0824

WARNING

AVOID INJURY OR DEATH

Wear safety glasses to prevent eye injury when any of the following conditions exist:

- When fluids are under pressure.
- Flying debris or loose material is present.
- Engine is running.
- Tools are being used.

W-2019-0907

Open the tailgate. (See TAILGATE on Page 114.)

Figure 202

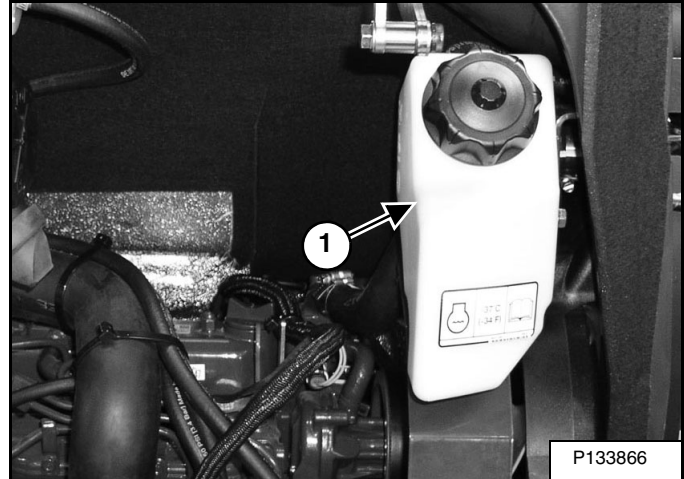

Check the coolant level in the coolant recovery tank (Item 1) [Figure 202].

The coolant level must be filled to the COLD FILL line marked on the on the coolant recovery tank. (See Coolant Types on Page 127.) and (See Coolant Concentration on Page 128.)

Close the tailgate.

IMPORTANT

AVOID ENGINE DAMAGE

Always use the correct ratio of water to antifreeze.

Too much antifreeze reduces cooling system efficiency and may cause serious premature engine damage.

Too little antifreeze reduces the additives which protect the internal engine components; reduces the boiling point and freeze protection of the system.

Always add a premixed solution. Adding full strength concentrated coolant can cause serious premature engine damage.

I-2124-0497

ENGINE COOLING SYSTEM (CONT'D)

Removing And Replacing Coolant

See the SERVICE SCHEDULE for correct service intervals. (See SERVICE SCHEDULE on Page 108.)

WARNING

BURN HAZARD

Failure to follow instructions can cause serious burns.

Stop the engine and allow it to cool before removing the radiator cap or adding coolant.

W-2070-0824

NOTE: Allow the cooling system and engine to cool before servicing or cleaning the cooling system.

Stop the engine. Open the tailgate. (See TAILGATE on Page 114.)

Open the right side cover. (See RIGHT SIDE COVER on Page 115.)

Push down on the lever (Item 1) and remove the rear side cover (Item 2) [Figure 199].

Figure 203

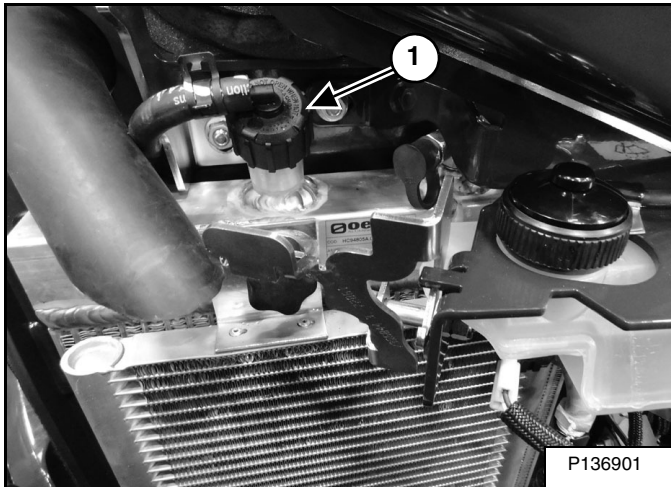

When the engine is cool, loosen and remove the coolant fill cap (Item 1) [Figure 203].

Figure 204

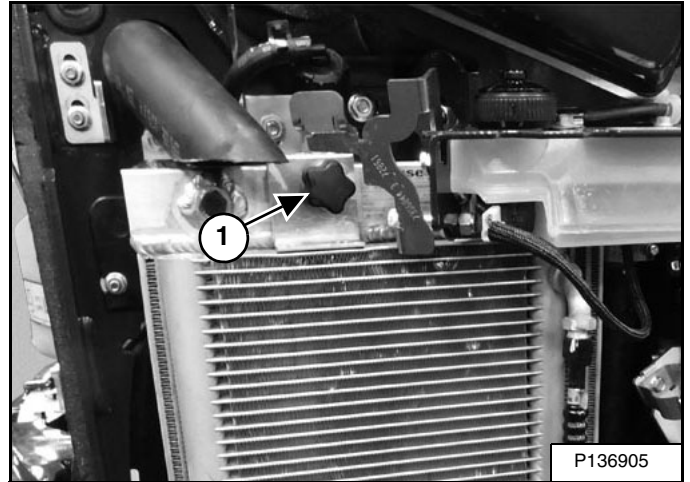

Unscrew the knob (Item 1) [Figure 204] and remove it.

Figure 205

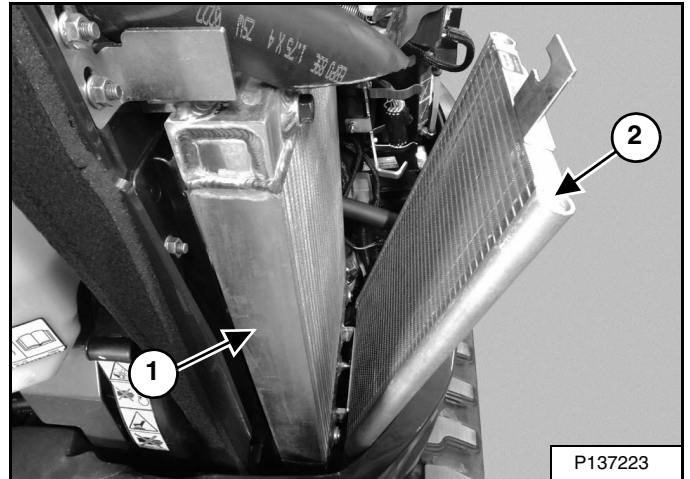

Pull the condenser (Item 2) away from the radiator (Item 1) [Figure 205].

ENGINE COOLING SYSTEM (CONT'D)

Removing And Replacing Coolant (Cont'd)

Figure 206

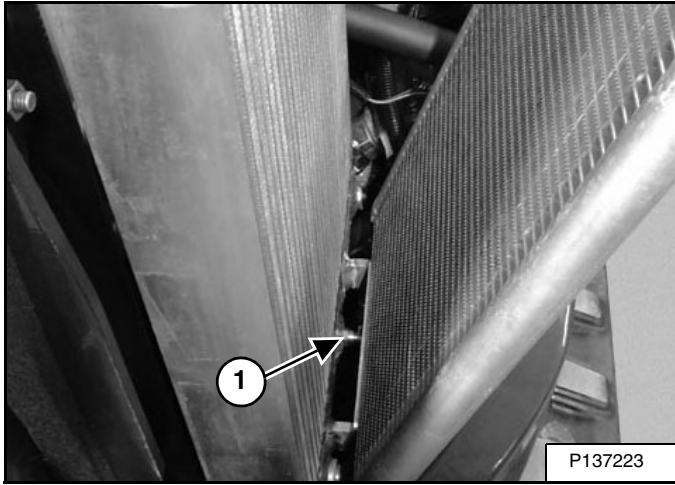

Put a hose on the drain valve at the bottom of the radiator (Item 1) **[Figure 206]**. Open the drain valve and drain the coolant into a container.

After all the coolant is removed, close both drain valves. Remove the drain hose from the engine drain valve.

Slide the knob (Item 1) **[Figure 204]** back through the condenser and radiator until it is fully seated in the slots of the mounting brackets. Tighten the knob. Be careful not to damage fins.

Recycle or dispose of the used coolant in an environmentally safe manner.

Identify the type of engine coolant in the machine. (See Coolant Types on Page 127.)

Add premixed coolant to the radiator. (See Coolant Concentration on Page 128.)

Install the radiator cap (Item 1) **[Figure 203]**. Be sure the radiator cap is tight.

Add premixed coolant to the coolant tank until the coolant level reaches the middle of the "MAX COLD" and the "MIN COLD" level marks. (See Coolant Concentration on Page 128.)

Run the engine until it is at operating temperature. Stop the engine. Check the coolant level in the coolant tank.

Reinstall the rear side cover.

Close the right side cover and tailgate.

ELECTRICAL SYSTEM

Description

Figure 207

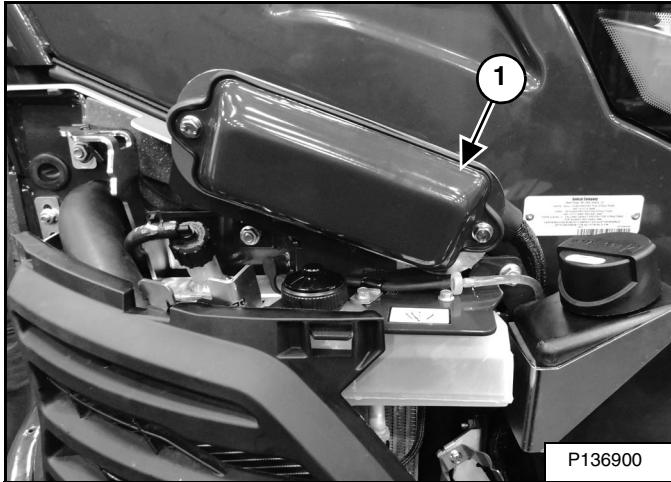

The excavator has a 12 volt, negative ground electrical system. The electrical system is protected by fuses located under the right side cover of the excavator (Item 1) [Figure 207]. The fuses will protect the electrical system when there is an electrical overload. The reason for the overload must be found and corrected before starting the engine again.

The battery cables must be clean and tight. Check the electrolyte level in the battery. Add distilled water as needed. Remove acid or corrosion from the battery and cables with a sodium bicarbonate and water solution.

Put Battery Saver P/N 6664458 or grease on the battery terminals and cable ends to prevent corrosion.

WARNING

CHEMICAL HAZARD

Contact with or ingestion of battery acid can cause serious injury or death.

- Batteries contain acid that burns eyes and skin on contact. Wear safety goggles, protective clothing, and rubber gloves to keep acid off body.
- In case of acid contact, wash immediately with water. In case of eye contact, get prompt medical attention and wash eye with clean, cool water for at least 5 minutes.
- If electrolyte is ingested, drink large quantities of water or milk! DO NOT induce vomiting. Get prompt medical attention.

W-2065-0824

Fuse And Relay Location / Identification

A decal is inside the fuse cover to show location and amp ratings.

Remove the cover to check or replace the fuses and relays.

The location and sizes are shown in [Figure 208].

Always replace fuses using the same type and capacity.

ELECTRICAL SYSTEM (CONT'D)

Fuse And Relay Location / Identification (Cont'd)

Figure 208

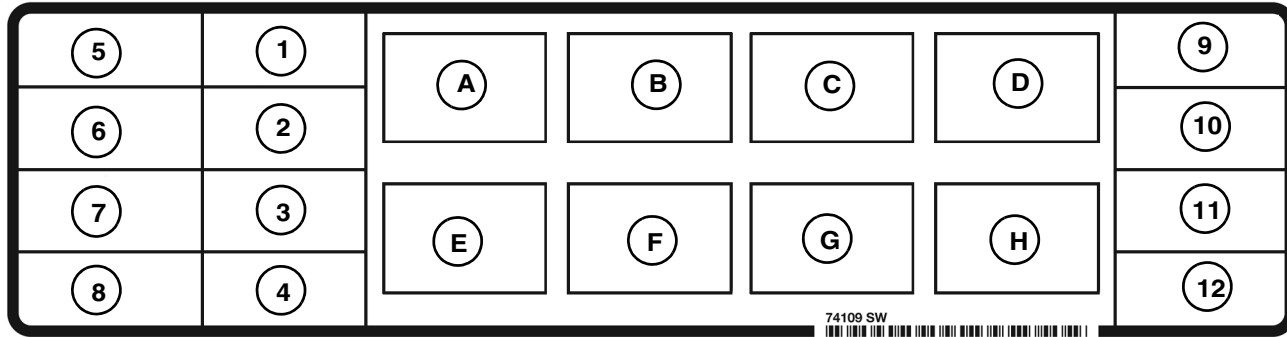

The location and sizes are shown in the table below and on the decal [Figure 208]. Relays are identified by the letter “R” in the AMP column.

REF	ICON	DESCRIPTION	AMP	REF	ICON	DESCRIPTION	AMP	REF	ICON	DESCRIPTION	AMP
1		Wiper / Washer	10	9		Panel / Display Controller	25	E		Fuel Shutoff	R
2		Switched Power	20	10		ACD Unswitched Power	25	F		Lights	R
3		Alternator Excite / Heater	25	11		Lights	30	G		Glow Plug	R
4		ACD Switched Power	25	12		Power Port	15	H		Starter	R
5		Auto Idle Controller (AIC) (if equipped)	20	A		Switched Power	R				
6		HVAC / Heater	40	B		Heater / HVAC	R				
7		Ignition	5	C		Lights	R				
8		Fuel Shutoff	25	D		Horn	R				

ELECTRICAL SYSTEM (CONT'D)

Fuse And Relay Location / Identification (Cont'd)

Figure 209

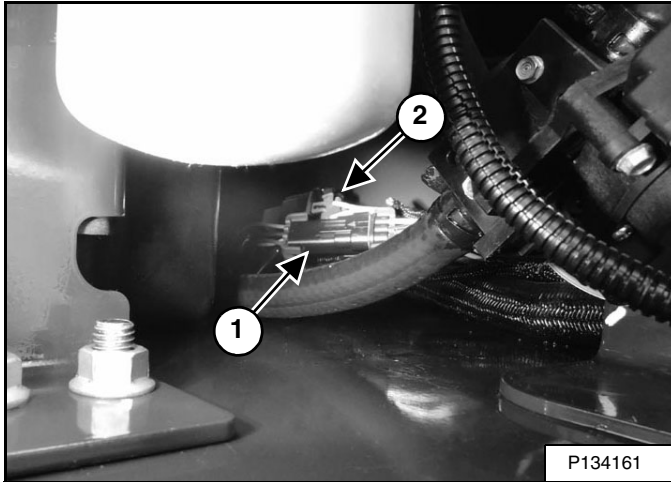

If the excavator is equipped with a motion alarm, there will be two relays located behind the case drain filter. The first (Item 1) is a back-up alarm relay for the motion alarm. The second (Item 2) [Figure 209] is a motion alarm relay.

ELECTRICAL SYSTEM (CONT'D)

Battery Maintenance

See the SERVICE SCHEDULE for the correct service interval. (See SERVICE SCHEDULE on Page 108.)

The Bobcat brand battery supplied with your machine is sealed and does not require watering. Proper charging and storage are important to maximize the life of all batteries.

Figure 210

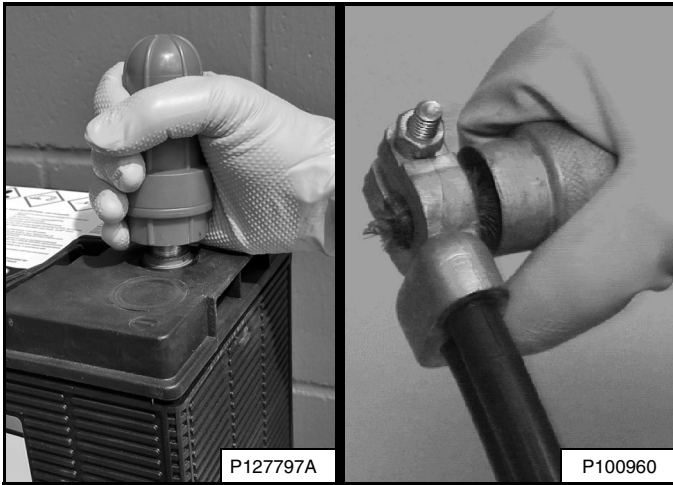

Simple steps for reliability and long battery life:

- Keep battery posts and terminals clean [Figure 210].
- Keep terminals tight.
- Remove corrosion from battery and terminals with sodium bicarbonate (baking soda) and water solution.
- Put Bobcat Battery Saver or grease on the battery terminals and cable ends to prevent corrosion.
- Operate the machine for at least 15 minutes to recover from the battery drain caused by engine start up whenever practical.
- Maintain the battery charge level. This is a key factor for long battery life.
- Charge a severely discharged battery with a battery charger instead of relying on the machine charging system. (See Battery Charging on Page 135.)
- Check the battery state of charge every 30 days on machines that are not frequently used. (See Battery Testing on Page 135.)



WARNING

CHEMICAL HAZARD

Contact with or ingestion of battery acid can cause serious injury or death.

- Batteries contain acid that burns eyes and skin on contact. Wear safety goggles, protective clothing, and rubber gloves to keep acid off body.
- In case of acid contact, wash immediately with water. In case of eye contact, get prompt medical attention and wash eye with clean, cool water for at least 5 minutes.
- If electrolyte is ingested, drink large quantities of water or milk! DO NOT induce vomiting. Get prompt medical attention.

W-2065-0824

Maintaining Battery Charge Level

All batteries will self-discharge over time. This machine has features that require battery power even when the machine is not being used. Use of a quality battery maintainer is highly recommended to ensure that your machine is ready to start when you need it and avoid costly battery replacement.

Battery Maintainers

Use a good quality battery maintainer to keep the battery above 12.4 volts for machines that are not frequently used. Batteries below 12.4 volts must first be charged using a battery charger. Solar maintainers should have a minimum capacity of 10 watts to be effective.

Battery Service During Machine Storage

Remove the battery if storing the machine for an extended period of time. Fully charge the battery. Store the battery in a cool dry place above freezing and boost charge periodically. If battery removal is not desired, a good quality battery maintainer must be used to compensate for battery self-discharge and parasitic loads from machine controllers, accessories, and features such as connected machine intelligence.

ELECTRICAL SYSTEM (CONT'D)

Battery Testing

Figure 211

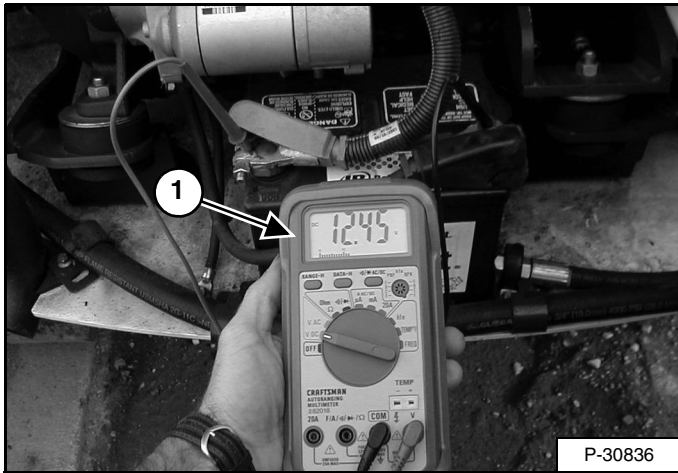

The simplest and most common check to determine battery state of charge is to use a digital multimeter or voltmeter (Item 1) [Figure 211].

A battery found below 12.4 volts must be charged to 100% charge per the battery charger's recommendation. **Allow at least 60 minutes after operating the machine or charging the battery to get an accurate reading.**

If the reading is less than 12.4 volts after the battery has been charged for several hours, see your Bobcat dealer to have a more thorough battery test performed.

The freezing point of battery electrolyte is dependent on the battery state of charge. Keeping the battery voltage above 12.4 volts will help prevent batteries from freezing, even at extremely low temperatures.

If the battery freezes, the internal grid may be damaged and the case will be distorted or cracked. If this happens, dispose of the battery according to local, state, and federal regulations.

Battery Charging

A battery charger designed for 12 volt charging systems is recommended. Follow the battery charger manufacturer's instructions to charge the battery to 12.6 volts (100% charge). Batteries should be charged at room temperature to avoid an undercharge or overcharge condition. Never attempt to charge a frozen battery.

The following table can be used to identify the approximate amount of time required to charge a discharged battery. Allow at least 60 minutes after operating the machine or charging the battery to get an accurate reading.

BATTERY VOLTAGE	STATE OF CHARGE	CHARGER MAXIMUM RATE		
		30 Amps	20 Amps	10 Amps
12.6 V	100%	READY TO USE		
12.4 V	75%	0.9 hr.	1.3 hr.	2.5 hr.
12.2 V	50%	1.9 hr.	2.7 hr.	5.1 hr.
12.0 V	25%	2.9 hr.	4.3 hr.	7.8 hr.
11.8 V	0%	4.0 hr.	5.7 hr.	10.7 hr.

NOTE: Use a good quality automatic charger to avoid battery damage from overcharging.

WARNING

EXPLOSION HAZARD

Battery gas can explode and cause serious injury or death.

- **Keep arcs, sparks, flames and lighted tobacco away from batteries. When jumping from booster battery make final connection (negative) at machine frame.**
- **Do not jump start or charge a frozen or damaged battery. Warm battery to 16°C (60°F) before connecting to a charger. Unplug charger before connecting or disconnecting cables to a battery. Never lean over battery while boosting, testing or charging.**

W-2066-0824

ELECTRICAL SYSTEM (CONT'D)

Using A Booster Battery (Jump Starting)

IMPORTANT

If jump starting the excavator from a second machine:

When jump starting the excavator from a battery installed in a second machine, make sure the engine is **NOT** running while using the glow plugs. High voltage spikes from a running machine can burn out the glow plugs.

I-2060-0906

If it is necessary to use a booster battery to start the engine, **BE CAREFUL!** There must be one person in the operator's seat and one person to connect and disconnect the battery cables.

Be sure the key switch is OFF. The booster battery must be 12 volt.

Open the tailgate. (See TAILGATE on Page 114.)

Open the right side cover. (See RIGHT SIDE COVER on Page 115.)

Remove the right side panel. (See RIGHT SIDE PANEL on Page 116.)

Remove the rear side cover (Item 2) [Figure 199].

Figure 212

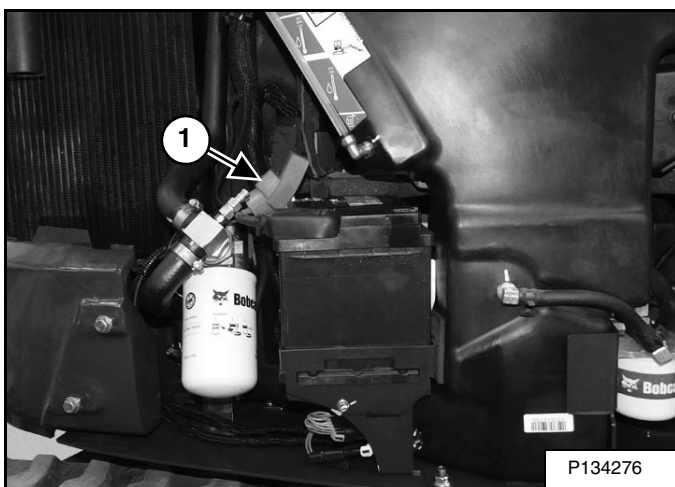

Remove the positive battery terminal cover (Item 1) [Figure 212].

Figure 213

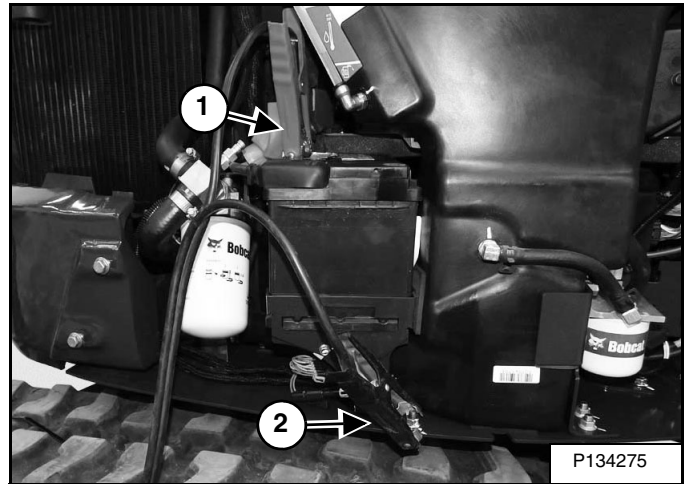

Connect one end of the first cable to the positive (+) terminal of the booster battery. Connect the other end of the same cable to the positive (+) terminal (Item 1) [Figure 213] of the excavator battery.

Connect one end of the second cable to the negative (-) terminal of the booster battery. Connect the other end of the same cable to a frame grounding point (Item 2) [Figure 213].

Start the engine. After the engine has started, remove the negative (-) cable first (Item 2) [Figure 213].

Disconnect the cable from the excavator positive terminal (Item 1) [Figure 213].

Replace the positive battery cable cover.

Reinstall the right side panel and rear side cover.

Close the right side cover and tailgate.

NOTE: (See Cold Temperature Starting on Page 74.)

IMPORTANT

Damage to the alternator can occur if:

- Engine is operated with battery cables disconnected.
- Battery cables are connected when using a fast charger or when welding on the excavator. (Remove both cables from the battery.)
- Extra battery cables (booster cables) are connected wrong.

I-2223-0903

ELECTRICAL SYSTEM (CONT'D)

Removing And Installing The Battery

Open the tailgate. (See TAILGATE on Page 114.).

Open the right side cover. (See RIGHT SIDE COVER on Page 115.).

Remove the right side panel. (See RIGHT SIDE PANEL on Page 116.)

Remove the rear side cover (Item 2) [Figure 199].

Figure 214

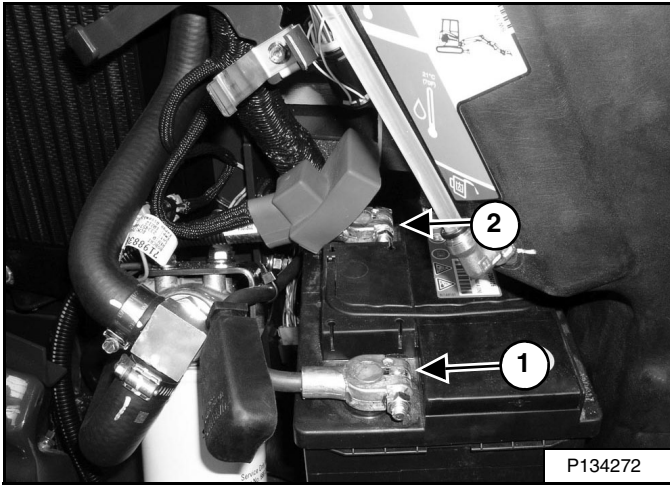

Disconnect the negative (-) cable (Item 1) [Figure 214] first.

Disconnect the positive (+) cable (Item 2) [Figure 214].

Figure 215

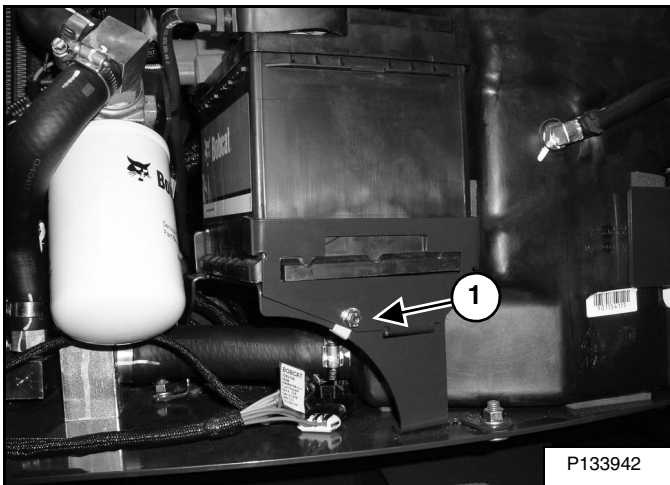

Remove the bolt (Item 1) [Figure 215] and remove the hold-down clamp.

Remove the battery.

Always clean the terminals and the cable ends, even when installing a new battery.

Install the battery. Install the hold-down clamp and tighten the bolts.

Connect the battery cables. Connect the negative (-) cable (Item 1) [Figure 214] last to prevent sparks.

Tighten the terminal clamp nuts to 7 N•m (5 ft-lb) torque.

Reinstall the right side panel and rear side cover.

Close the right side cover and tailgate.

WARNING

CHEMICAL HAZARD

Contact with or ingestion of battery acid can cause serious injury or death.

- Batteries contain acid that burns eyes and skin on contact. Wear safety goggles, protective clothing, and rubber gloves to keep acid off body.
- In case of acid contact, wash immediately with water. In case of eye contact, get prompt medical attention and wash eye with clean, cool water for at least 5 minutes.
- If electrolyte is ingested, drink large quantities of water or milk! DO NOT induce vomiting. Get prompt medical attention.

W-2065-0824

HYDRAULIC SYSTEM

Checking And Adding Hydraulic Oil

Put the machine on a flat level surface.

Retract the boom, arm, and bucket cylinders, put the bucket on the ground and lower the blade. Stop the engine.

Open the right side cover. (See RIGHT SIDE COVER on Page 115.)

Remove the right side panel. (See RIGHT SIDE PANEL on Page 116.)

Figure 216

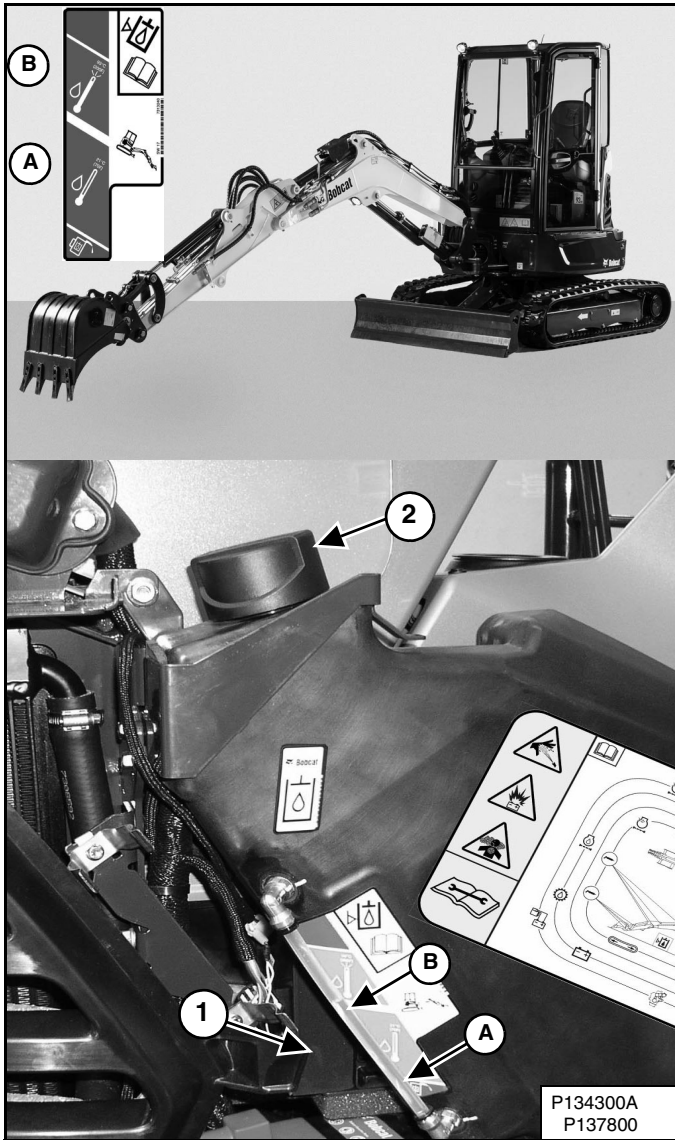

Park the machine in the position shown [Figure 216]. (The preferred method is to check the hydraulic oil when it is cold.)

Check the hydraulic oil level, it must be visible in the sight gauge (Item 1) [Figure 216]. The decal on the hydraulic tank shows the correct fill level.

- A - Correct Oil Level COLD (Preferred)
- B - Correct Oil Level HOT (Optional)

Clean the surface around the reservoir cap and remove the cap from the reservoir (Item 2) [Figure 216].

WARNING

FIRE AND EXPLOSION HAZARD

Failure to use care around combustibles can cause serious injury or death.

Always clean up spilled flammable fluids or oil. Keep heat, flames, sparks or lighted tobacco away from flammable fluids and oil.

W-2103-0824

Figure 217

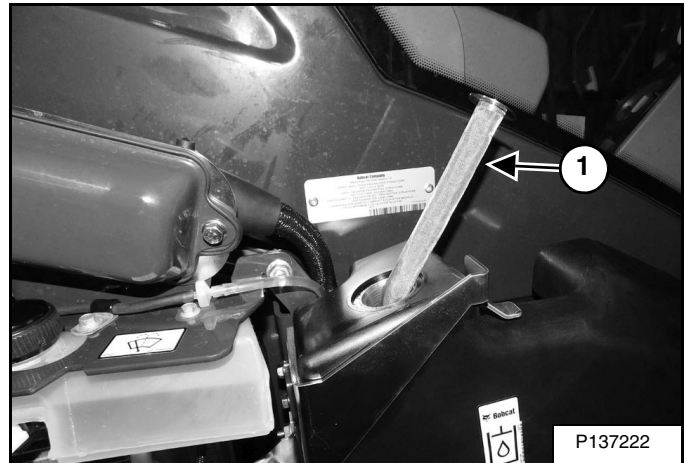

Check the condition of the fill strainer screen (Item 1) [Figure 217]. Clean or replace as necessary.

Be sure the screen is installed before adding fluid.

Add the correct fluid to the reservoir until it is visible in the sight gauge. (See Hydraulic / Hydrostatic Fluid Chart on Page 139.)

Check the cap and clean as necessary. Replace the cap if damaged.

Install the cap.

Reinstall the right side panel.

Close the right side cover.

HYDRAULIC SYSTEM (CONT'D)

Hydraulic / Hydrostatic Fluid Chart

Figure 218

HYDRAULIC / HYDROSTATIC FLUID RECOMMENDED ISO VISCOSITY GRADE (VG) AND VISCOSITY INDEX (VI)

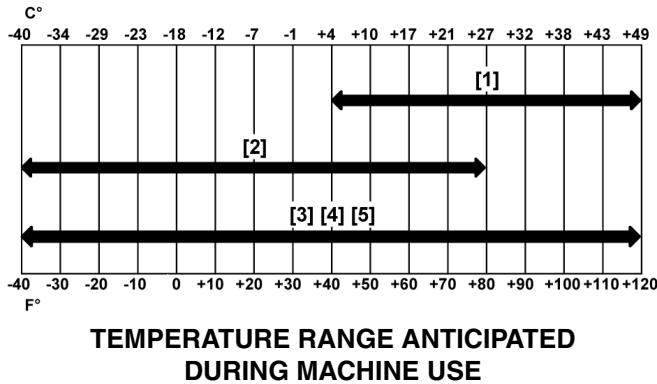

- [1] VG 100; Minimum VI 130
[2] VG 46; Minimum VI 150
[3] BOBCAT All-Season Fluid
[4] BOBCAT Synthetic Fluid
[5] BOBCAT Biodegradable Hydraulic / Hydrostatic Fluid (Unlike biodegradable fluids that are vegetable based, Bobcat biodegradable fluid is formulated to prevent oxidation and thermal breakdown at operating temperatures.)

WARNING

FIRE AND EXPLOSION HAZARD

Failure to use care around combustibles can cause serious injury or death.
Always clean up spilled flammable fluids or oil. Keep heat, flames, sparks or lighted tobacco away from flammable fluids and oil.

W-2103-0824

Removing And Replacing The Hydraulic Filters

Hydraulic Filter

See the SERVICE SCHEDULE for the correct service interval. (See SERVICE SCHEDULE on Page 108.)

Open the right side cover. (See RIGHT SIDE COVER on Page 115.)

Remove the right side panel. (See RIGHT SIDE PANEL on Page 116.)

Figure 219

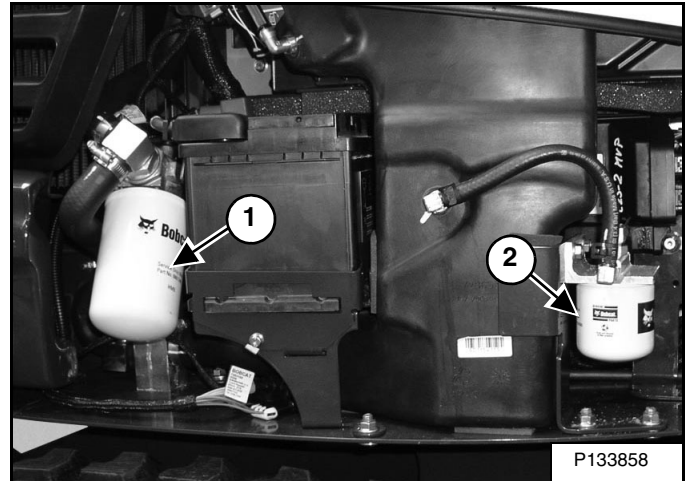

Remove the hydraulic filter (Item 1) [Figure 219].

Clean the housing where the filter gasket makes contact.

Put clean hydraulic fluid on the gasket. Install the new filter and hand tighten only. Use a genuine Bobcat replacement filter.

Case Drain Filter

See the service schedule for the correct service interval. (See SERVICE SCHEDULE on Page 108.)

Remove the case drain filter (Item 2) [Figure 219].

Clean the housing where the filter gasket makes contact.

Put clean hydraulic oil on the gasket. Install the new filter and hand tighten only.

Reinstall the right side panel.

Close the right side cover.

HYDRAULIC SYSTEM (CONT'D)

Removing And Replacing The Hydraulic Fluid

See the SERVICE SCHEDULE for the correct service interval. (See SERVICE SCHEDULE on Page 108.)

WARNING

INJECTION HAZARD

Pressurized diesel fuel or hydraulic fluid can penetrate skin and eyes, causing serious injury or death.

Fluid leaks under pressure may not be visible. Use a piece of cardboard or wood to find leaks. **DO NOT** use your bare hand. Wear safety goggles. If fluid enters skin or eyes, get immediate medical attention from a doctor familiar with this injury.

W-2072-0824

Figure 220

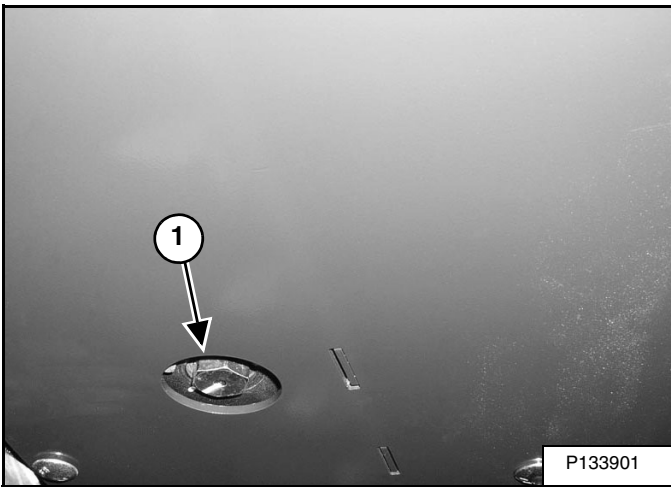

The hydraulic oil drain plug (Item 1) [Figure 220] is located beneath the right side of the upperstructure.

Rotate the upperstructure so that the hydraulic oil drain plug (Item 1) is located between the tracks.

Retract the arm and bucket cylinders, lower the bucket to the ground. Stop the engine.

Open the tailgate. (See TAILGATE on Page 114.)

Remove the plug (Item 1) [Figure 220].

Drain the fluid into a container.

Recycle or dispose of the fluid in an environmentally safe manner.

Install the plug (Item 1) [Figure 220].

Add fluid to the reservoir. (See Hydraulic / Hydrostatic Fluid Chart on Page 139.)

Figure 221

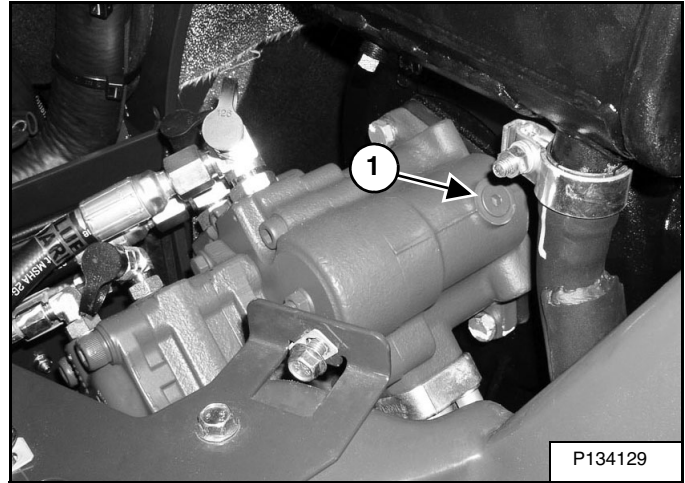

With the engine OFF, loosen the plug (Item 1) [Figure 221] on the hydraulic pump. Tighten the plug after a steady stream of hydraulic oil, free of any air bubbles, drains from the plug. **DO NOT RUN THE MACHINE WITH THE PLUG OPEN.**

Figure 222

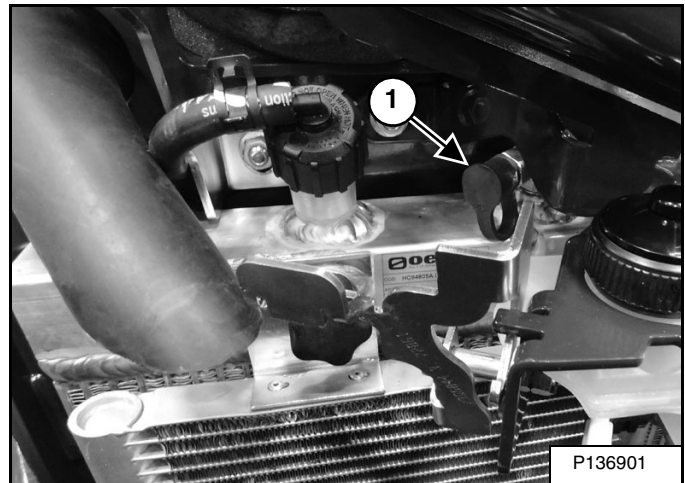

There is also a port (Item 1) on the hydraulic cooler for bleeding air. Install a diagnostic coupler and hose on this fitting to allow air to be bled from the hydraulic system after the hydraulic oil has been replaced.

Start the engine and operate the machine through the hydraulic functions. Stop the engine. Check the fluid level and add as needed.

SPARK ARRESTER MUFFLER

Cleaning Procedure

See the SERVICE SCHEDULE for the correct service interval. (See SERVICE SCHEDULE on Page 108.)

WARNING

AVOID INJURY OR DEATH

When an engine is running in an enclosed area, fresh air must be added to avoid concentration of exhaust fumes. If the engine is stationary, vent the exhaust outside. Exhaust fumes contain odorless, invisible gases which can kill without warning.

W-2050-0807

IMPORTANT

Engine or Exhaust System Damage

Failure to maintain the factory equipped U.S.D.A. Forestry Service Approved spark arrester exhaust system can result in improper function.

Consult the service schedule for the correct service interval. If this machine is operated on forest-covered land, brush-covered land, or grass-covered land, the engine must be equipped with a spark arrester and maintained in working order. Failure to do so will be in violation of California state law section 4442 PRC. Refer to local laws and regulations for spark arrester requirements.

I-2284-0325

WARNING

Never use machine in atmosphere with explosive dust or gases or where exhaust can contact flammable material. Failure to obey warnings can cause injury or death.

W-2068-1285

WARNING

Stop engine and allow the muffler to cool before cleaning the spark chamber. Wear safety goggles. Failure to obey can cause serious injury.

W-2011-1285

WARNING

When the engine is running during service, the steering levers must be in neutral.

Failure to do so can cause injury or death.

W-2203-0595

Do not operate the excavator with a defective exhaust system.

Stop the engine. Open the tailgate. (See TAILGATE on Page 114.)

Figure 223

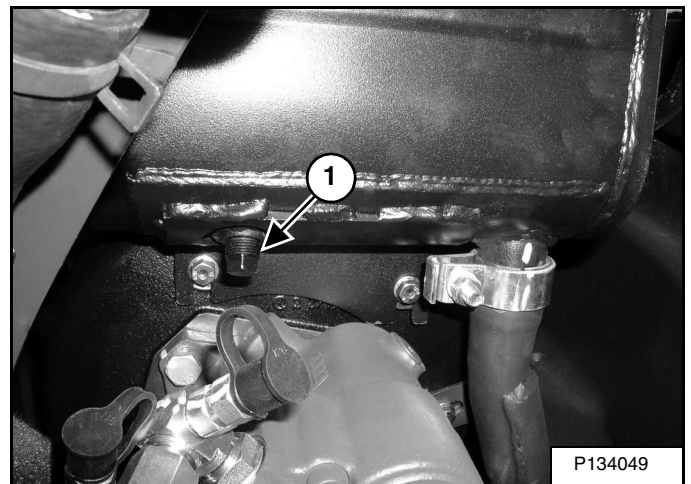

Remove the plug (Item 1) [Figure 223] from the bottom of the muffler.

Start the engine and run for about 10 seconds while a second person, wearing safety glasses, holds a piece of wood over the outlet of the muffler. The carbon deposits will be forced out of the muffler plug hole (Item 1) [Figure 223].

Stop the engine. Install and tighten the plug.

Close the tailgate.

TRACK TENSION

NOTE: The wear of the pins and bushings on the undercarriage vary with the working conditions and the different types of soil conditions. It is necessary to inspect track tension and maintain the correct tension. See **SERVICE SCHEDULE** for the correct service interval. (See **SERVICE SCHEDULE** on Page 108.)

Adjusting

Figure 224

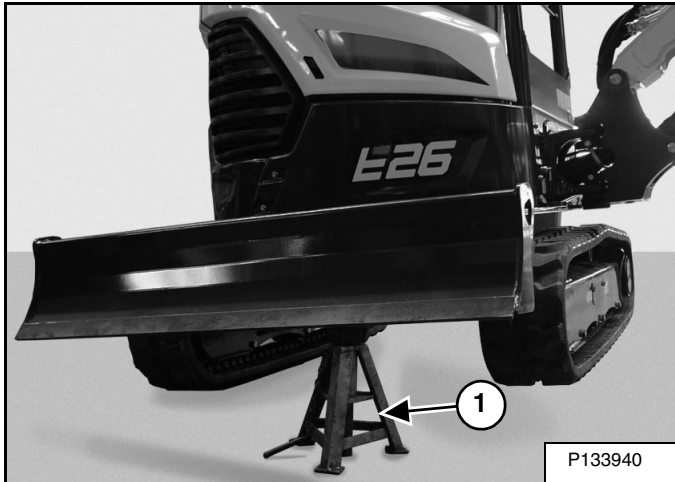
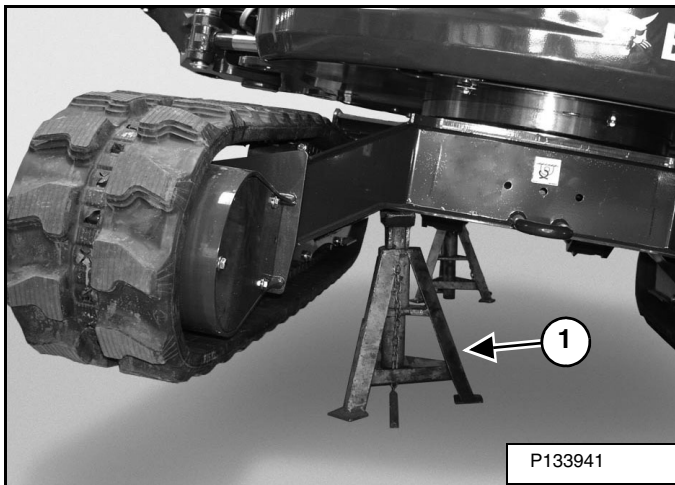

Figure 225



Raise the blade fully and install jackstands under the blade and track frame (Item 1) [Figure 224] and [Figure 225]. Raise the boom until all machine weight is on the jackstands.

Stop the engine.



WARNING

AVOID INJURY

Keep fingers and hands out of pinch points when checking the track tension.

W-2142-0903

Rubber Track Clearance

Figure 226

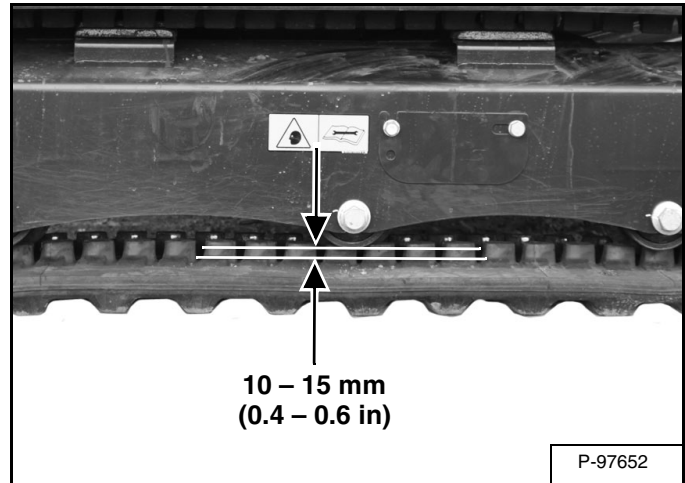
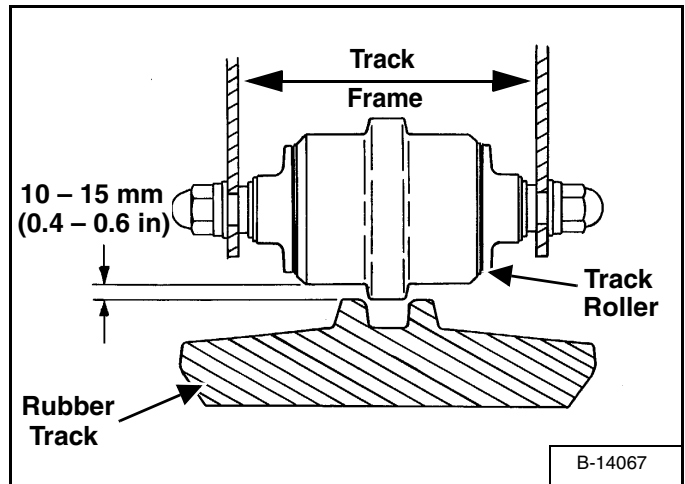

Figure 227



Measure the clearance at either middle track roller. Do not get fingers into pinch points between the track and the track roller. Use a bolt or a dowel of the appropriate size to check the gap between the contact edge of the roller and the top edge of the track guide [Figure 226] and [Figure 227].

Rubber Track Clearance	10 – 15 mm (0.4 – 0.6 in)
------------------------	------------------------------

TRACK TENSION (CONT'D)

Adjusting (Cont'd)

Figure 228

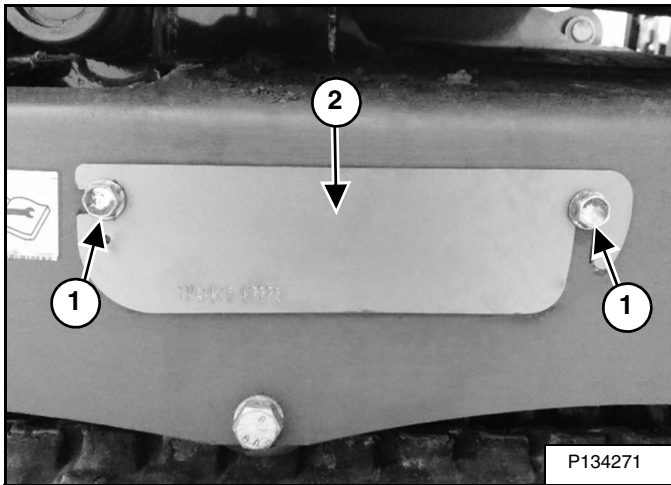

Loosen the access cover bolts (Item 1) and remove the access cover (Item 2) [Figure 229].

Figure 229

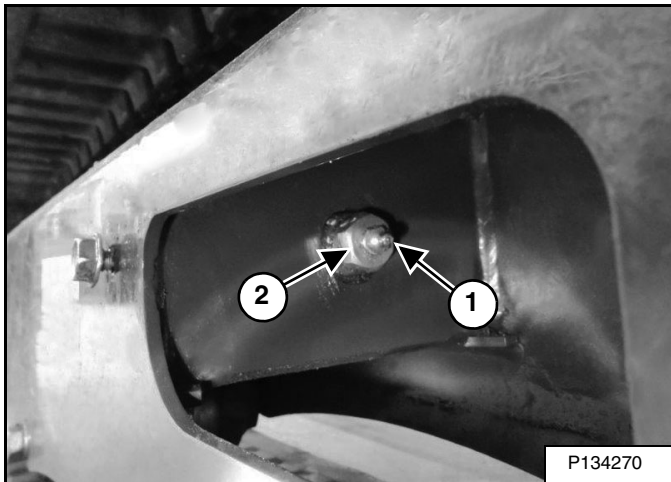

Increase Track Tension

Add grease to the fitting (Item 1) [Figure 229] until the track tension is correct.

Reinstall the access cover.

Decrease Track Tension



AVOID INJURY OR DEATH

If grease fitting is removed before pressure is released, the fitting can come off with great force and cause serious injury or death.

W-2490-0104

Pressure must be released from the grease cylinder to decrease track tension.

Loosen the bleed fitting (NOT the grease fitting) (Item 2) [Figure 229] and release pressure until the track tension is correct.

NOTE: DO NOT loosen the bleed fitting (Item 2) [Figure 229] for more than eight turns.

Tighten the bleed fitting to 80 – 100 N•m (59 – 74 ft-lb) torque.

Replace the access cover and tighten the access cover bolts.

Raise the machine and remove the jackstands.

Repeat the procedure for the other side.

Dispose of grease in an environmentally safe manner.

TRAVEL MOTOR

Checking And Adding Oil

Figure 230

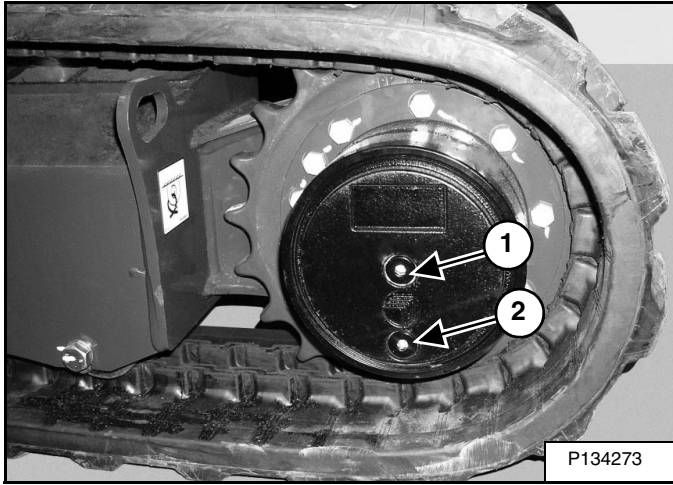

Park the excavator on a level surface with the plugs (Items 1 and 2) [Figure 230] in the vertical position as shown.

Remove the plug (Item 1) [Figure 230]. The lube level must be at the bottom edge of the hole.

Add lubricant (SAE 90W) through the hole if the lube level is low.

Removing And Replacing Oil

See the SERVICE SCHEDULE for the correct service interval. (See SERVICE SCHEDULE on Page 108.)

Park the excavator on a level surface with plugs (Items 1 and 2) [Figure 230] in the vertical position shown. Remove both plugs and drain the lubricant into a container.

WARNING

FIRE AND EXPLOSION HAZARD

Failure to use care around combustibles can cause serious injury or death.

Always clean up spilled flammable fluids or oil. Keep heat, flames, sparks or lighted tobacco away from flammable fluids and oil.

W-2103-0824

Install the bottom plug (Item 2) [Figure 230]. Add lubricant through the center plug hole until the lube level is at the bottom edge of the hole.

Add lubricant (SAE 80W-90 API GL-5) through the hole if the lube level is low.

Install the plug (Item 1) [Figure 230].

ALTERNATOR AND FAN BELT

Belt Adjustment

The alternator and fan belt is a special maintenance-free type that is pretensioned over the pulleys. This belt eliminates the need for a tensioning procedure and does not require periodic adjustment. Contact your Bobcat dealer for replacement parts.

Belt Replacement

Stop the engine and open the tailgate. (See Opening And Closing on Page 114.)

Figure 231

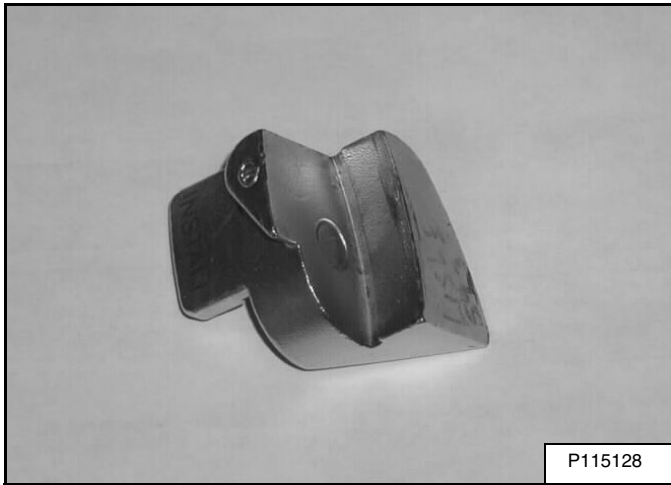

A belt tool [Figure 231] is required to install the new alternator and fan belt. See your Bobcat dealer.

Figure 232

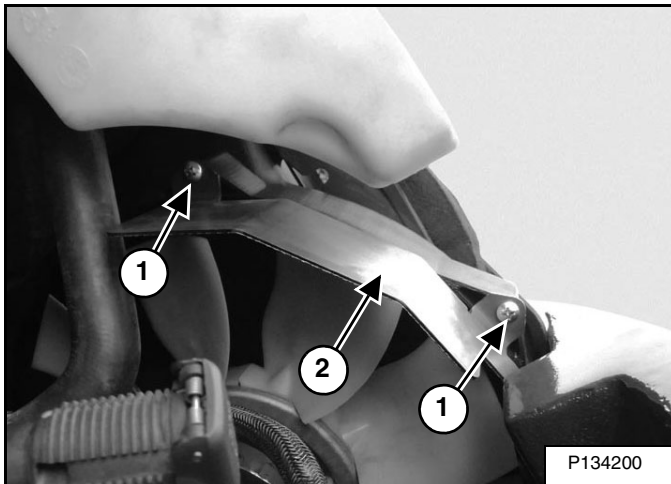

Remove belt shield mounting screws (Item 1) and remove the belt shield (Item 2) [Figure 232].

Figure 233

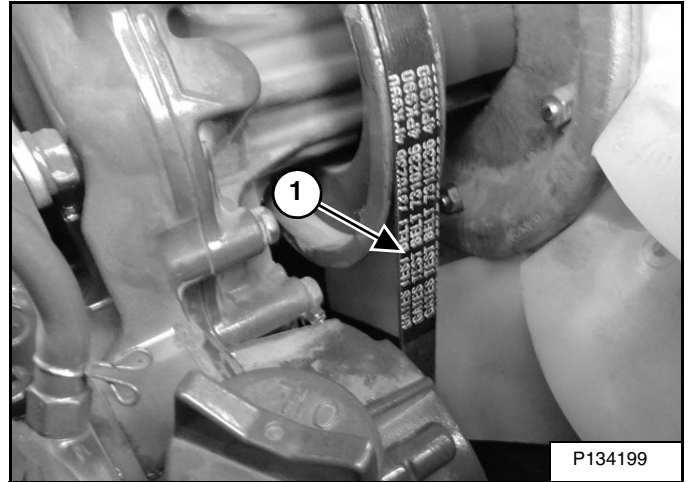

Cut the old belt (Item 1) [Figure 233] and remove the belt from the pulleys. Inspect the pulleys for wear.

Figure 234

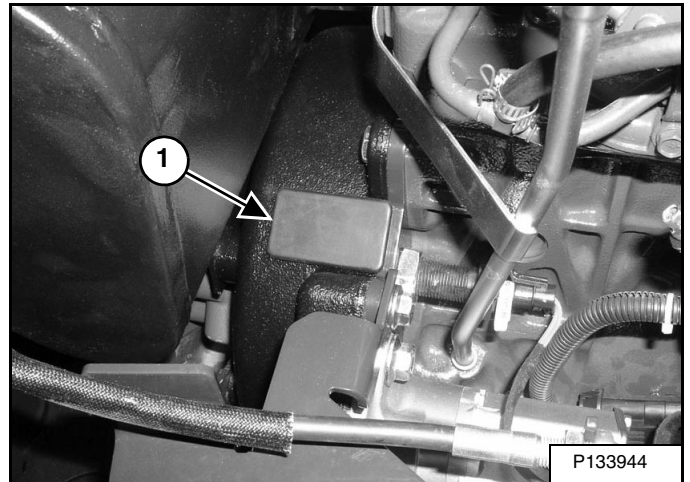

To access the flywheel, remove the plug (Item 1) [Figure 234] from the flywheel housing.

ALTERNATOR AND FAN BELT (CONT'D)

Belt Replacement (Cont'd)

Figure 235

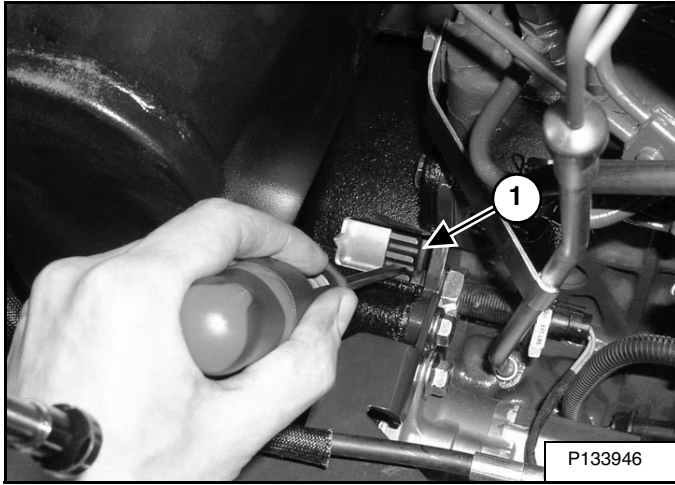

Install a pry bar in the flywheel teeth (Item 1) [Figure 235].

Figure 236

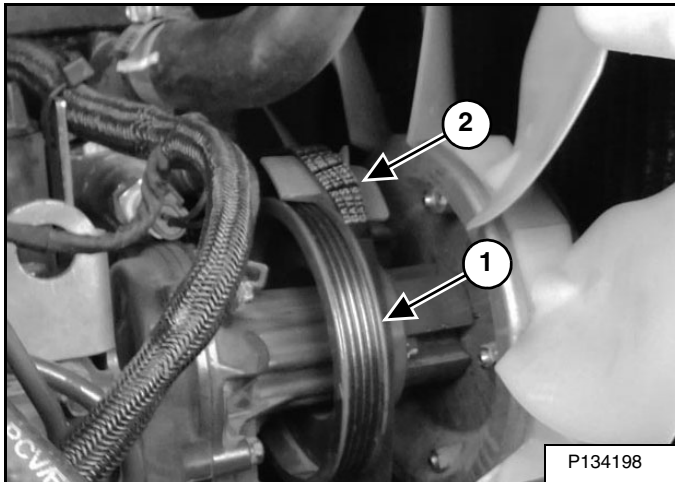

Install the belt on the crankshaft and alternator pulleys. Position the belt (Item 1) and belt tool (Item 2) [Figure 236] as shown here.

NOTE: Fan blades can be sharp, use care when installing the belt over the fan blades.

Use the pry bar to rotate the flywheel (Item 1) [Figure 235]. Continue to rotate until the belt is fully installed.

Remove the belt tool.

Install the flywheel plug (Item 1) [Figure 234].

Figure 237

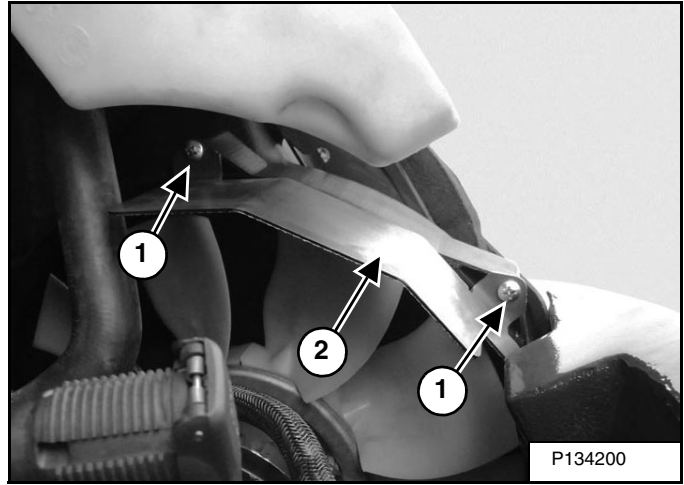

Install the belt shield (Item 2) with the two screws (Item 1) [Figure 237].

Close the tailgate.

X-CHANGE

Inspection And Maintenance

Figure 238

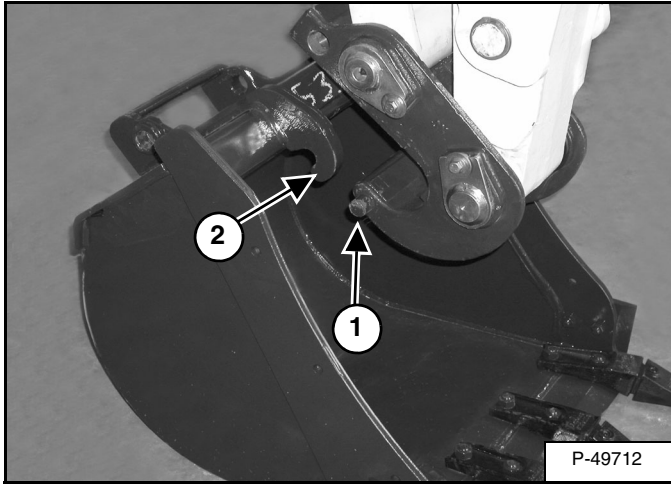

Inspect the X-Change for wear or damage. Inspect the X-Change pins (Item 1) and hooks (Item 2) [Figure 238] (on the attachment) for wear or damage.

Repair or replace damaged parts.

BUCKET

Bucket Teeth Removal And Installation

! WARNING

Wear safety glasses to prevent eye injury when any of the following conditions exist:

- Pressurized fluids and springs or other stored energy components.
- Flying debris or loose material is present.
- Engine is running.
- Tools are being used.

W-2505-0604

Position the bucket so the bucket teeth are at a 30° angle up from the ground for accessibility to the teeth.

Lower the boom until the bucket is fully on the ground.

Stop the engine and exit the excavator.

Figure 239

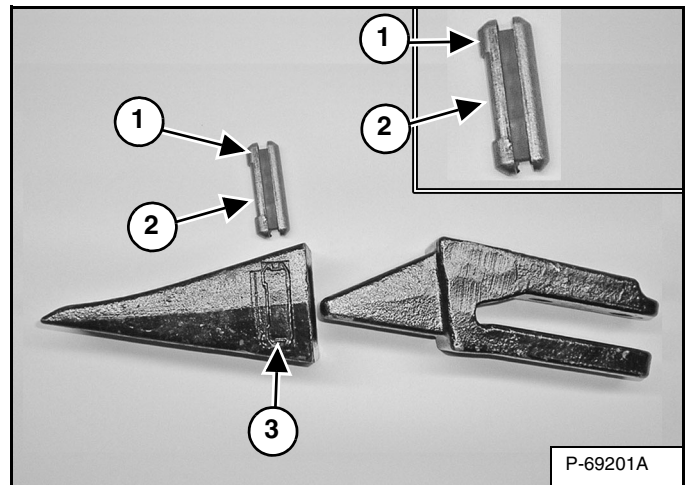

The retaining pin (Item 1) must be installed as shown (notch [Item 2] to the front) for proper fit and tooth retention. The side of the tooth point (Item 3) [Figure 239] also shows the correct orientation of the retaining pin.

Installation: Position the new tooth point on the shank and install a new retaining pin. Install the retaining pin until it is flush with the top of the point.

TRACK ROLLER AND IDLER LUBRICATION

Procedure

The track rollers and idlers require no maintenance. The bearings are a sealed design.

Lubrication Locations

Lubricate the excavator as specified in the service schedule for the best performance of the machine. (See SERVICE SCHEDULE on Page 108.)

Always use a good quality, lithium-based multipurpose grease when lubricating the machine. Apply the lubricant until extra grease shows.

Lubricate the following locations on the excavator **EVERY 8 – 10 HOURS**:

Figure 240

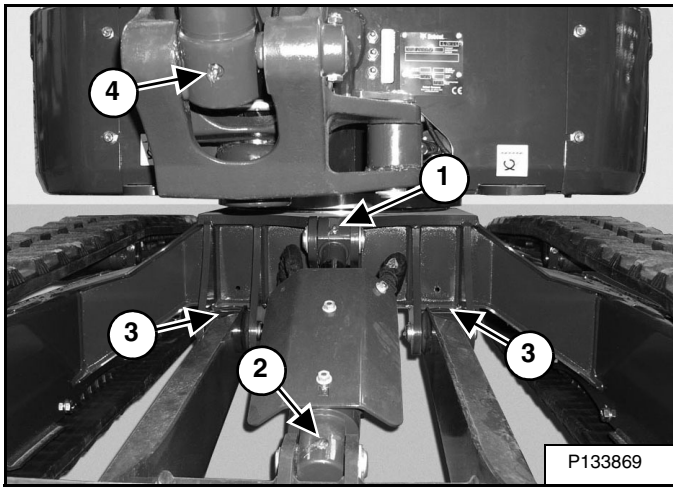

Ref Description (# of Fittings)

1. Blade Cylinder Rod End (1) [Figure 240].
2. Blade Cylinder Base End (1) [Figure 240].
3. Blade Pivots (2) [Figure 240].
4. Boom Cylinder Base End (1) [Figure 240].

Figure 241

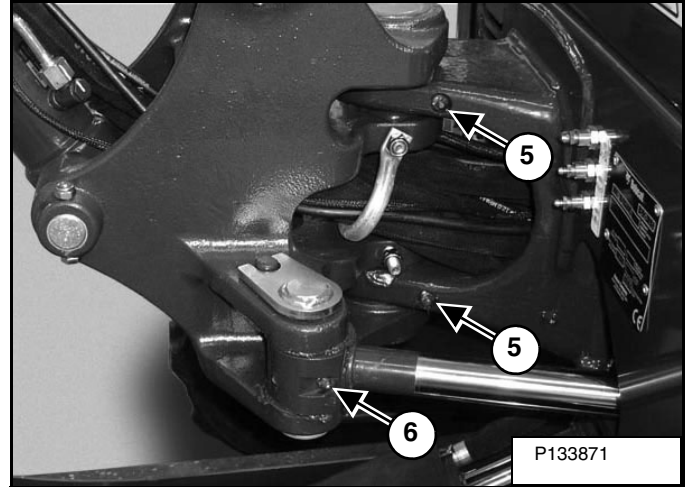

5. Boom Swing Pivot (3) [Figure 241].
6. Boom Swing Cylinder Rod End (1) [Figure 241].

Figure 242



7. Boom Pivot (1) [Figure 242].

LUBRICATING THE EXCAVATOR (CONT'D)

Lubrication Locations (Cont'd)

Figure 243

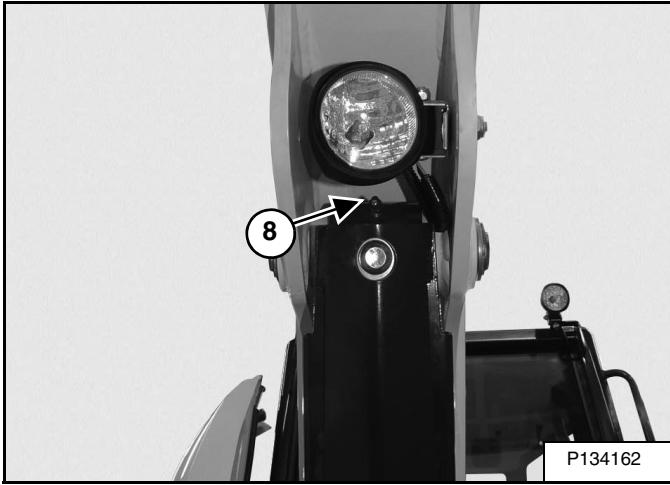

8. Boom Cylinder Rod End (1) [Figure 243].

Figure 244

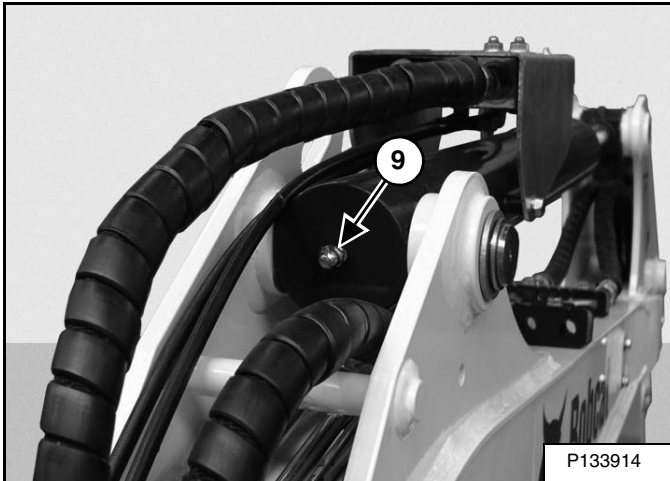

9. Arm Cylinder Base End (1) [Figure 244].

Figure 245

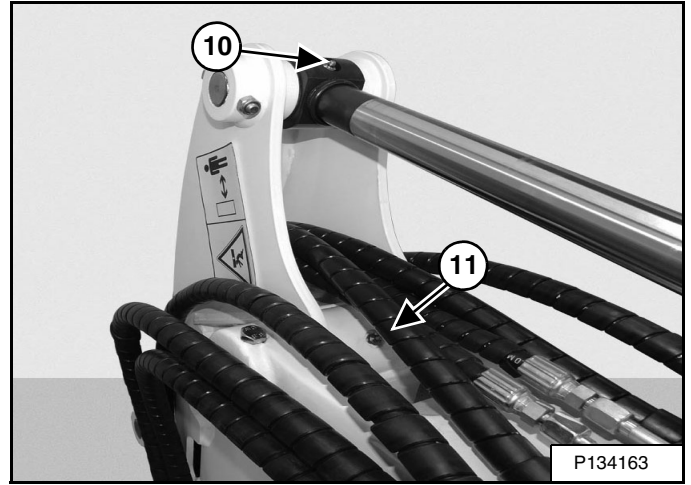

10. Arm Cylinder Rod End (1) [Figure 245].

11. Arm Pivot (1) [Figure 245].

Figure 246

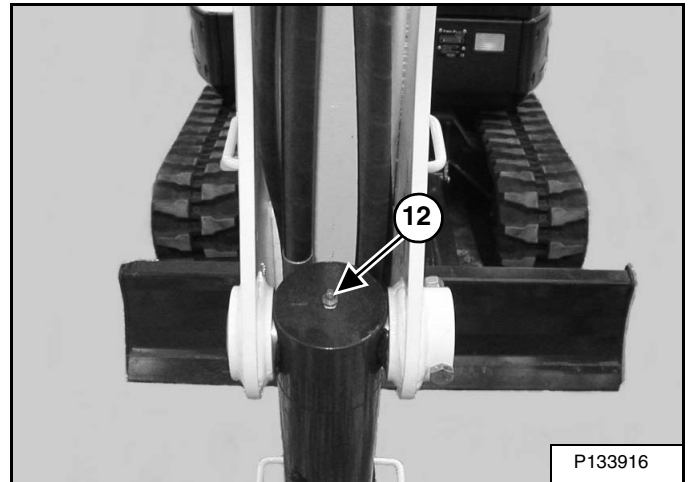

12. Bucket Cylinder Base End (1) [Figure 246].

LUBRICATING THE EXCAVATOR (CONT'D)

Lubrication Locations (Cont'd)

Figure 247

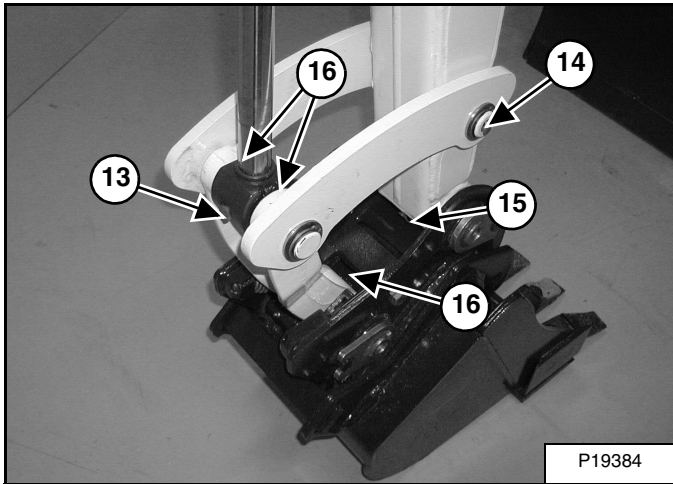

- 13. Bucket Cylinder Rod End (1) [Figure 247].
- 14. Bucket Link Pin (1) [Figure 247].
- 15. Bucket Pivot (1) [Figure 247].
- 16. Bucket Link (3) [Figure 247].

Figure 248

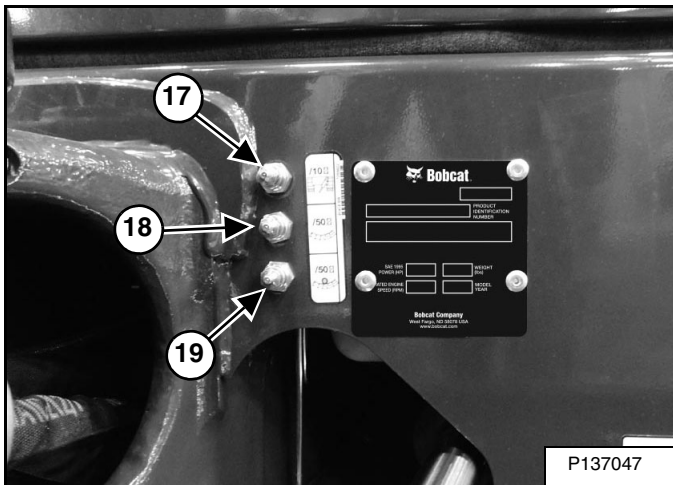

- 17. Boom Swing Cylinder Base (1) [Figure 248].

Lubricate the following locations on the hydraulic excavator **EVERY 50 HOURS**:

- 18. Slew Circle (1) [Figure 248].
- 19. Slew Pinion (1) [Figure 248]. (Install three to four pumps of grease then rotate the upperstructure 90°. Install three to four pumps of grease and again rotate the upperstructure 90°. Repeat this until the slew pinion has been greased at four positions.)

PIVOT PINS

Inspection And Maintenance

Figure 249

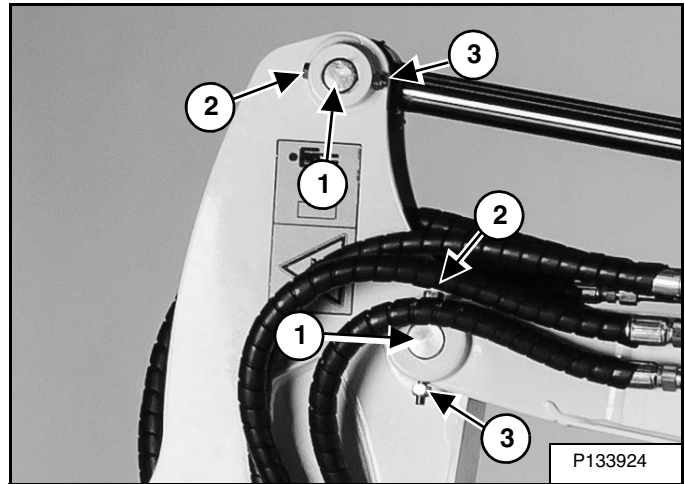

The pivots and cylinders (Item 1) have a large pin held in position with a bolt (Item 2) and a nut (Item 3) [Figure 249] securing the pin.

Installation: After the nut (Item 3) and bolt (Item 2) [Figure 249] are tightened together, the bolt should be free to spin.

EXCAVATOR STORAGE AND RETURN TO SERVICE

Storage

Sometimes it can be necessary to store your Bobcat excavator for an extended period of time. Below is a list of items to perform before storage:

- Thoroughly clean the excavator including the engine compartment.
- Lubricate the excavator.
- Replace worn or damaged parts.
- Drive the excavator onto planks in a dry protected shelter.
- Lower the boom fully with the bucket flat on the ground.
- Put grease on any exposed cylinder rods.
- Put fuel stabilizer in the fuel tank and run the engine a few minutes to circulate the stabilizer to the pump and fuel injectors.
- Drain and flush the cooling system. Refill with premixed coolant.
- Replace all fluids and filters (engine, hydraulic).
- Replace all filters (For example: air cleaner, heater, etc.).
- Put all controls in NEUTRAL position.
- Remove the battery. Be sure the electrolyte level is correct then charge the battery. Store it in a cool dry place above freezing temperatures and charge it periodically during storage.
- Cover the exhaust pipe opening.
- Tag the machine to indicate that it is in storage condition.

Return To Service

After the Bobcat excavator has been in storage, it is necessary to follow a list of items to return the excavator to service:

- Check the engine and hydraulic oil levels; check coolant level.
- Install a fully charged battery.
- Remove grease from exposed cylinder rods.
- Check all belt tensions.
- Be sure all shields and guards are in place.
- Lubricate the excavator.
- Remove cover from exhaust pipe opening.
- Start the engine and let run for a few minutes while observing the instrument panels and systems for correct operation.
- Drive the excavator off of the planks.
- Operate machine, check for correct function.
- Stop the engine and check for leaks. Repair as needed.

SYSTEM SETUP AND ANALYSIS

DIAGNOSTIC SERVICE CODES	153
Viewing Service Codes	153
Service Codes List	154
CONTROL PANEL SETUP	158
Panel Setup (Deluxe Instrument Panel)	158
PASSWORD SETUP (KEYLESS START PANEL)	164
Password Description	164
Changing The Owner, User 1, And User 2 Passwords	164
Password Lockout Feature	165
PASSWORD SETUP (DELUXE INSTRUMENT PANEL)	166
Password Description	166
Changing The Owner Password	166
Changing The User Passwords	167
Password Lockout Feature	167
MAINTENANCE CLOCK	168
Description	168
Standard Instrument Panel	168
Setup	168
Reset	168
Deluxe Instrument Panel	168

DIAGNOSTIC SERVICE CODES

Viewing Service Codes

The Service Codes will aid your dealer in diagnosing conditions that can damage your machine.

Standard Instrument Panel

Figure 250



Press the Information button (Item 2) to cycle the data display (Item 1) [Figure 250] until the service code screen is displayed. If more than one service code is present, the codes will scroll on the data display.

When no service code is present, [NONE] is displayed [Figure 250].

NOTE: Corroded or loose ground can cause multiple service codes and / or abnormal symptoms. All instrument panel lights flashing, alarm sounding, headlights and taillights flashing, can indicate a bad ground. The same symptoms can apply if the voltage is low, such as loose or corroded battery cables. If you observe these symptoms, check grounds and positive leads first.

Deluxe Instrument Panel

The last 40 codes stored in history can also be viewed using the Deluxe Instrument Panel.

<p>The image shows the Deluxe Instrument Panel with the 'ACTIVE WARNINGS' screen. A warning icon (exclamation mark in a triangle) is highlighted in the top left corner. A scroll button (arrow) is highlighted with a '1' in a circle. The screen displays '13000' and '15'. The 'ENTER' button is also visible.</p>	<p>Press a scroll button (Item 1) repeatedly until the Active Warnings screen icon (Inset) is highlighted.</p>																																				
<p>The image shows the 'ACTIVE WARNINGS' screen displaying 'R7404 MAIN CONTROLLER NO COMMUNICATION'. A scroll button is highlighted with a '9' in a circle. The 'ENTER' button is visible at the bottom.</p>	<p>The ACTIVE WARNINGS screen displays active service codes. Press [9] to view the next service code if more than one is present. Press [4] to display a history of service codes.</p>																																				
<p>The image shows the 'WARNINGS HISTORY' screen with a table of codes:</p> <table border="1"> <thead> <tr> <th>CODE</th> <th>HOUR</th> <th>USER</th> <th>1 of 3</th> </tr> </thead> <tbody> <tr> <td>1. M4404</td> <td>ACTIVE</td> <td>BRADY</td> <td></td> </tr> <tr> <td>2. M9259</td> <td>ACTIVE</td> <td>BRADY</td> <td></td> </tr> <tr> <td>3. M7497</td> <td>1339</td> <td>OWNER</td> <td></td> </tr> <tr> <td>4. D7557</td> <td>1339</td> <td>?</td> <td></td> </tr> <tr> <td>5. M0415</td> <td>1339</td> <td>JOHN</td> <td></td> </tr> <tr> <td>6. M0414</td> <td>1339</td> <td>JOHN</td> <td></td> </tr> <tr> <td>7. M3128</td> <td>1338</td> <td>SCOTT</td> <td></td> </tr> <tr> <td>8. M4404</td> <td>1338</td> <td>SCOTT</td> <td></td> </tr> </tbody> </table> <p>The 'ENTER' button is visible at the bottom.</p>	CODE	HOUR	USER	1 of 3	1. M4404	ACTIVE	BRADY		2. M9259	ACTIVE	BRADY		3. M7497	1339	OWNER		4. D7557	1339	?		5. M0415	1339	JOHN		6. M0414	1339	JOHN		7. M3128	1338	SCOTT		8. M4404	1338	SCOTT		<p>The WARNINGS HISTORY screen will list the Service Code Number (CODE), Hourmeter reading when the error occurred (HOUR), and the User (USER) who was logged in to operate the machine when the error occurred.</p>
CODE	HOUR	USER	1 of 3																																		
1. M4404	ACTIVE	BRADY																																			
2. M9259	ACTIVE	BRADY																																			
3. M7497	1339	OWNER																																			
4. D7557	1339	?																																			
5. M0415	1339	JOHN																																			
6. M0414	1339	JOHN																																			
7. M3128	1338	SCOTT																																			
8. M4404	1338	SCOTT																																			
<p>Press [9] to view the next eight service codes.</p> <p>A total of 40 codes can be stored. When more than 40 codes occur, the oldest code will disappear and the newest code will be in the number 1 position.</p>																																					
<p>The image shows the 'WARNINGS HISTORY' screen with 'R7404 MAIN CONTROLLER NO COMMUNICATION' selected. The 'Hour' is 296 and the 'User' is Brady. A scroll button is highlighted with a '1' in a circle. The 'ENTER' button is visible at the bottom.</p>	<p>Press the list number next to the service code for more detail.</p> <p>Press the left scroll button to back up one screen.</p>																																				

DIAGNOSTIC SERVICE CODES (CONT'D)

Service Codes List

CODE	DESCRIPTION
H0104	Boom Angle Sensor No Communication
H0204	Arm Angle Sensor No Communication
H0304	Bucket Angle Sensor No Communication
H0405	Angle Sensor Supply Short To Battery
H0406	Angle Sensor Supply Short To Ground
H0407	Angle Sensor Supply Open Circuit
H0705	Aux 4 Base Short to Battery
H0706	Aux 4 Base Short to Ground
H0707	Aux 4 Base Open Circuit
H0732	Aux 4 Base Overcurrent
H0805	Aux 4 Rod Short to Battery
H0806	Aux 4 Rod Short to Ground
H0807	Aux 4 Rod Open Circuit
H0832	Aux 4 Rod Overcurrent
H2521	Angle Blade Control Switch Out Of Range High
H2522	Angle Blade Control Switch Out Of Range Low
H2524	Angle Blade Control Switch Out Of Neutral
H2605	Angle Blade Base Solenoid Short To Battery
H2606	Angle Blade Base Solenoid Short To Ground
H2607	Angle Blade Base Solenoid Open Circuit
H2632	Angle Blade Base Solenoid Overcurrent
H2705	Angle Blade Rod Solenoid Short To Battery
H2706	Angle Blade Rod Solenoid Short To Ground
H2707	Angle Blade Rod Solenoid Open Circuit
H2732	Angle Blade Rod Solenoid Overcurrent
H2805	Diverter Output Short To Battery
H2806	Diverter Output Short To Ground
H2807	Diverter Output Open Circuit
H2832	Diverter Output Overcurrent
H2848	Diverter Multiple Input
H3128	Interrupted Power Failure
H3904	Left Joystick In Error
H3912	Left Joystick Thumb Switch Not In Neutral

CODE	DESCRIPTION
H3913	Left Joystick Grip No Communication
H3916	Left Joystick No Communication
H3928	Left Joystick Internal Failure
H3948	Left Joystick Multiple
H4423	Secondary Not Programmed
H4497	Secondary Controller Programmed
H4621	5 Volt Sensor Supply Out Of Range High
H4622	5 Volt Sensor Supply Out Of Range Low
H4721	8 Volt Sensor Supply Out Of Range High
H4722	8 Volt Sensor Supply Out Of Range Low
H5705	Angle Blade Aux 4 Base Short to Battery
H5706	Angle Blade Aux 4 Base Short to Ground
H5707	Angle Blade Aux 4 Base Open Circuit
H5732	Angle Blade Aux 4 Base Overcurrent
H5805	Angle Blade Aux 4 Rod Short to Battery
H5806	Angle Blade Aux 4 Rod Short to Ground
H5807	Angle Blade Aux 4 Rod Open Circuit
H5832	Angle Blade Aux 4 Rod Overcurrent
H7404	Main Controller No Communication
H7604	Display No Communication
H7902	Door Unlock Error On
H7903	Door Unlock Error Off
H8002	Door Lock Error On
H8003	Door Lock Error Off
L0102	Lights Button Error On
L0202	High Flow Enable Button Error On
L0302	Auxiliary Enable Button Error On
L0402	Information Button Error On
L7404	Information Button Error On
L7672	Information Button Error On
LOWVLTG	Machine IQ Device Low Voltage
M0116	Air Filter Not Connected
M0117	Air Filter Plugged
M0144	Air Filter Derate Level 1
M0145	Air Filter Derate Level 2
M0216	Hydraulic/hydrostatic Filter Not Connected
M0217	Hydraulic/hydrostatic Filter Plugged
M0309	System Voltage Too Low
M0310	System Voltage Too High
M0311	System Voltage Extremely High

CODE	DESCRIPTION
M0314	System Voltage Extremely Low
M0322	System Voltage Out Of Range Low
M0414	Engine Oil Pressure Extremely Low
M0415	Engine Oil Pressure In Shutdown
M0610	Engine Speed Too High
M0611	Engine Speed Extremely High
M0613	Engine Speed No Signal
M0615	Engine Speed In Shutdown
M0618	Engine Speed Out Of Range
M0710	Hydraulic Oil Temp Too High
M0711	Hydraulic Oil Temp Extremely High
M0715	Hydraulic Oil Temp In Shutdown
M0721	Hydraulic Oil Temp Out Of Range High
M0722	Hydraulic Oil Temp Out Of Range Low
M0810	Engine Coolant Temp Too High
M0811	Engine Coolant Temp Extremely High
M0815	Engine Coolant Temp In Shutdown
M0821	Engine Coolant Temp Out Of Range High
M0822	Engine Coolant Temp Out Of Range Low
M0826	Engine Coolant Temp Out Of Range Low
M0909	Fuel Level Too Low
M0921	Fuel Level Out Of Range High
M0922	Fuel Level Out Of Range Low
M1121	Console Sensor Out Of Range High
M1122	Console Sensor Out Of Range Low
M1128	Console Sensor Failure
M1305	Fuel Hold Solenoid Short To Battery
M1306	Fuel Hold Solenoid Short To Ground
M1307	Fuel Hold Solenoid Open Circuit
M1402	Fuel Pull Solenoid Error On
M1403	Fuel Pull Solenoid Error Off
M1407	Fuel Pull Solenoid Open Circuit
M1428	Fuel Pull Solenoid Failure
M1605	Hydraulic Bypass Short to Battery
M1606	Hydraulic Bypass Short to Ground
M1607	Hydraulic Bypass Open Circuit
M1632	Hydraulic Bypass Overcurrent
M1705	Hydraulic Lock Valve Short To Battery
M1706	Hydraulic Lock Valve Short To Ground
M1707	Hydraulic Lock Valve Open Circuit
M1732	Hydraulic Lock Valve Overcurrent
M1802	Power Beyond Valve Output Error On

CODE	DESCRIPTION
M1803	Power Beyond Valve Output Error Off
M1902	Power Beyond Valve Relay Error On
M1903	Power Beyond Valve Relay Error Off
M2005	Two Speed Primary Solenoid Short To Battery
M2006	Two Speed Primary Solenoid Short To Ground
M2007	Two Speed Primary Solenoid Open Circuit
M2102	Glow Plug Output Error On
M2103	Glow Plug Output Error Off
M2107	Glow Plug Output Open Circuit
M2128	Glow Plug Output Failure
M2202	Starter Output Error On
M2203	Starter Output Error Off
M2207	Starter Output Open Circuit
M2228	Starter Output Failure
M2302	Starter Relay Error On
M2303	Starter Relay Error Off
M2402	Fuel Pull Relay Error On
M2403	Fuel Pull Relay Error Off
M2521	Load Sense Sensor Out Of Range High
M2522	Load Sense Sensor Out Of Range Low
M2602	Glow Plug Relay Error On
M2603	Glow Plug Relay Error Off
M2721	Throttle Primary Sensor Out Of Range High
M2722	Throttle Primary Sensor Out Of Range Low
M2805	Diverter Output Short To Battery
M2806	Diverter Output Short To Ground
M2807	Diverter Output Open Circuit
M3128	Interrupted Power Failure
M3204	Throttle Controller No Communication To Bobcat Controller
M3223	Throttle Controller Not Calibrated
M3228	Throttle Controller Failure
M3299	Throttle Controller Calibration In Process
M3304	Deluxe Panel No Communication
M3372	Display Software Incompatible
M3373	Display Software Outdated
M3702	HYD Exchange Output Error On
M3703	HYD Exchange Output Error Off
M3904	Jog Shuttle No Communication

CODE	DESCRIPTION
M4028	Wrong ECU Detected
M4109	Alternator Voltage Too Low
M4110	Alternator Voltage High
M4204	Keyless Entry No Communication
M4304	Keyless Start Panel No Communication
M4404	Secondary No Communication
M4472	Secondary Controller Software Incompatible
M4473	Secondary Controller Software Outdated
M4621	5 Volt Sensor Supply Out Of Range High
M4622	5 Volt Sensor Supply Out Of Range Low
M4721	8 Volt Sensor Supply Out Of Range High
M4722	8 Volt Sensor Supply Out Of Range Low
M4802	Front Light Relay Error On
M4803	Front Light Relay Error Off
M5002	Front Light Output Error On
M5003	Front Light Output Error Off
M5205	Offset Base Solenoid Short To Battery
M5206	Offset Base Solenoid Short To Ground
M5207	Offset Base Solenoid Open Circuit
M5232	Offset Base Solenoid Overcurrent
M5305	Offset Rod Solenoid Error On
M5306	Offset Rod Solenoid Short To Ground
M5307	Offset Rod Solenoid Open Circuit
M5332	Offset Rod Solenoid Overcurrent
M5421	Offset Control Switch Out Of Range High
M5422	Offset Control Switch Out Of Range Low
M5424	Offset Control Switch Out Of Neutral
M5505	Auxiliary Base Solenoid Short To Battery
M5506	Auxiliary Base Solenoid Short To Ground
M5507	Auxiliary Base Solenoid Open Circuit
M5532	Auxiliary Base Solenoid Overcurrent
M5605	Auxiliary Rod Solenoid Short To Battery
M5606	Auxiliary Rod Solenoid Short To Ground
M5607	Auxiliary Rod Solenoid Open Circuit
M5632	Auxiliary Rod Solenoid Overcurrent
M5721	Auxiliary Control Switch Out Of Range High
M5722	Auxiliary Control Switch Out Of Range Low
M5724	Auxiliary Control Switch Out Of Neutral
M5810	Fuel Temperature High
M5811	Fuel Temperature Extremely High

CODE	DESCRIPTION
M5815	Fuel Temperature In Shutdown
M5826	Fuel Temperature In Shutdown
M6021	Left Control Switch Out of Range High
M6022	Left Control Switch Out of Range Low
M6024	Left Control Switch Out of Neutral
M6121	Right Control Switch Out of Range High
M6122	Right Control Switch Out of Range Low
M6124	Right Control Switch Out of Neutral
M6204	Load Moment Sensor In Error
M6221	Overload Warning Sensor Out of Range High
M6222	Overload Warning Sensor Out of Range Low
M6402	Switched Power Relay Error On
M6403	Switched Power Relay Error Off
M6505	ECU Power Short To Battery
M6506	ECU Power Short To Ground
M6507	ECU Power Open Circuit
M6604	ECU No Communication
M6702	HVAC Output Error On
M6703	HVAC Output Error Off
M6905	Dump Valve Short to Battery
M6906	Dump Valve Short to Ground
M6907	Dump Valve Open Circuit
M6932	Dump Valve Overcurrent
M7002	Switched Power Output Error On
M7003	Switched Power Output Error Off
M7007	Switched Power Output Open Circuit
M7028	Switched Power Output Failure
M7423	Main Controller Not Programmed
M7472	Main Controller Software Incompatible
M7473	Main Controller Software Outdated
M7497	Main Controller Programmed
M7604	Standard Display Panel No Communication
M7748	Key Switch Multiple
M7839	Hourmeter Changed
M8004	Cooling Fan Controller No Communication
M8005	Cooling Fan Short To Battery
M8006	Cooling Fan Short To Ground
M8021	Cooling Fan Out Of Range High
M8022	Cooling Fan Out Of Range Low

CODE	DESCRIPTION
M8025	Cooling Fan Unresponsive
M8027	Cooling Fan CAN Error
M8028	Cooling Fan Failure
M8029	Cooling Fan Wiring Fault
M8030	Cooling Fan Controller Fault
M8302	Wait to Start Lamp Error On
M8303	Wait to Start Lamp Error Off
M8615	Engine Speed Derate In Shutdown
M8625	Engine Speed Derate Unresponsive
M9111	Fuel Filter Extremely Plugged
M9117	Fuel Filter Plugged
M9144	Fuel Filter Derate Level 1
M9145	Fuel Filter Derate Level 2
M9202	Fuel Lift Pump Error On
M9203	Fuel Lift Pump Error Off
M9287	Fuel Pump Failure Time Exceeded
M9309	Fuel Pressure Low
M9314	Fuel Pressure Extremely Low
M9321	Fuel Pressure Out Of Range High
M9322	Fuel Pressure Out Of Range Low
M9344	Fuel Pressure Derate Level 1
M9701	Turbo Prime Sequence Active
R3327	Display CAN Error
R3334	Display CAN Error
R3335	Display CAN Error
R3904	Jog Shuttle No Communication
R7404	Main Controller No Communication
R7492	Main Controller Authentication Failed
R9604	Radio No Communication
VRLOWVLTG	Machine IQ Device Very Low Voltage

CONTROL PANEL SETUP

Panel Setup (Deluxe Instrument Panel)

Icon Identification

Figure 251



ICON	DESCRIPTION
Mon, 17 Mar 3:45 PM	DATE / TIME
MINNY 234.5	USER / USER HOURS
Machine 353.5	MACHINE HOURS (HOURMETER)
	ACTIVE WARNINGS screen icon
	VITALS screen icon
	SERVICE screen icon
	AUTO IDLE Status icon
	ATTACHMENTS screen icon
	MACHINE SETTINGS screen icon
	DISPLAY screen icon
	HOME icon (Return to MAIN screen)
	LEFT SCROLL button
	RIGHT SCROLL button
ENTER	ENTER button

Vitals







	Press a scroll button (Item 1) repeatedly until the Vitals screen icon (Inset) is highlighted.
	Displays select system operating levels.
<p>You can monitor real-time displays of:</p> <ul style="list-style-type: none"> Engine Speed (RPM) Engine Coolant Temperature System Voltage Hydraulic Fluid Temperature 	

The Deluxe Instrument Panel is easy to use. Continue to set your own preferences for operating / monitoring your Bobcat excavator.



CONTROL PANEL SETUP (CONT'D)

Panel Setup (Deluxe Instrument Panel) (Cont'd)



Date And Time

	<p>Press a scroll button (Item 1) repeatedly until the Display screen icon (Inset) is highlighted.</p>
	<p>Select [1. CLOCKS].</p>
	<p>Select [1. TIME].</p>
	<p>Use the keypad to enter time.</p> <p>Select AM / PM / 24hr.</p> <p>Press [ENTER] to continue.</p>
	<p>Select [2. DATE].</p>
	<p>Use the keypad to enter date.</p> <p>Press [ENTER] to continue.</p>

Languages

	<p>Press a scroll button (Item 1) repeatedly until the Display screen icon (Inset) is highlighted.</p>
	<p>Select [2. LANGUAGES].</p>
	<p>Select the desired language.</p>





English / Metric Display

	<p>Press a scroll button (Item 1) repeatedly until the Display screen icon (Inset) is highlighted.</p>
	<p>Select [4. DISPLAY SETTINGS].</p> <p>Press [1] to cycle between ENGLISH and METRIC.</p>







CONTROL PANEL SETUP (CONT'D)

Panel Setup (Deluxe Instrument Panel) (Cont'd)

Auto Idle Time Delay

	<p>Press a scroll button (Item 1) repeatedly until the Security screen icon (Inset) is highlighted.</p>
	<p>Select [3. MACHINE PERFORMANCE].</p>
	<p>Select [1. AUTO IDLE DELAY TIME].</p>
	<p>Use the keypad to enter the desired delay time between 4 and 250 seconds.</p> <p>Press [ENTER] to save and continue. Press left scroll button to exit without saving.</p>







Job Clock Reset

	<p>Press a scroll button (Item 1) repeatedly until the Security screen icon (Inset) is highlighted.</p>
	<p>Select [1. PASSWORDS / LOCKOUTS].</p>
	<p>Enter owner password and press [ENTER].</p>
	<p>Select [1. USER SETTINGS].</p>
	<p>Select user.</p>
	<p>Press [9] to reset job statistics.</p> <p>Press left scroll button or [0] to exit without saving.</p>



CONTROL PANEL SETUP (CONT'D)

Panel Setup (Deluxe Instrument Panel) (Cont'd)

Alarm Clock Reset

	<p>Press a scroll button (Item 1) repeatedly until the Display screen icon (Inset) is highlighted.</p>
	<p>Select [3. ALARM CLOCK].</p>
	<p>Select [1. OFF ONCE], Select [2. ON Daily] or Select [3. ON WEEKLY].</p>
	<p>Select [1. OFF / ON], Select [2. TIME] or Select [3. DAILY].</p>
	<p>Use keypad numbers to set time. Select [7. AM], Select [8. PM] or Select [9. 24 hr clock].</p> <p>Select [ENTER] to save. Press left scroll to back space numbers.</p>
	<p>Press [4] to set alarm to sleep. (When pressed, display will return to main screen.)</p> <p>Press [9] to shut off alarm. Alarm will still be active for the next day alarm setting. (When pressed, display will return to main screen.)</p>

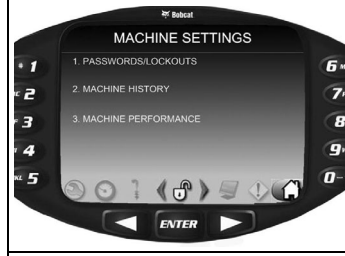



ECO MODE

	<p>Press a scroll button (Item 1) repeatedly until the Security screen icon (Inset) is highlighted.</p>
	<p>Select [3. MACHINE PERFORMANCE].</p>
	<p>Select [2. ECO MODE].</p> <p>ECO Mode will set the maximum engine rpm to be at 85% of the high idle setting.</p> <p>Example: If the machine maximum engine speed is 2450 rpm, when ECO Mode is enabled, the maximum engine speed will be approximately 2080 rpm.</p>

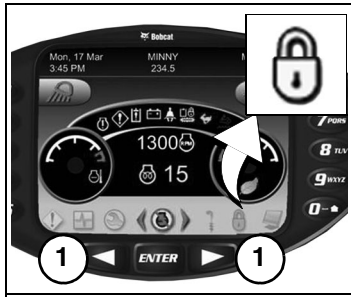

CONTROL PANEL SETUP (CONT'D)

Panel Setup (Deluxe Instrument Panel) (Cont'd)

Machine History - Log In Information

	<p>Press a scroll button (Item 1) repeatedly until the Security screen icon (Inset) is highlighted.</p>																		
	<p>MACHINE SETTINGS is visible on screen.</p> <p>Select [2. MACHINE HISTORY].</p>																		
	<p>Select [1. LOG-IN INFORMATION].</p>																		
 <table border="1" data-bbox="129 1176 373 1270"> <thead> <tr> <th>USER</th> <th>HOUR</th> <th>TIME</th> </tr> </thead> <tbody> <tr> <td>1. MIKE</td> <td>1072</td> <td>7:45 AM 06/22/2011</td> </tr> <tr> <td>2. BRADY</td> <td>1065</td> <td>8:10 AM 06/21/2011</td> </tr> <tr> <td>3. SCOTT</td> <td>1055</td> <td>6:23 AM 06/19/2011</td> </tr> <tr> <td>4. SHANNON</td> <td>1053</td> <td>3:11 PM 06/18/2011</td> </tr> <tr> <td>5. SCOTT</td> <td>1048</td> <td>6:53 AM 06/18/2011</td> </tr> </tbody> </table>	USER	HOUR	TIME	1. MIKE	1072	7:45 AM 06/22/2011	2. BRADY	1065	8:10 AM 06/21/2011	3. SCOTT	1055	6:23 AM 06/19/2011	4. SHANNON	1053	3:11 PM 06/18/2011	5. SCOTT	1048	6:53 AM 06/18/2011	<p>View User Log hours and last time / dated used.</p> <p>Individual information can be viewed and reset back to zero.</p> <p>Select user [KEYPAD 1 - 9] to access individual user.</p>
USER	HOUR	TIME																	
1. MIKE	1072	7:45 AM 06/22/2011																	
2. BRADY	1065	8:10 AM 06/21/2011																	
3. SCOTT	1055	6:23 AM 06/19/2011																	
4. SHANNON	1053	3:11 PM 06/18/2011																	
5. SCOTT	1048	6:53 AM 06/18/2011																	

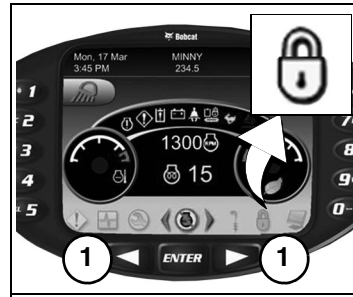
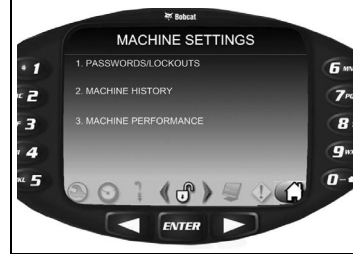

Machine History - User Job Statistics

	<p>Press a scroll button (Item 1) repeatedly until the Security screen icon (Inset) is highlighted.</p>
	<p>MACHINE SETTINGS is visible on screen.</p> <p>Select [2. MACHINE HISTORY].</p>
	<p>Select [2. USER JOB STATISTICS].</p>
	<p>View Job Statistics (Job Hours / Idle Time.</p> <p>Information can be viewed and reset back to zero.</p>





CONTROL PANEL SETUP (CONT'D)

Panel Setup (Deluxe Instrument Panel) (Cont'd)

Machine History - Overall Job Statistics

	<p>Press a scroll button (Item 1) repeatedly until the Security screen icon (Inset) is highlighted.</p>
	<p>MACHINE SETTINGS is visible on screen.</p> <p>Select [2. MACHINE HISTORY].</p>
	<p>Select [3. OVERALL JOB STATISTICS].</p>

Attachments

	<p>Press a scroll button (Item 1) repeatedly until the Attachment screen icon (Inset) is highlighted.</p>
	<p>ATTACHMENTS is visible on screen.</p> <p>Press [ENTER].</p>
	<p>Press [4] or [9] repeatedly until the desired Attachment is visible in the display screen.</p>
	<p>Information about the attachment, recommended auxiliary hydraulic flow and tips about attachment operation will be displayed.</p>

PASSWORD SETUP (KEYLESS START PANEL)

Password Description

Master Password:

A permanent, randomly selected password set at the factory that cannot be changed. This password is used for service by the Bobcat dealer if the owner password is not known or to change the owner password.

Owner Password:

Allows for full use of the excavator. Must be used to change the owner password, or User 1 / User 2 password.

User 1 and User 2 Passwords:

By default, User 1 and User 2 Passwords are not set.

NOTE: The User 1 and User 2 Password cannot be used to change a password or to switch between the Locked / Unlocked modes.

Changing The Owner, User 1, And User 2 Passwords

Figure 252

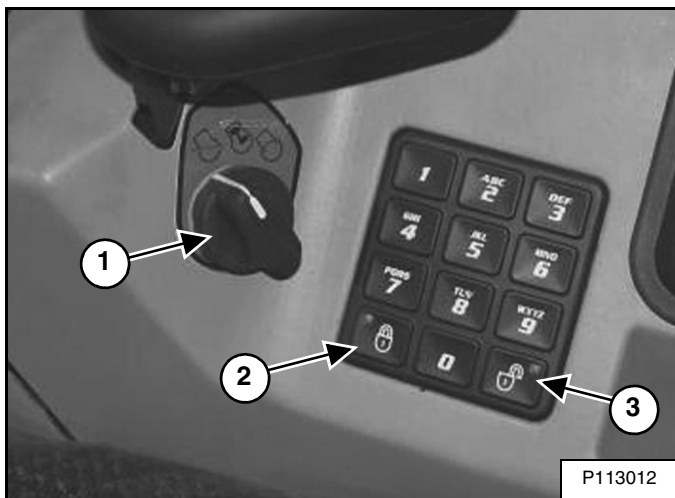

Turn the start switch (Item 1) [Figure 252] to the ON position to turn on the excavator's electrical system.

Enter the five-digit owner password using the keypad if locked.

Press and hold the lock (Item 2) and unlock (Item 3) [Figure 252] keys for three seconds.

The lock key red light or the unlock key green light will flash and the instrument panel display screen will show [CODE].

Enter the five-digit owner or master password using the keypad if locked.

The display screen will show [OWNER] for two seconds. Press the unlock key (Item 3) [Figure 252] to navigate between [OWNER], [USER 1] and [USER 2].

After two seconds, the display screen will show [ENTER].

NOTE: The lock key (Item 2) red light and the unlock key (Item 3) [Figure 252] green light will flash during the procedure.

Enter a new five-digit owner, User 1, or User 2 password using the keypad. An asterisk will show in the display screen for each key pressed.

The display screen will show [AGAIN].

Enter the new five-digit password again.

The display screen will show [STORE] if the password has been changed.

The display screen will show [ERROR] if:

- The second five-digit password is different from the first one entered.
- or
- No number key was pressed for more than 20 seconds.
- or
- "00000" was entered as owner, user 1 or user 2 password.

NOTE: "00000" is not an acceptable owner, user 1 or user 2 password.

The system returns to its previous state. Either the lock key (Item 2) red light or the unlock key (Item 3) [Figure 252] green light will become solid.

PASSWORD SETUP (KEYLESS START PANEL) (CONT'D)

Password Lockout Feature

This feature allows the owner to unlock the password feature so that a password does not need to be used every time the engine is started.

NOTE: The password lockout feature does not function with the User 1 or User 2 passwords.

Turn the start switch (Item 1) [Figure 253] to the ON position to turn on the excavator's electrical system.

Enter the five-digit owner password using the keypad.

Figure 253

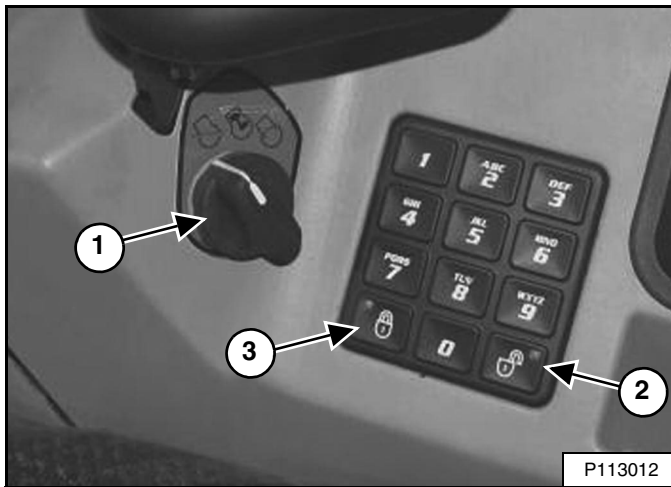

Press the unlock key (Item 2) [Figure 253].

The left panel display screen will show [CODE].

Enter the five-digit owner password using the keypad. The unlock key green light will flash, then become solid.

The excavator can now be started without using a password.

NOTE: Use the following procedure to reset the machine lock so that the excavator requires a password to start the engine.

Turn the key switch to the ON position to turn on the excavator's electrical system.

Press the lock key (Item 3) [Figure 253].

The lock key red light will flash and the left panel display screen will show [CODE].

Enter the five-digit owner password using the keypad. The unlock key green light will flash, then the lock key red light will become solid.

You must now enter the password every time to start the excavator.

PASSWORD SETUP (DELUXE INSTRUMENT PANEL)

Password Setup is available on machines with a Deluxe Instrument Panel.

Password Description

All new machines with a Deluxe Instrument Panel arrive at Bobcat dealerships with the keypad in locked mode. Locked mode means that a password must be used to start the engine.

For security purposes, your dealer may change the password and set the keypad in the locked mode. Your dealer will provide you with the password.

Master Password:

A permanent, randomly selected password set at the factory that cannot be changed. This password is used for service by the Bobcat dealer if the owner password is not known or to change the owner password.

Owner Password:







Allows for full use of the excavator and to set up the Deluxe Instrument Panel. There is only one owner password. The owner password must be used to change the owner or user passwords. Owner should change the password as soon as possible for security of the excavator.

User Password:

Allows starting and operating the excavator; cannot change password or any of the other setup features.

For the procedures to change passwords: (See Changing The Owner Password on Page 166.) and (See Changing The User Passwords on Page 167.)

Changing The Owner Password

	<p>Press a scroll button (Item 1) repeatedly until the Security screen icon (Inset) is highlighted.</p>
	<p>Select [1. PASSWORDS / LOCKOUTS].</p>
	<p>Enter owner password and press [ENTER].</p>
	<p>Select [1. USER SETTINGS].</p>
	<p>Select [1. OWNER].</p>
	<p>Select [2. CHANGE PASSWORD].</p>
	<p>Enter new owner password and press [ENTER].</p> <p>You will be prompted to reenter the new owner password.</p>

PASSWORD SETUP (DELUXE INSTRUMENT PANEL) (CONT'D)

Changing The User Passwords

	<p>Press a scroll button (Item 1) repeatedly until the Security screen icon (Inset) is highlighted.</p>																														
	<p>Select [1. PASSWORDS / LOCKOUTS].</p>																														
	<p>Enter owner password and press [ENTER].</p>																														
	<p>Select [1. USER SETTINGS].</p>																														
<table border="1"> <thead> <tr> <th>NAME</th> <th>PASSWORD</th> <th>JOB CLOCK</th> </tr> </thead> <tbody> <tr> <td>1. SPRINGER</td> <td>OWNER</td> <td>2.3</td> </tr> <tr> <td>2. TONY</td> <td>0123456789</td> <td>9999.9</td> </tr> <tr> <td>3. BRADY</td> <td>22222</td> <td>123.3</td> </tr> <tr> <td>4. BART</td> <td>456789</td> <td>0.5</td> </tr> <tr> <td>5. AL</td> <td>33333</td> <td>452.5</td> </tr> <tr> <td>6. DEAN</td> <td>12345</td> <td>785.2</td> </tr> <tr> <td>7. MICHAEL</td> <td>55555</td> <td>129.2</td> </tr> <tr> <td>8. JOHN</td> <td>54321</td> <td>0.0</td> </tr> <tr> <td>9. EMPTY</td> <td></td> <td>0.0</td> </tr> </tbody> </table>	NAME	PASSWORD	JOB CLOCK	1. SPRINGER	OWNER	2.3	2. TONY	0123456789	9999.9	3. BRADY	22222	123.3	4. BART	456789	0.5	5. AL	33333	452.5	6. DEAN	12345	785.2	7. MICHAEL	55555	129.2	8. JOHN	54321	0.0	9. EMPTY		0.0	<p>Select user.</p>
NAME	PASSWORD	JOB CLOCK																													
1. SPRINGER	OWNER	2.3																													
2. TONY	0123456789	9999.9																													
3. BRADY	22222	123.3																													
4. BART	456789	0.5																													
5. AL	33333	452.5																													
6. DEAN	12345	785.2																													
7. MICHAEL	55555	129.2																													
8. JOHN	54321	0.0																													
9. EMPTY		0.0																													
	<p>Select [2. CHANGE PASSWORD].</p>																														
	<p>Enter new user password and press [ENTER].</p>																														

Password Lockout Feature

This feature allows the owner to unlock the password feature so that a password does not need to be used every time the engine is started.

	<p>Press a scroll button (Item 1) repeatedly until the Security screen icon (Inset) is highlighted.</p>
	<p>Select [1. PASSWORDS / LOCKOUTS].</p>
	<p>Enter owner password and press [ENTER].</p>
	<p>Select [2. MACHINE LOCK].</p>

NOTE: The procedure above can be followed to reset the machine lock so that the machine requires a password to start the engine.

NOTE: When the password is in UNLOCKED, no password is needed. The start switch is used to start the machine.

MAINTENANCE CLOCK

Description

The Maintenance Clock alerts the operator when the next service interval is due. *EXAMPLE:* The maintenance clock can be set to a 500 hour interval as a reminder for the next 500 hour planned maintenance.

Standard Instrument Panel

Figure 254

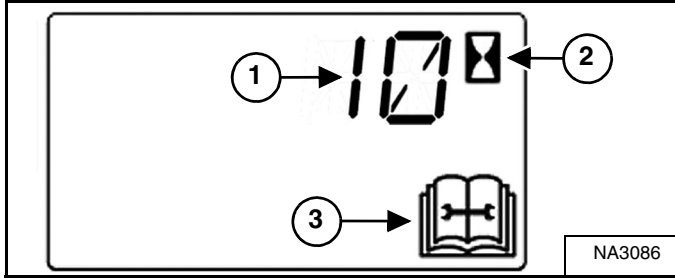

During machine operation, a 2 beep alarm will sound when there are less than 10 hours until the next planned maintenance.

The remaining hours before maintenance is required (Item 1) will appear in the data display for 5 seconds while the service icon (Item 3) and the hourmeter icon (Item 2) [Figure 254] flash.

NOTE: The display will show negative numbers after counting down to zero.

The display will revert to the previous display and will appear for 5 seconds every time the machine is started until the maintenance clock is reset.

Setup

See your Bobcat dealer about installation of this feature.

Reset

Figure 255



Press the Information button (Item 2) [Figure 255] until the display screen shows the maintenance clock.

Press and hold the Information button (Item 2) for 7 seconds until [RESET] (Item 1) [Figure 255] appears in the display screen.

Deluxe Instrument Panel

Figure 256

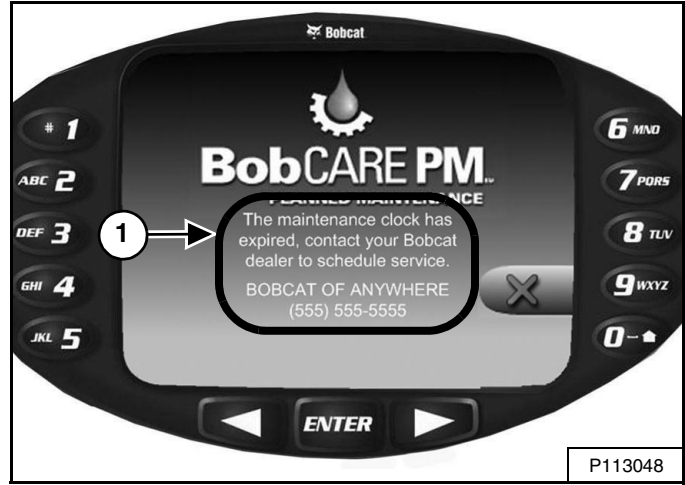

The Deluxe Instrument Panel (if equipped) will display a message (Item 1) [Figure 256] alerting the operator to service the machine.

This message will remain for 10 seconds and will appear for 10 seconds every time the machine is started until the maintenance clock is reset.

Figure 257



The Deluxe Instrument Panel (if equipped) will display a bar (Item 1) [Figure 257] showing the time remaining until next service. This bar will turn red when service is past due. NEXT MAINTENANCE DUE will change to MAINTENANCE PAST DUE and display the number of hours past due.

Keys [4] and [9] can be used to adjust the service interval when the owner is logged in [Figure 257].

SPECIFICATIONS

EXCAVATOR SPECIFICATIONS	170
Machine Dimensions	170
Rated Lift Capacity - Canopy With Heavy Counterweight	172
Rated Lift Capacity - Cab With Heavy Counterweight	173
Performance	174
Controls	174
Engine	175
Hydraulic System	176
Hydraulic Cylinders	176
Hydraulic Cycle Times	177
Electrical	177
Drive System	177
Slew System	177
Undercarriage	178
Capacities	178
Tracks	178
Temperature Range	178

Certain specification(s) are based on engineering calculations and are not actual measurements. Specification(s) are provided for comparison purposes only and are subject to change without notice. Specification(s) for your individual Bobcat equipment will vary based on normal variations in design, manufacturing, operating conditions, and other factors.

EXCAVATOR SPECIFICATIONS

Machine Dimensions

- Where applicable, specifications conform to SAE or ISO standards and are subject to change without notice.

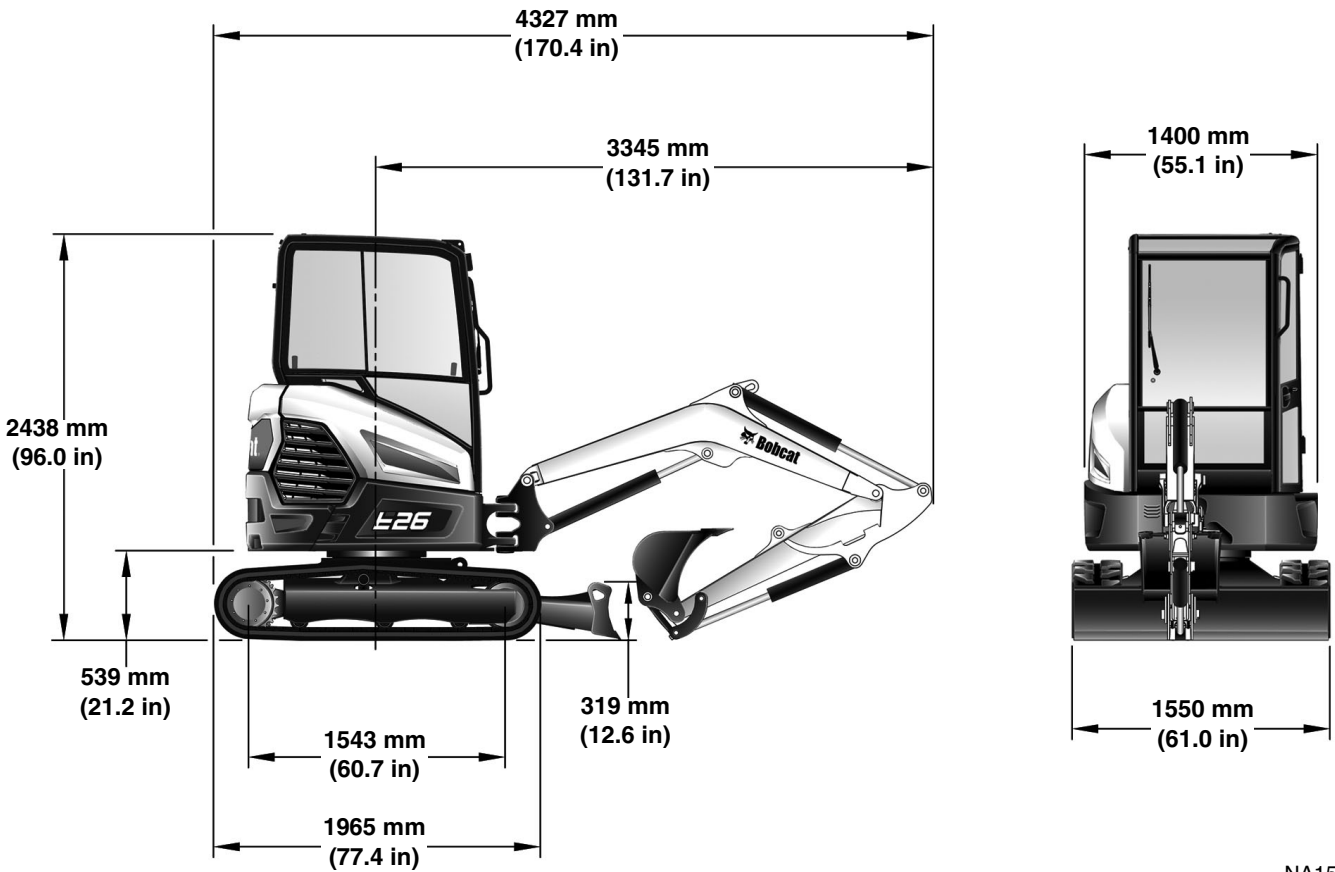
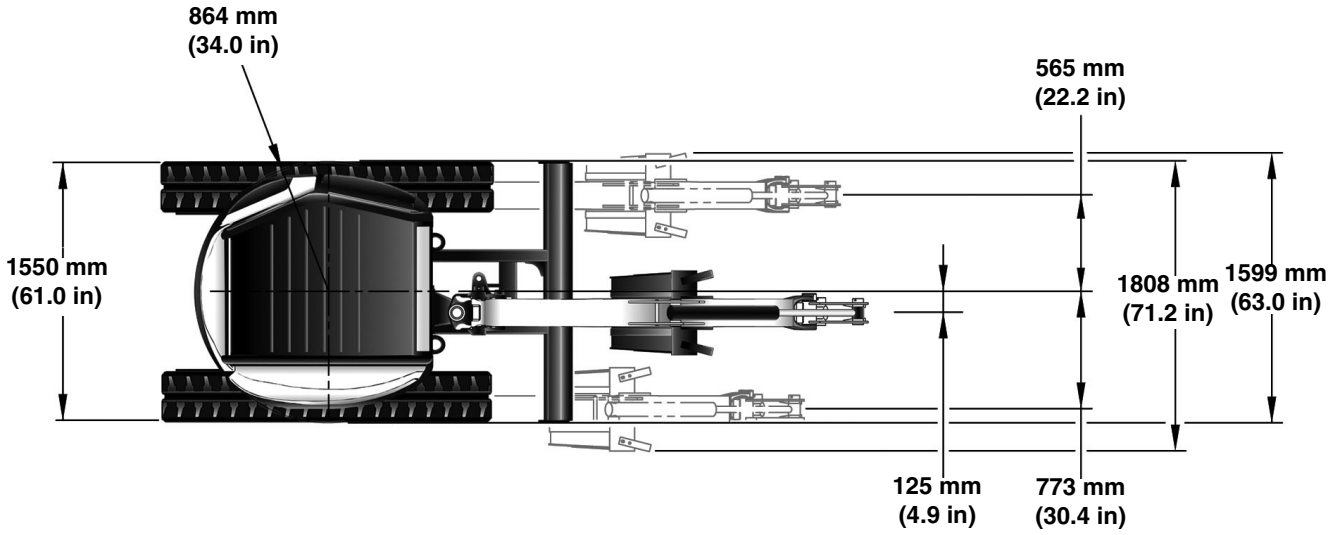

NA15020b

EXCAVATOR SPECIFICATIONS (CONT'D)

Machine Dimensions (Cont'd)

- Where applicable, specifications conform to SAE or ISO standards and are subject to change without notice.

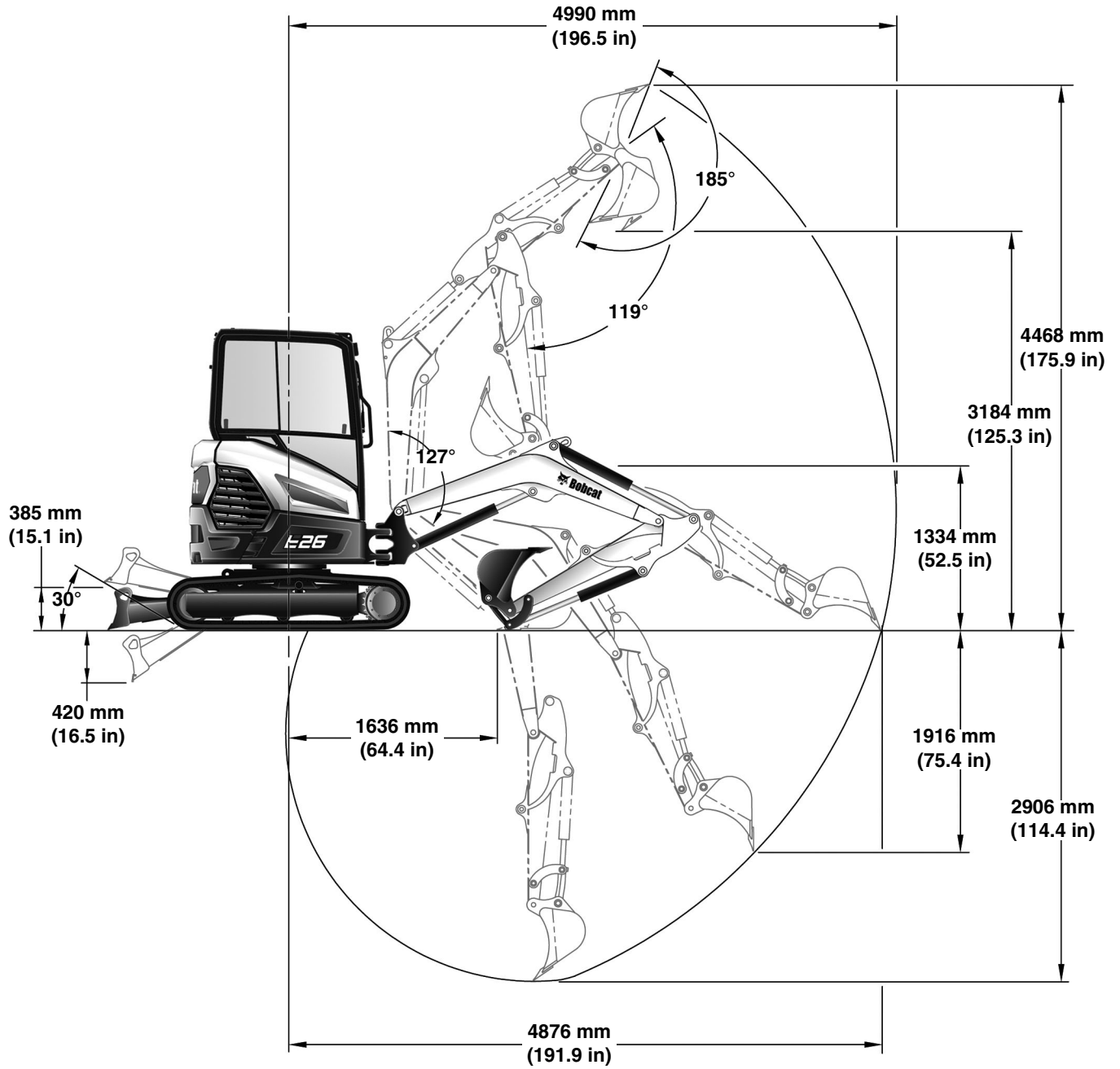

NA15019b

EXCAVATOR SPECIFICATIONS (CONT'D)

Rated Lift Capacity - Canopy With Heavy Counterweight

- Where applicable, specifications conform to SAE or ISO standards and are subject to change without notice.

A		B		B		B		B		B		B	
		2000 mm [79 in]	3000 mm [118 in]	4000 mm [157 in]	kg (lb) @ max. B	2000 mm [79 in]	3000 mm [118 in]	4000 mm [157 in]	kg (lb) @ max. B	2000 mm [79 in]	3000 mm [118 in]	4000 mm [157 in]	kg (lb) @ max. B
3000 mm [118 in]					*565 kg (1246 lb) @ 3630 mm (143 in)			434 kg (957 lb) @ 3630 mm (143 in)				376 kg (829 lb) @ 3630 mm (143 in)	
2000 mm [79 in]		*570 kg [1257 lb]	*602 kg [1327 lb]	*673 kg [1484 lb]	*609 kg (1343 lb) @ 4070 mm (160 in)			358 kg (789 lb) @ 4070 mm (160 in)		500 kg [1102 lb]	322 kg [710 lb]	306 kg (675 lb) @ 4070 mm (160 in)	
1000 mm [39 in]					*662 kg (1459 lb) @ 4270 mm (168 in)			335 kg (739 lb) @ 4270 mm (168 in)		482 kg [1063 lb]	312 kg [688 lb]	281 kg (619 lb) @ 4270 mm (168 in)	
Ground		*1070 kg [2359 lb]	*750 kg [1653 lb]		*709 kg (1563 lb) @ 4150 mm (163 in)			349 kg (769 lb) @ 4150 mm (163 in)		461 kg [1016 lb]	311 kg [686 lb]	292 kg (644 lb) @ 4150 mm (163 in)	
-1000 mm [-39 in]		*1090 kg [2403 lb]			*791 kg (1744 lb) @ 3600 mm (142 in)			428 kg (944 lb) @ 3600 mm (142 in)		462 kg [1019 lb]		358 kg (789 lb) @ 3600 mm (142 in)	
-2000 mm [-79 in]		*1202 kg [2650 lb]			*825 kg (1819 lb) @ 2550 mm (100 in)			*825 kg (1819 lb) @ 2550 mm (100 in)		1002 kg [2209 lb]		638 kg (1407 lb) @ 2550 mm (100 in)	



* → ↯ ↲

SW 19

7359300A

EXCAVATOR SPECIFICATIONS (CONT'D)

Rated Lift Capacity - Cab With Heavy Counterweight

- Where applicable, specifications conform to SAE or ISO standards and are subject to change without notice.

A		B		B		B		B		B		kg (lb) @ max. B					
		2000 mm [79 in]	3000 mm [118 in]	4000 mm [157 in]	2000 mm [79 in]	3000 mm [118 in]	4000 mm [157 in]	2000 mm [79 in]	3000 mm [118 in]	4000 mm [157 in]	2000 mm [79 in]		3000 mm [118 in]	4000 mm [157 in]			
3000 mm [118 in]	*565 kg (1246 lb) @ 3630 mm (143 in)	*570 kg (1257 lb)	*602 kg (1327 lb)	*673 kg (1484 lb)	*750 kg (1653 lb)	*791 kg (1744 lb) @ 3600 mm (142 in)	434 kg (957 lb) @ 3630 mm (143 in)	335 kg (739 lb) @ 4270 mm (168 in)	349 kg (769 lb) @ 4150 mm (163 in)	428 kg (944 lb) @ 3600 mm (142 in)	*825 kg (1819 lb) @ 2550 mm (100 in)	376 kg (829 lb) @ 3630 mm (143 in)	306 kg (675 lb) @ 4070 mm (160 in)	281 kg (619 lb) @ 4270 mm (168 in)	292 kg (644 lb) @ 4150 mm (163 in)	358 kg (789 lb) @ 3600 mm (142 in)	638 kg (1407 lb) @ 2550 mm (100 in)
2000 mm [79 in]	*609 kg (1343 lb) @ 4070 mm (160 in)	*570 kg (1257 lb)	*602 kg (1327 lb)	*673 kg (1484 lb)	*750 kg (1653 lb)	*791 kg (1744 lb) @ 3600 mm (142 in)	358 kg (789 lb) @ 4070 mm (160 in)	335 kg (739 lb) @ 4270 mm (168 in)	349 kg (769 lb) @ 4150 mm (163 in)	428 kg (944 lb) @ 3600 mm (142 in)	*825 kg (1819 lb) @ 2550 mm (100 in)	306 kg (675 lb) @ 4070 mm (160 in)	500 kg (1102 lb)	482 kg (1063 lb)	461 kg (1016 lb)	358 kg (789 lb) @ 3600 mm (142 in)	638 kg (1407 lb) @ 2550 mm (100 in)
1000 mm [39 in]	*662 kg (1459 lb) @ 4270 mm (168 in)	*854 kg (1883 lb)	*1070 kg (2359 lb)	*1193 kg (2635 lb)	*1314 kg (2898 lb)	*1435 kg (3165 lb) @ 3600 mm (142 in)	335 kg (739 lb) @ 4270 mm (168 in)	335 kg (739 lb) @ 4270 mm (168 in)	349 kg (769 lb) @ 4150 mm (163 in)	428 kg (944 lb) @ 3600 mm (142 in)	*825 kg (1819 lb) @ 2550 mm (100 in)	281 kg (619 lb) @ 4270 mm (168 in)	312 kg (688 lb)	312 kg (688 lb)	311 kg (686 lb)	358 kg (789 lb) @ 3600 mm (142 in)	638 kg (1407 lb) @ 2550 mm (100 in)
Ground	*709 kg (1563 lb) @ 4150 mm (163 in)	*1070 kg (2359 lb)	*1070 kg (2359 lb)	*1193 kg (2635 lb)	*1314 kg (2898 lb)	*1435 kg (3165 lb) @ 3600 mm (142 in)	349 kg (769 lb) @ 4150 mm (163 in)	349 kg (769 lb) @ 4150 mm (163 in)	349 kg (769 lb) @ 4150 mm (163 in)	428 kg (944 lb) @ 3600 mm (142 in)	*825 kg (1819 lb) @ 2550 mm (100 in)	292 kg (644 lb) @ 4150 mm (163 in)	461 kg (1016 lb)	461 kg (1016 lb)	461 kg (1016 lb)	358 kg (789 lb) @ 3600 mm (142 in)	638 kg (1407 lb) @ 2550 mm (100 in)
-1000 mm [-39 in]	*791 kg (1744 lb) @ 3600 mm (142 in)	*1090 kg (2403 lb)	*1090 kg (2403 lb)	*1193 kg (2635 lb)	*1314 kg (2898 lb)	*1435 kg (3165 lb) @ 3600 mm (142 in)	428 kg (944 lb) @ 3600 mm (142 in)	428 kg (944 lb) @ 3600 mm (142 in)	428 kg (944 lb) @ 3600 mm (142 in)	428 kg (944 lb) @ 3600 mm (142 in)	*825 kg (1819 lb) @ 2550 mm (100 in)	358 kg (789 lb) @ 3600 mm (142 in)	462 kg (1019 lb)	462 kg (1019 lb)	462 kg (1019 lb)	358 kg (789 lb) @ 3600 mm (142 in)	638 kg (1407 lb) @ 2550 mm (100 in)
-2000 mm [-79 in]	*825 kg (1819 lb) @ 2550 mm (100 in)	*1202 kg (2650 lb)	*1202 kg (2650 lb)	*1193 kg (2635 lb)	*1314 kg (2898 lb)	*1435 kg (3165 lb) @ 3600 mm (142 in)	*825 kg (1819 lb) @ 2550 mm (100 in)	*825 kg (1819 lb) @ 2550 mm (100 in)	*825 kg (1819 lb) @ 2550 mm (100 in)	*825 kg (1819 lb) @ 2550 mm (100 in)	*825 kg (1819 lb) @ 2550 mm (100 in)	1002 kg [2209 lb]	1002 kg [2209 lb]	1002 kg [2209 lb]	1002 kg [2209 lb]	638 kg (1407 lb) @ 2550 mm (100 in)	638 kg (1407 lb) @ 2550 mm (100 in)

SW 19 7359301A

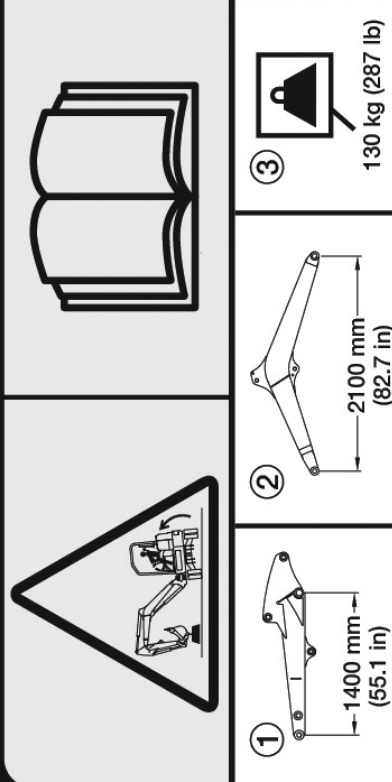
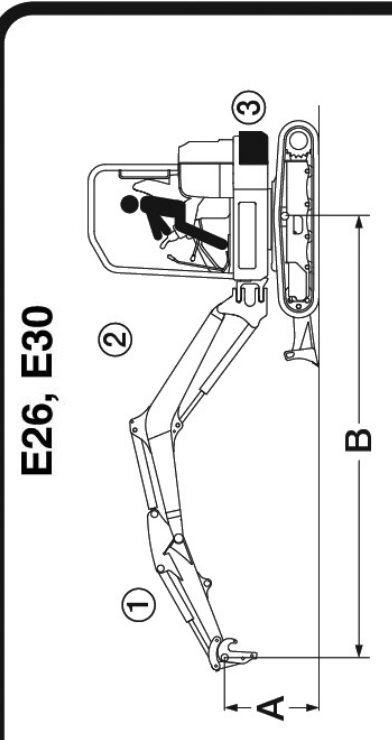

EXCAVATOR SPECIFICATIONS (CONT'D)

Performance

Operating weight (canopy, long arm, standard seat, heavy and add-on counterweight, rubber track, standard bucket, and 75 kg operator):	2942 kg (6489 lb)
If equipped with the following:	Cab with HVAC, add 137 kg (302 lb) Cab with Heater, add 118 kg (260 lb) Cloth or Vinyl Suspension Seat, add 8 kg (18 lb) Steel Tracks, add 119 kg (262 lb)
Travel Speed (Low / High)	2,9 km/h / 5,2 km/h (1.8 mph / 3.2 mph)
Digging Force (per ISO 6015) (with long arm)	Arm - 15780 N (3547 lbf) Bucket - 25140 N (5652 lbf)

Controls

Steering	Two hand levers (optional foot pedals)
Hydraulics	Two hand-operated joysticks control boom, bucket, arm and upperstructure slew Thumb switch controls auxiliary hydraulics and boom swing
Blade	Hand lever
Two Speed	Switch on blade lever
Boom Swing	Electric switches on joysticks
Auxiliary Hydraulics	Electric switches on joysticks
Auxiliary Pressure Release	Electric switch in right joystick
Engine	Engine speed control dial with auto idle feature, key or keyless start switch
Starting Aid	Glow Plugs - activated by start switch
Brakes	
Travel	
Service and Parking	Hydraulic lock in motor circuit
Slew	
Service	Hydraulic lock on motor
Holding	Spring applied - hydraulic release

EXCAVATOR SPECIFICATIONS (CONT'D)

Engine

Make / Model	Kubota® D1305-E4B-BCZ-1A Tier 4
Fuel / Cooling	Diesel / Liquid
Horsepower: – Gross power (ISO 14396) – Gross power (SAE J1995)	18,2 kW (24.4 hp) @ 2400 rpm 18,5 kW (24.8 hp) @ 2400 rpm
Torque: – Gross torque (ISO 14396) – Gross torque (SAE J1995)	80,1 N•m (59.1 lb-ft) @ 1600 rpm 81,3 N•m (60.0 lb-ft) @ 1600 rpm
Number Of Cylinders	3
Displacement	1,261 L (77.0 in ³)
Bore / Stroke	78 x 88 mm (3.07 x 3.46 in)
Lubrication	Pressure System with Filter
Crankcase Ventilation	Closed breathing
Air Cleaner	Dual dry replacement paper cartridge with safety element
Ignition	Diesel - Compression
Low Idle Speed	1100 - 1250 rpm
High Idle Speed	2450 - 2550 rpm
Engine Coolant	(See Coolant Types on Page 127.) and (See Coolant Concentration on Page 128.)

EXCAVATOR SPECIFICATIONS (CONT'D)

Hydraulic System

Pump Type	Engine driven, dual outlet, variable displacement, load sensing, torque limited, piston pump with gear pumps
Pump Capacity Piston Pump Gear Pump - 1 Gear Pump - 2	2 x 33,75 L/min (2 x 8.9 U.S. gpm) 20 L/min (5.3 U.S. gpm) 6,75 L/min (1.8 U.S. gpm)
Auxiliary Flow	53,75 L/min (14.2 U.S. gpm)
Hydraulic Filter	Full flow replaceable, 3 micron synthetic media element
Control Valve	10 spool, parallel series type, open center
Fluid Type	Bobcat Fluid, Hydraulic / Hydrostatic 6903117 - (2.5 U.S. gal) 6903118 - (5 U.S. gal) 6903119 - (55 U.S. gal)
System Relief Pressure Slew relief pressure Blade, Boom Swing Boom, Arm, Bucket, Travel (and Auxiliary 3 if equipped) Joystick Control Pressure	20600 kPa (206 bar) (2988 psi) 20600 kPa (206 bar) (2988 psi) 24000 kPa (240 bar) (3481 psi) 3200 kPa (32 bar) (464 psi)
Auxiliary Relief (1 and 2 if equipped)	18000 kPa (180 bar) (2611 psi)
Arm Port Relief Base And Rod End	29000 kPa (290 bar) (4206 psi)
Boom Port Relief Base And Rod End	29000 kPa (290 bar) (4206 psi)
Bucket Port Relief Base And Rod End	26000 kPa (260 bar) (3771 psi)
Blade Port Relief Base And Rod End	27000 kPa (270 bar) (3916 psi)
Main Hydraulic Filter Bypass	340 kPa (3,4 bar) (49 psi)
Case Drain	120 kPa – 160 kPa (1,2 – 1,6 bar) (17 – 23 psi)

Hydraulic Cylinders

Cylinder	Bore	Rod	Stroke
Boom (cushion up)	76,2 mm (3.00 in)	44,5 mm (1.75 in)	546 mm (21.5 in)
Arm (cushion retract / extend)	76,2 mm (3.00 in)	44,5 mm (1.75 in)	492 mm (19.4 in)
Bucket	60,5 mm (2.38 in)	38,1 mm (1.50 in)	445 mm (17.5 in)
Boom Swing	69,8 mm (2.75 in)	38,1 mm (1.50 in)	429 mm (16.9 in)
Blade	82,6 mm (3.25 in)	44,5 mm (1.75 in)	170 mm (6.7 in)

EXCAVATOR SPECIFICATIONS (CONT'D)

Hydraulic Cycle Times

Bucket Curl	2,4 seconds
Bucket Dump	1,6 seconds
Arm Retract	2,7 seconds
Arm Extend	2,2 seconds
Boom Raise	4,1 seconds
Boom Lower	5,1 seconds
Boom Swing Left (60°)	4,1 seconds
Boom Swing Right (60°)	5,6 seconds
Blade Raise	2,4 seconds
Blade Lower	3,1 seconds

Electrical

Starting Aid	Glow Plugs
Alternator	12 volt, 65 Amp open frame w/ internal regulator
Battery	12 volt - 500 CCA @ -18°C (0°F)
Starter	12 volt; gear reduction 2,0 kW (2.7 hp)
Instrumentation	Fuel gauge, audible alarm, visual warning for engine functions and hourmeter
Lights	20 watt (LED)

Drive System

Final Drive	Each track is driven by hydrostatic axial piston motor
Drive Reduction	41,9:1 two stage planetary
Gradeability	30°
Brakes	Hydraulic lock on motor

Slew System

Slew Drive	Gear pump connected to a planetary drive
Slew Circle	Single row shear type ball bearings with internal gear
Gear Reduction	159,5:1 (total), 21,5:1 (slew motor), 7,4:1 (slew bearing)
Brake	Spring applied, pressure released
Slew Speed	9,3 rpm

EXCAVATOR SPECIFICATIONS (CONT'D)

Undercarriage

Crawler Track Design	Sealed track rollers with boxed section track roller frame, grease type track adjuster with shock absorbing recoil spring
Width of crawler	1550 mm (61.0 in)

Capacities

Fuel Tank	34,4 L (9.1 U.S. gal)
Hydraulic Reservoir Only (center of Sight Glass)	Tank Cap. 10,2 L (2.7 U.S. gal)
Hydraulic System (with Reservoir)	23 L (6.1 U.S. gal)
Cooling System with / without Heater	4,8 L (1.3 U.S. gal) / 4,4 L (1.2 U.S. gal)
Engine Oil and Filter	4,0 L (4 U.S. qt)
Final Drive (each)	0,6 L (0.63 U.S. qt)
Air Conditioning Refrigerant (R134a)	0,77 kg (1.7 lb)

Tracks

Type	Rubber
Width	300 mm (11.8 in)
Number Of Shoes	Single Assembly
Number of Track Rollers (per side)	3
Ground Pressure	28,4 kPa (4.13 psi)

Temperature Range

Operation and storage	-17° – +43°C (-1.3° – +109.4°F)
-----------------------	---------------------------------

WARRANTY

WARRANTY	180
Machine Warranty	180
Engine Emission Warranty	180

WARRANTY

Machine Warranty

A statement explaining the terms and conditions of the warranty coverage that applies to your machine was provided in the literature package shipped with the machine. If this warranty statement is lost or damaged, contact your dealer or visit Bobcat.com to obtain a new copy.

Engine Emission Warranty









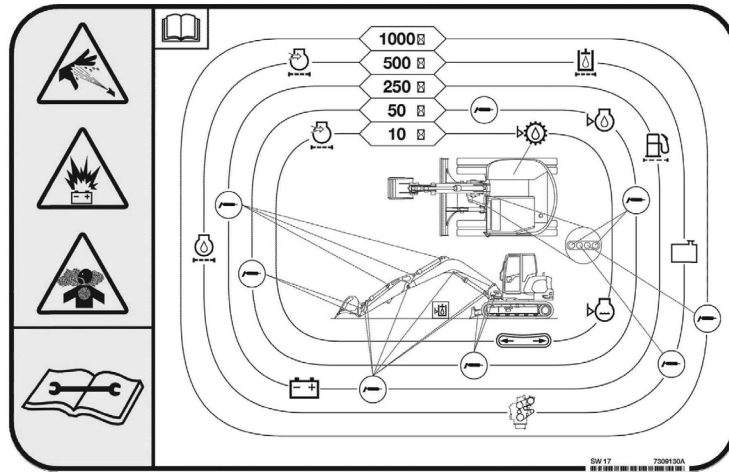









A statement explaining the terms and conditions of the Engine Manufacturer's emission warranty coverage was provided in the literature package shipped with the machine. If this emission warranty statement is lost or damaged, contact your dealer or visit Bobcat.com to obtain a new copy.

ALPHABETICAL INDEX

AIR CLEANER SERVICE	119	OPERATOR CAB (ROPS / TOPS / FOPS)	41
ALTERNATOR AND FAN BELT	145	OPERATOR CANOPY (ROPS / TOPS / FOPS)	41
ARM LOAD HOLDING VALVE	65	OPERATOR SAFETY WARNING	1
ATTACHMENTS	77	OVERLOAD WARNING DEVICE	61
BLADE CONTROL LEVER	61	PASSWORD SETUP (DELUXE INSTRUMENT PANEL)	166
BOBCAT COMPANY IS ISO 9001 CERTIFIED	3	PASSWORD SETUP (KEYLESS START PANEL)	164
BOOM LOAD HOLDING VALVE	63	PIVOT PINS	150
BOOM SWING	62	PRE-STARTING PROCEDURE	69
BUCKET	147	PUBLICATIONS AND TRAINING RESOURCES	13
CAB FILTERS	117	REGULAR MAINTENANCE ITEMS	3
CONTROL CONSOLE LOCKOUTS	110	RIGHT SIDE COVER	115
CONTROL PANEL SETUP	158	RIGHT SIDE PANEL	116
DAILY INSPECTION	67	SAFETY INSTRUCTIONS	9
DELIVERY REPORT	4	SEAT BELT	111
DIAGNOSTIC SERVICE CODES	153	SERIAL NUMBER LOCATION	4
ELECTRICAL SYSTEM	131	SERVICE SCHEDULE SYMBOLS	182
EMERGENCY EXIT	46	SERVICE SCHEDULE	108
ENGINE COOLING SYSTEM	127	SPARK ARRESTER MUFFLER	141
ENGINE LUBRICATION SYSTEM	125	STARTING THE ENGINE	71
ENGINE SPEED CONTROL	62	STOPPING THE ENGINE AND LEAVING THE EXCAVATOR	76
EXCAVATOR IDENTIFICATION	5	TAILGATE	114
EXCAVATOR SPECIFICATIONS	170	TOWING THE EXCAVATOR	99
EXCAVATOR STORAGE AND RETURN TO SERVICE	151	TRACK ROLLER AND IDLER LUBRICATION . 148	
FEATURES, ACCESSORIES, AND ATTACHMENTS	6	TRACK TENSION	142
FIRE PREVENTION	11	TRANSPORTING THE EXCAVATOR ON A TRAILER	101
FUEL SYSTEM	121	TRAVEL CONTROLS	48
HEATING AND VENTILATION	118	TRAVEL MOTOR	144
HYDRAULIC CONTROLS	50	WARRANTY	180
HYDRAULIC SYSTEM	138	X-CHANGE	147
INSTRUMENTS AND CONSOLES	25		
INTENDED USE	24		
LIFTING THE EXCAVATOR	100		
MACHINE SIGNS (DECALS)	14		
MAINTENANCE CLOCK	168		
MAINTENANCE SAFETY	107		
MONITORING THE DISPLAY PANELS	75		
MOTION ALARM SYSTEM	112		
MOTION ALARM SYSTEM	47		
OPERATING PROCEDURE	88		

SERVICE SCHEDULE SYMBOLS



 Check Engine Oil	 Check Gear Box and / or Travel Motor Fluid
 Change Engine Oil and Filter	 Change Gear Box and / or Travel Motor Fluid
 Check Engine Coolant	 Check Track Tension, Adjust As Needed
 Change Engine Coolant	 Check Belt Tension, Adjust Or Replace As Needed
 Check Engine Air Filter, Change As Necessary	 Lubricate Grease Fittings
 Drain Contaminants From Fuel Filter	 Seat Belt
 Drain Contaminants From Fuel Tank	 Cab / Canopy
 Change Fuel Filter	 Spark Arrestor Muffler
 Check Hydraulic Fluid	
 Change Hydraulic Fluid and Filter(s)	



WARNING: Cancer and Reproductive Harm. This product can expose you to chemicals including lead and lead compounds, mineral oils, and phthalates which are known to the State of California to cause cancer and birth defects or other reproductive harm. For more information go to www.P65Warnings.ca.gov.



WARNING: Breathing diesel engine exhaust exposes you to chemicals known to the State of California to cause cancer and birth defects or other reproductive harm.

- Always start and operate the engine in a well-ventilated area.
- If in an enclosed area, vent the exhaust to the outside.
- Do not modify or tamper with the exhaust system.
- Do not idle the engine except as necessary.

For more information go to www.P65warnings.ca.gov/diesel.